

K/5 BLAZER

K/5 BLAZER MODEL SELECTOR

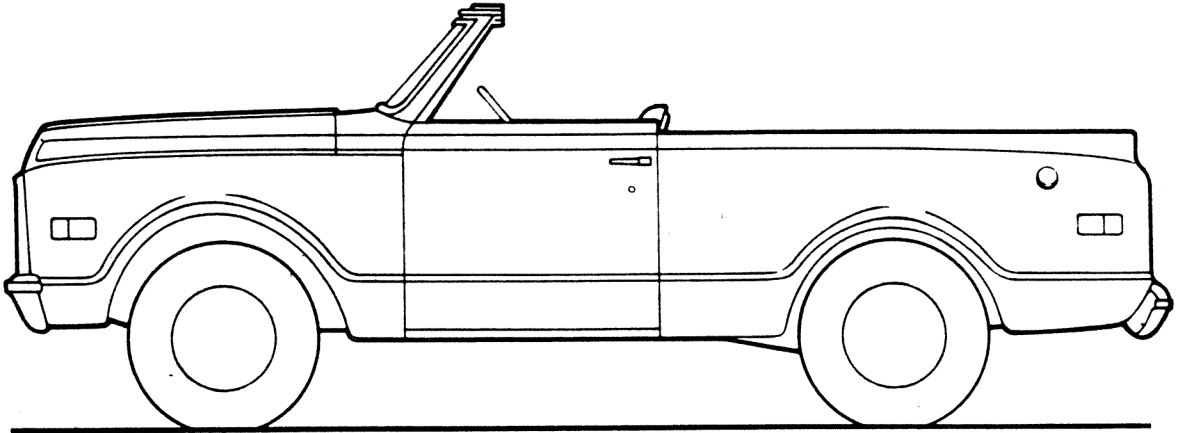

SERIES	ENGINE	MODEL No.
C10	6 cyl.	CS10514
	8 cyl.	CE10514
K10 (4-Wheel-Drive)	6 cyl.	KS10514
	8 cyl.	KE10514

K/5 BLAZER

STANDARD SPECIFICATIONS

(See Blue Tab Section for Specification Details)

Series	C10	K10
Engine		
Base equip—6 cyl.	250-6	250-6
—8 cyl.	307-V8	307-V8
Clutch—6 cyl.	10", 100 sq. in.	10", 100 sq. in.
—8 cyl.	11", 124 sq. in.	11", 124 sq. in.
Air Filter	Oiled-paper element	
Oil Filter	Throw-away type 1-qt.	
Exhaust System	Single; aluminized	
Exhaust Emission Control	*Controlled Combustion System *Light Duty	
Suspension, Front	Independent	Hypoid Driving Axle
Type	Coil Springs	Leaf Springs
Axle Capacity	3100 lb.	3300 lb.
Axle Ratio	—	3.73
Springs @ ground	1450 lb. ea.	1450 lb. ea.
Shock Absorbers	1" dia.	1" dia.
Suspension, Rear	Hypoid Driving Axle	
Type	Coil Springs	Leaf Springs
Axle Capacity	3500 lb.	3500 lb.
Axle Ratio	3.73	3.73
Springs, Main @ ground	1450 lb. ea.	2000 lb. ea.
Shock Absorbers	1" dia.	1" dia.
Brakes	Hydraulic; Self-adjusting	
Front	Disc; 11.86" rotor	Disc; 11.86" rotor
Rear	Drum; 11" x 2"	Drum; 11" x 2"
Booster	Single Diaphragm	
Parking	Cable to Rear Wheels	
Electrical	12 Volt; negative ground	
Battery—6 cyl.	45 amp.	
—8 cyl.	61 amp.	
Delcotron Generator	37 amp.	
Frame	Carbon Steel; 39,000 psi	
Section Modulus	2.98	2.70
Fuel Tank (nominal capacity)	21 gal.	
Steering	Recirculating Ball	
Transmission	Fully-synchronized 3-Speed	
Shift Location	Steering Column	
Transfer Case	—	2-Speed Dana 20
Shift Lever	—	Single Lever
PTO Opening	—	Bottom
Tires	(5) E78-15B (4PR)	
Wheels	(5) Disc 15" x 6.0"	

*California requires Air Injection Reactor system.

K/5 BLAZER

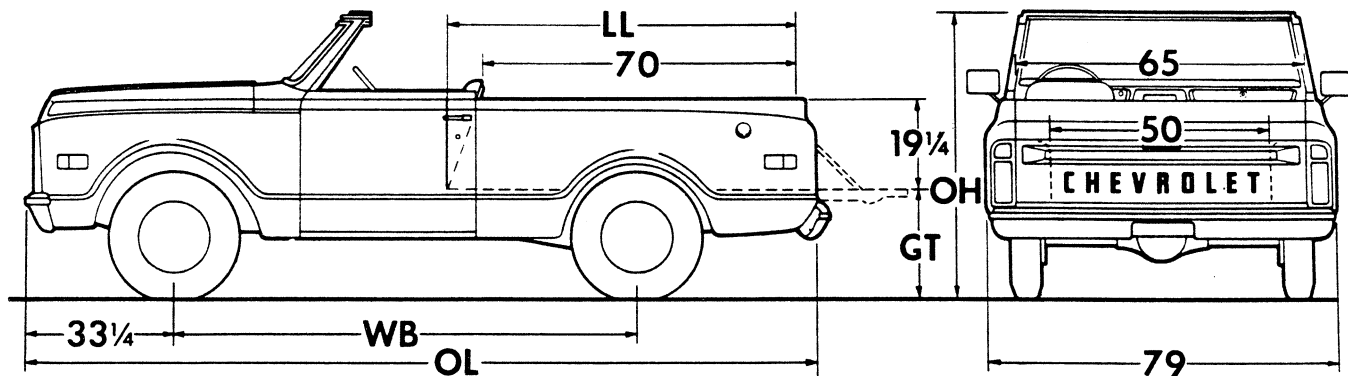

Models	Engine No. Cyl.	→Dimensions (in)★					Curb Weights (lb)			Ground Clearance (In)★	
		WB	LL	OL	OH	GT	Front	Rear	Total	Front	Rear

C10 SERIES

CS10514	6	104	75 1/4	180 1/2	(a)66 1/4	26 1/2	1935	1576	3511	7 1/2	7
CE10514	8						2046	1595	3641		

(a) Dimension 70" with optional top

K10 SERIES

KS10514	6	104	75 1/4	180 1/2	(b)68 1/2	29	2134	1644	3778	7	7
KE10514	8						2252	1661	3913		

(b) Dimension 72" with optional top

★Dimensions with std equipment, unloaded.

→Indicates Change

K/5 BLAZER

POWER TEAMS

ENGINES		TRANSMISSIONS	Transfer Case	REAR AXLES*		
Option Number and Model Application	Description	Type (Standard or Optional)		Type and Capacity	Ratios	
					With Single Rear Wheels	
				Standard	Optional	

C10 SERIES

■ Standard 6-Cylinder on CS10 models	250-cu-in Six	3-Speed Manual (Std)—ZW4	—	Chevrolet 3500	3.73	3.07 or 4.11
		4-Speed (Chevrolet CH465)—M20	—	Chevrolet 3500	3.73	3.07 or 4.11
		Turbo Hydra-matic—M49	—	Chevrolet 3500	3.73	3.07 or 4.11
● Standard 8-Cylinder on CE10 models	307-cu-in V8	3-Speed Manual (Std)—ZW4	—	Chevrolet 3500	3.73	3.07 or 4.11
		4-Speed (Chevrolet CH465)—M20	—	Chevrolet 3500	3.07	3.73 or 4.11
		Turbo Hydra-matic—M49	—	Chevrolet 3500	3.07	3.73 or 4.11
■ Option LS9 on CE10 models	350-cu-in V8	4-Speed (Chevrolet CH465) (Std)—ZW4	—	Chevrolet 3500	3.07	3.73 or 4.11
		Turbo Hydra-matic—M49	—	Chevrolet 3500	3.07	3.73 or 4.11

K10 SERIES

■ Standard 6-Cylinder on KS10 models	250-cu-in Six	3-Speed Manual (Std)—ZW4	Dana #20	Chevrolet 3300	3.73	—
		4-Speed (Chevrolet CH465)—M20	New Process 205	Chevrolet 3300	3.73	—
● Standard 8-Cylinder on KE10 models	307-cu-in V8	Turbo Hydra-matic—M49	New Process 205	Chevrolet 3300	3.73	—
		■ Option LS9 on KE10 models	350-cu-in V8	4-Speed (Chevrolet CH465) M20	New Process 205	Chevrolet 3300
Turbo Hydra-matic—M49	New Process 205			Chevrolet 3300	3.07	3.73

* Positraction rear axle also available.

■ Available for registration in the State of California when California Assembly Line Emission Test (Option YF5) is applied.

● Not available for registration in the State of California.

ENGINE RATINGS

(Engine ratings shown below are S.A.E. net ratings @ 85° F)

	250 Six	307 V8	350 V8
Net Horsepower	110 @ 3800 rpm	135 @ 4000 rpm	175 @ 4000 rpm
Net Torque, lb-ft	185 @ 1600 rpm	230 @ 2400 rpm	290 @ 2400 rpm

K/5 BLAZER

→GVW SELECTOR

GVW Rating (lb)	Minimum Equipment Required for GVW Rating		
	Tires, Front	Tires, Rear	Chassis Equipment

C10 SERIES

4600	E78-15B(4PR) (TL)	E78-15B(4PR) (TL)	Standard
4900	G78-15B(4PR) (TL or TB)	G78-15B(4PR) (TL or TB)	
5400	H78-15B(4PR) (TL)	H78-15B(4PR) (TL)	2000-lb ea rear spring
	7.00-15C(6PR) (TB)	7.00-15C(6PR) (TB)	

K10 SERIES

4600	E78-15B(4PR) (TL)	E78-15B(4PR) (TL)	Standard
5200	G78-15B(4PR) (TL or TB)	G78-15B(4PR) (TL or TB)	
	6.50-16C(6PR) (TB)	6.50-16C(6PR) (TB)	
5850	H78-15B(4PR) (TL)	H78-15B(4PR) (TL)	
	7.00-15C(6PR) (TB) (TT)	7.00-15C(6PR) (TB) (TT)	

TL—Tubeless

TB—Tube Type

TT—Truck Type

K/5 BLAZER

1972 MODELS WITH STANDARD EQUIPMENT

Model Number and Description	Wheel-base	Factory D & H§	List Price	Mfr's Sgt'd Retail Price★	Desti-nation Charge & Group Number	Total
■ 6-Cylinder High Torque 250 Engine						
C10 Series 2-Wheel Drive						
CS10514 Utility	104"	\$12.25	\$2575.00	\$2587.25	17.....
K10 Series 4-Wheel Drive						
KS10514 Utility	104"	12.25	3131.00	3143.25	18.....
♦ 8-Cylinder High Torque 307 Engine						
C10 Series 2-Wheel Drive						
CE10514 Utility	104"	12.25	2690.00	2702.25	17.....
K10 Series 4-Wheel Drive						
KE10514 Utility	104"	12.25	3246.00	3258.25	18.....

★Manufacturer's Suggested Retail Prices do not include state and local taxes, license fees, options or accessories.
 ■Available for registration in the State of California when California Assembly Line Emission Test (Option YF5) is applied.
 ♦Available for registration in the State of California when optional 350 engine is ordered and California Assembly Line Emission Test is applied.

OPTIONS AND ACCESSORIES WHEN INSTALLED BY CHEVROLET

Description	Option Number	Added Weight (F) (R)	Factory D & H§	List Price	Mfr's Suggested Retail Delivered Price◇
-------------	---------------	----------------------	----------------	------------	---

MODEL OPTION

CST: K10 models available only when G78-15/B or larger tires are ordered. Includes vinyl bucket seats; console; RH sunshade and armrest; cigar lighter; nameplates; special insulation; undercoating; chromed bumpers; bright control knob and pedal trim; bright windshield, body side, tailgate, taillight and back-up light moldings; bright fuel filler cap and side marker reflectors. K10 models also include bright transfer case shift levers.

With auxiliary top. Also includes door and body trim panels with bright upper retainers; spare tire cover and front color-keyed carpeting.

HIGHLANDER CLOTH INTERIOR TRIM IS ALSO AVAILABLE. SEE INTERIOR TRIM OPTIONS PLUS INTERIOR AND EXTERIOR COLOR SELECTION CHART FOR AVAILABILITY AND ORDERING INFORMATION.

Without auxiliary top. Available only when door glass is ordered. Also includes front color-keyed vinyl coated rubber floor mat.

.....	Z84	10 15	—	\$355.00	\$355.00
.....	Z84	10 6	—	293.00	293.00

POWER TEAMS AND AXLES

(See Power Teams Chart for availability and complete specifications)

Engine: 350 V8. CE-KE10 models only. Available only when optional transmission is ordered. Available for registration in the State of California. Includes 4-barrel carburetor and 12" coil clutch.

Transmissions:

Turbo Hydra-matic. K10 models available only when G78-15 or larger tires are ordered.

Chevrolet 4-Speed. Available only when G78-15 or larger tires are ordered. CS-KS10 models includes HD clutch

C10 models only

K10 models only

.....	LS9	21 6	—	43.00	43.00
.....	M49	12 5	—	236.00	236.00
.....	M20	(a)	—	103.00	103.00
.....	M20	116 39	—	108.00	108.00

Axles, Rear:

3.07 Ratio. C10 models only

With 3-speed or 4-speed transmission

CS10 models with Turbo Hydra-matic transmission

3.73 Ratio

4.11 Ratio. C10 models only

With 250 or 307 engine

With 350 engine

With 4-speed transmission

With Turbo Hydra-matic transmission without air conditioning. Includes HD cooling

With Turbo Hydra-matic transmission and air conditioning

Positraction

.....	H01	0 0	—	12.00	12.00
.....	H01	0 0	—	18.00	18.00
.....	H05	0 0	—	12.00	12.00
.....	H04	0 0	—	12.00	12.00
.....	H04	9 2	—	12.00	12.00
.....	H04	9 2	—	14.40	14.40
.....	H04	9 2	—	12.00	12.00
.....	G80	0 3	—	64.00	64.00

§ D&H amounts reflect provision for pass through of tire weight tax imposed on manufacturer or importer of tires.

◇ State and local taxes not included.

(a) 6-cylinder models (F) 78 (R) 21; 8-cylinder models (F) 63 (R) 17.

K/5 BLAZER

OPTIONS AND ACCESSORIES WHEN INSTALLED BY CHEVROLET

Description	Option Number	Added Weight (F) (R)		Factory D & H§	List Price	Mfr's Suggested Retail Delivered Price◇
OTHER OPTIONS						
Air Cleaner: Poly-Wrap	K43	0	0	—	\$ 10.00	\$ 10.00
Air Conditioning, All-Weather: V8 models with G78-15 or larger tires only. Includes HD radiator and 61-amp generator.....	C60	87	10	—	410.00	410.00
Batteries: 12-volt						
<i>Auxiliary.</i> 45-amp-hr, 9-plate. K10 models available only when G78-15/B or larger tires are ordered.....	TP2	53	9	—	46.00	46.00
<i>Heavy-Duty.</i> 80-amp-hr, 15-plate.....	T60	(a)		—	16.00	16.00
Bumpers: Chromed. Front and rear. Included when CST is ordered.....	V37	0	0	—	31.00	31.00
California Assembly Line Emission Test: Released to conform with State of California registration requirements. Not available when 307 engine is ordered.....	YF5	0	0	—	15.00	15.00
Caps, Hub: Chromed. Not available when 10.00-16.5/C tires are ordered						
C10 models only.....	P03	0	0	—	10.00	10.00
K10 models only.....	P03	2	2	—	13.00	13.00
Clutch, Heavy-Duty: Diameter 11". Available on CS-KS10 models with standard 3-speed transmission only. Included when Chevrolet 4-speed transmission is ordered.....	M01	2	1	—	6.50	6.50
Cooling: HD radiator only. Included when air conditioning or when combination of 350 engine with Turbo Hydra-matic transmission and 4.11 ratio rear axle is ordered.....	V01	(b)		—	26.00	26.00
Gauges:						
<i>Ammeter, temperature and oil pressure</i>	Z53	1	0	—	12.00	12.00
<i>Tachometer, ammeter, temperature and oil pressure</i>	U16	2	0	—	56.00	56.00
Generators:						
<i>42-amp Delcotron.</i> Not available when air conditioning is ordered.....	K79	1	0	—	23.00	23.00
<i>61-amp Delcotron.</i> Included when air conditioning is ordered.....	K76	1	0	—	31.00	31.00
Glass, Door: Frameless drop glass windows and framed vent window glass. Included when auxiliary top is ordered.						
Without CST.....	A09	N.A.	N.A.	—	41.00	41.00
With CST. Also included chromed vent window moldings..	A09	N.A.	N.A.	—	51.00	51.00
Glass, Soft-Ray: <i>All windows.</i> Available only when auxiliary top or door glass is ordered.						
With door glass only.....	A11	0	0	—	18.00	18.00
With auxiliary top only.....	A11	0	0	—	30.00	30.00
Guards, Door Edge	B93	0	0	—	6.00	6.00
Hubs, Front Free-Wheeling: K10 models only. Manual control at hubs.....	F76	9	0	—	75.00	75.00
Lighter, Cigar: Included when CST is ordered.....	U37	0	0	—	5.00	5.00
Mirrors, Exterior: Camper type. Driver and passenger <i>Stainless Steel</i>	DF2	7	2	—	50.00	50.00
Moldings, Custom: Included when CST is ordered. Includes bright metal lower fender, door and body side moldings; tail-light and back-up light moldings plus bright fuel filler cap..	BX2	2	4	—	46.00	46.00
Paint, Exterior: Solid color. See Color and Trim Chart....	...	0	0	—	N.C.	N.C.
Plate, Fuel Tank Skid: K10 models only.....	NA4	37	25	—	51.00	51.00
Plate: Serial Number (State of Pennsylvania) "K" Plate. Available only when H78-15, L78-15 or 7.00-15 tires and HD rear springs are ordered.....	Z55	0	0	—	N.C.	N.C.

§ D&H amounts reflect provision for pass through of tire weight tax imposed on manufacturer or importer of tires.

◇ State and local taxes not included.

(a) 6-cylinder models (F) 14 (R) -2; 8-cylinder models (F) 2 (R) 0.

(b) 6-cylinder models (F) 4 (R) -1; 8-cylinder models (F) 6 (R) -1.

K/5 BLAZER

OPTIONS AND ACCESSORIES WHEN INSTALLED BY CHEVROLET

Description	Option Number	Added Weight (F) (R)		Factory D & H§	List Price	Mfr's Suggested Retail Delivered Price◇
Radios: Pushbutton control. Includes front antenna						
AM.....	U63	7	2	—	\$ 67.00	\$ 67.00
AM/FM.....	U69	7	2	—	145.00	145.00
Seats, Front:						
<i>Auxiliary, One-Passenger.</i> Not available when bucket seats or CST is ordered. Includes RH sunshade, armrest and seat belt.....						
	AN3	25	30	—	78.00	78.00
<i>Bucket, Driver and Passenger.</i> Included when CST is ordered. Includes console, RH sunshade, armrest and seat belts.						
Without auxiliary top. Also includes front compartment color-keyed vinyl coated rubber floor mat.....						
	A50	16	17	—	162.00	162.00
With auxiliary top. Also includes front compartment color-keyed carpeting.....						
	A50	16	17	—	182.00	182.00
Seat, 3-Passenger Rear: Seat trim matches front seat. Available only when H78-15, L78-15 or 7.00-15 tires are ordered. Includes LH and RH rear armrests and (3) seat belts. C10 models also include HD rear springs.						
With standard front seat. Also includes black embossed rubber rear floor mat.....						
	AS3	3	135	—	121.00	121.00
With bucket seats with auxiliary top. Also includes color-keyed rear floor carpeting.....						
	AS3	3	135	—	121.00	121.00
With bucket seats without auxiliary top. Also includes color-keyed vinyl coated rubber rear floor mat.....						
	AS3	3	135	—	121.00	121.00
Shock Absorbers:						
<i>Front and Rear.</i> Heavy-duty.....						
	F51	(a)		—	15.00	15.00
<i>Rear.</i> Heavy-duty.....						
	G68	0	3	—	8.00	8.00
<i>Superlift Rear.</i> C10 models only.....						
	G66	0	4	—	46.00	46.00
Springs, Heavy-Duty:						
<i>Front</i>						
Capacity 1550-lb each. C10 models only.....						
	F60	(b)		—	6.00	6.00
Capacity 1750-lb each. K10 models only. Available only when G78-15/B or larger tires are ordered.....						
	F60	2	0	—	32.00	32.00
<i>Rear.</i> Capacity 2000-lb each. C10 models only. Included when rear seat is ordered.....						
	G50	0	7	—	18.00	18.00
Stabilizer, Front: C10 models only.....						
	F59	19	0	—	18.00	18.00
Steering, Power:						
C10 models only.....						
	N40	33	0	—	128.00	128.00
K10 models only. Available only when G78-15/B or larger tires are ordered.....						
	N40	33	0	—	144.00	144.00
Steering Wheel, Comfortilt: Available only when optional transmission is ordered.....						
	N33	2	0	—	56.00	56.00
Throttle Control: Manual.....						
	K31	1	0	—	14.00	14.00
Tires and Wheels: See following page						
Top, Auxiliary: Fiberglass with textured paint. K10 models available only when G78-15 or larger tires are ordered. Includes rear side windows, front door vent windows and frameless drop glass, upper lift gate with fixed rear window, courtesy lamps, shoulder belt anchor, RH sunshade and LH coat hook						
<i>White</i>						
	Z58	30	155	—	313.00	313.00
<i>Black</i>						
	Z59	30	155	—	313.00	313.00
Towing Device: Two front towing hooks. K10 models only....						
	V76	16	-3	—	18.00	18.00
Trim, Highlander Plaid Interior: Available only when auxiliary top and CST are ordered. Includes black carpeting, instrument panel, steering column and wheel. See <i>Interior and Exterior Color Selection Chart</i> for availability and ordering information.....						
		N.A.	N.A.	—	56.00	56.00
Wheel Covers: Not available when 6.50-16 or 10.00-16.5 tires are ordered						
<i>Bright Metal</i>						
C10 models only.....						
	PO1	4	4	—	26.00	26.00
K10 models only. Front units contain hub clearance holes.						
	PO1	4	4	—	29.00	29.00
<i>Special.</i> C10 models only.....						
	PA1	N.A.	N.A.	—	41.00	41.00

§ D&H amounts reflect provision for pass through of tire weight tax imposed on manufacturer or importer of tires.

◇ State and local taxes not included.

(a) C models (F) 4 (R) 4; K models (F) 3 (R) 3.

(b) CS models (F) 2 (R) 0; CE models (F) 16 (R) 0.

K/5 BLAZER

Tire Size and Type	Rim Width Included In Tire Option	Option Number	Added Weight (F) (R)	Factory D & H§	List Price	Mfr's Suggested Retail Delivered Price◇
--------------------	-----------------------------------	---------------	----------------------	----------------	------------	---

All tires have black sidewalls except as indicated.
 Note: Front and rear tires must be of the same construction, rim width and diameter. K10 models require use of same tread type on front and rear wheels.

TUBE-TYPE TIRES (Factory Installed)

G78-15/B						
(Pass. — Highway type)	(5) Front, rear and spare	6.00	RL5	10	21	\$ 1.40 \$ 37.00 \$ 38.40
Bias	(2) Front; C10 models only	6.00	RL5	12	0	.56 14.80 15.36
Belted Ply	(3) Front and spare; C10 models only	6.00	RL5	10	8	.84 22.20 23.04
—On-Off Road						
Bias	(5) Front, rear and spare; K10 models only	6.00	RL4	11	21	1.40 37.00 38.40
Belted Ply	(2) Rear; C10 models only	6.00	RL4	0	13	.56 14.80 15.36
	(3) Rear and spare; C10 models only	6.00	RL4	7	13	.84 22.20 23.04
6.50-16/C						
(Pass. — Highway type)	(5) Front, rear and spare	5.00	R61	12	20	2.10 66.00 68.10
Original Equipment	(2) Front; C10 models only	5.00	R61	13	0	.84 26.40 27.24
	(3) Front and spare; C10 models only	5.00	R61	12	7	1.26 39.60 40.86
—On-Off Road						
Original Equipment	(5) Front, rear and spare; K10 models only	5.00	R69	14	31	2.10 66.00 68.10
	(2) Rear; C10 models only	5.00	R69	0	16	.84 26.40 27.24
	(3) Rear and spare; C10 models only	5.00	R69	-1	26	1.26 39.60 40.86
7.00-15/C (6PR) Maximum Tire Capacity (Each)—Front (1720) Rear (1720)						
(Truck—Highway type)	(5) Front, rear and spare	6.00	R44	23	42	3.70 133.50 137.20
Nylon	(2) Front; C10 models only	6.00	R44	N.A.	N.A.	1.48 53.40 54.88
	(3) Front and spare; C10 models only	6.00	R44	N.A.	N.A.	2.22 80.10 82.32
—On-Off Road						
Nylon	(5) Front, rear and spare; K10 models only	6.00	R43	28	52	5.80 133.50 139.30
	(2) Rear; C10 models only	6.00	R43	0	32	2.32 53.40 55.72
	(3) Rear and spare; C10 models only	6.00	R43	-4	52	3.48 80.10 83.58

TUBELESS TIRES (Factory Installed)

E78-15/B						
(Pass. — Highway type)	(5) Front, rear and spare	6.00	Std			N.C. N.C. N.C.
Bias						
Belted Ply						
G78-15/B						
(Pass. — Highway type)	(5) Front, rear and spare	6.00	PU7	7	13	1.65 34.00 35.65
Bias	(2) Front; C10 models only	6.00	PU7	8	0	.66 13.60 14.26
Belted Ply	(3) Front and spare; C10 models only	6.00	PU7	7	5	.99 20.40 21.39
	(5) Front, rear and spare (White Stripe)	6.00	PUB	7	13	1.65 65.60 67.25
—On-Off Road						
Bias	(5) Front, rear and spare; K10 models only	6.00	RL3	11	19	1.65 34.00 35.65
Belted Ply	(2) Rear; C10 models only	6.00	RL3	0	12	.66 13.60 14.26
	(3) Rear and spare; C10 models only	6.00	RL3	-1	19	.99 20.40 21.39
H78-15/B						
(Pass. — Highway type)	(5) Front, rear and spare	6.00	PV5	12	20	2.80 57.00 59.80
Bias	(2) Front; C10 models only	6.00	PV5	13	0	1.12 22.80 23.92
Belted Ply	(3) Front and spare; C10 models only	6.00	PV5	12	7	1.68 34.20 35.88
	(5) Front, rear and spare (White Stripe)	6.00	PV6	12	20	2.80 91.70 94.50
—On-Off Road						
Bias	(5) Front, rear and spare; K10 models only	6.00	RM1	13	26	2.80 57.00 59.80
Belted Ply	(2) Rear; C10 models only	6.00	RM1	0	16	1.12 22.80 23.92
	(3) Rear and spare; C10 models only	6.00	RM1	-1	24	1.68 34.20 35.88
L78-15/B						
(Pass. — Highway type)	(5) Front, rear and spare	6.00	Q15	16	29	4.15 103.00 107.15
Bias	(2) Front; C10 models only	6.00	Q15	18	0	1.66 41.20 42.86
Belted Ply	(3) Front and spare; C10 models only	6.00	Q15	16	11	2.49 61.80 64.29
	(5) Front, rear and spare (White Stripe)	6.00	Q14	16	29	4.15 144.00 148.15
—On-Off Road						
Bias	(5) Front, rear and spare; K10 models only	6.00	Q16	18	32	4.15 146.50 150.65
Belted Ply	(2) Rear; C10 models only	6.00	Q16	0	20	1.66 58.60 60.26
	(3) Rear and spare; C10 models only	6.00	Q16	-2	32	2.49 87.90 90.39

TUBELESS FLOTATION-TYPE TIRES (Factory Installed)

10.00-16.5/C (6PR) Maximum Tire Capacity (Each)—Front (2330) Rear (2330)						
(Truck—Highway type)	(5) Front, rear and spare; K10 models only	8.25	R79	65	117	9.20 461.80 471.00
Nylon						
—On-Off Road	(5) Front, rear and spare; K10 models only	8.25	RR2	67	123	11.10 464.50 475.60
Nylon						

§ D&H amounts reflect provision for pass through of tire weight tax imposed on manufacturer or importer of tires.
 ◇ State and local taxes not included.

K/5 BLAZER

BLAZER—STANDARD MODEL

The standard model includes the following items as standard equipment.

EXTERIOR FEATURES



- **Bright Appearance Items:**

- Chevrolet Emblem: Mounted center of grille with bright outer edge and blue paint fill
- "K/5 Blazer" Nameplate: Side of each front fender
- Door Entry Handles
- Door Lock Cylinder Assemblies
- Grille: Bright anodized aluminum outer area and inner plastic grid with black and gray colors
- Headlamp Bezels
- Mirrors: Chrome RH & LH

- **Bumpers:** Front and rear; painted white

- **Color:** See Exterior and Interior Color Selection Chart

- **Doors:** RH and LH side doors and tailgate

- **Glass:** Windshield only

- **Lights:**

- Back-up lights: two rear
- Combination parking/direction/hazard: two front Class A
- Combination tail/stop/direction/hazard: two rear Class A
- Headlights: Two; Power Beam
- License Plate: Single rear
- Side Marker and Reflectors: two front and two rear

- **Mirrors:** RH & LH chrome fixed arm with 4½" x 6" head

- **Horn:** Single; low note; electric

- **Hub Caps:** Painted white with black and blue trim (CS/CE models only)

- **Tools:** Mechanical jack; wheel wrench

- **Undercoating:** Partial on underbody and full under front and rear wheelhousings

- **Wheels:** Painted white

- **Windshield Wipers and Washers:** Electric; 2-speed wipers with matte finish on wiper arms and blades

INTERIOR FEATURES

- **Air Vents:** RH and LH cowl side; individually controlled

- **Arm Rests:** RH and LH integral with door trim panel

- **Ash Tray:** Mounted middle of instrument panel

- **Colors:**
Paint: Same as main exterior color choice
Trim Color Choice of parchment, black or blue

- **Door Locks:** Inside; pushbutton lock/release

- **Door Seals:** Closed-cell-type rubber

- **Door Trim Panels:** Embossed molded plastic

- **Floor Mats:** Front only; embossed black rubber

- **Instruments**

- Gauges: Speedometer, odometer, and fuel
- Switches: Exterior lights, instrument lights, and dome lights; wiper-washer; headlight beam (foot); ignition, direction signal with lane change position and hazard warning
- Warning Lights: Generator, oil pressure, engine temperature, brake warning, direction signals-hazard and high beam

- **Instrument Cluster Bright Trim:** Outer edge and bezels

- **Instrument Panel Pad:** Top of panel

- **Heater and Defroster:** Deluxe-air

- **Interior Lights:** Instrument cluster operated by main light switch

- **Insulation and Deadening Material:** Dash (firewall) and under the floor mat

- **Mirror, Rearview:** 10" vinyl-edged; prismatic

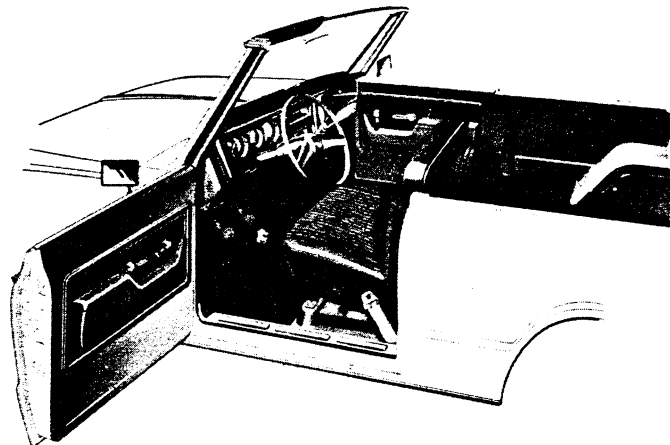

- **Seat:** Driver only; bucket type with vinyl trim and foam padding

- **Seat Belts:** Includes retractor; pushbutton release; driver only

- **Steering Wheel:** Painted; oval 17" x 17½", 2-spoke

- **Sunshade:** LH padded

- **Scuff Plate:** Door opening protection and floor mat retainer

- **Spare Tire Mounting:** On floor behind driver seat

K/5 BLAZER

CUSTOM SPORT TRUCK (CST) MODEL OPTION—RPO Z84

(This option includes all standard items except for the following additions or substitutions)

EXTERIOR FEATURES

Optional Chrome Hub Caps, Top, Side Windows, and white stripe Tires also shown in illustration

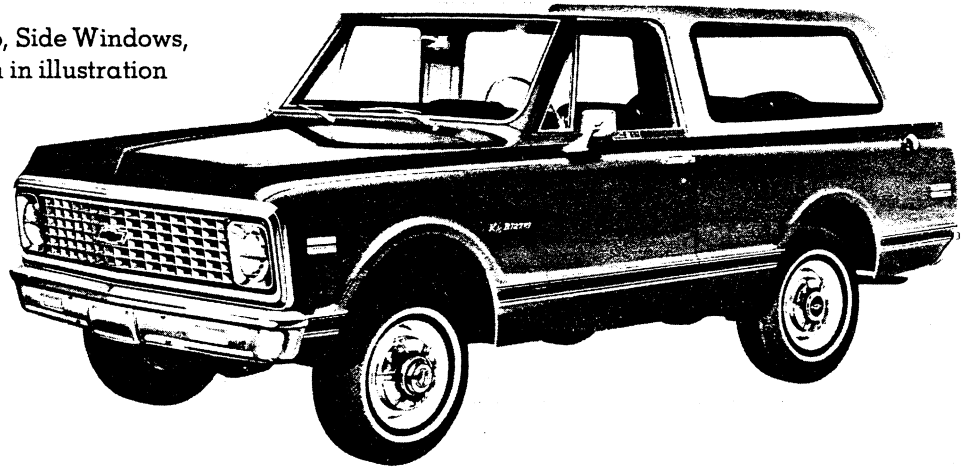

- **Bright Metal Appearance Items:**

- "Chevrolet" Tailgate Trim Panel with woodgrain insert and upper trim molding
- Chrome front and rear bumper
- Chrome fuel tank cap
- "CST" Nameplate: Side of each front door
- Lower side trim moldings with woodgrain insert
- Tail and Backup light bezels
- Ventipane frames (Included when optional top or side door glass is ordered)
- Windshield Reveal Moldings

- **Horn:** Additional; high note; electric

- **Special Cowl Insulators**

- **Special Side Marker** Lights/Reflectors with bright trim

- **Undercoating:** Full underbody sprayed with mastic coating

INTERIOR FEATURES

- **Bright Metal Appearance Items:**

- Control Knob Inserts
- 4-Speed Transmission Shift Lever
- Transfer Case Shift Lever (4-Wheel-Drive models)
- Trim moldings on clutch, service brake, parking brake, and accelerator pedals
- Rear Compartment Trim Panel Retainers

- **Cigar Lighter**

- **Floor Covering:** Color-keyed carpeting (when optional top is ordered) or rubber color-keyed (without optional top). Rear compartment floor covering provided only with optional rear seat.

- **Seats:** Bucket seats with console; driver and passenger; all vinyl trim available in choice of black, blue, saddle, parchment, or olive

- **Spare Tire Cover:** (Included when optional top is ordered)

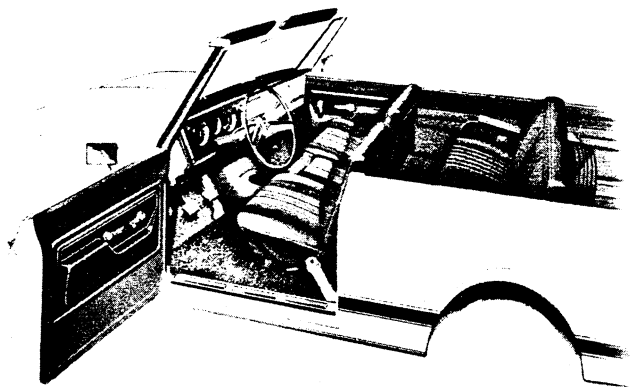

Optional 3-passenger rear seat also shown in illustration.

- **Sunshade:** RH padded (without optional top)

- **Trim Panels:** Molded plastic with wood-grained inserts and bright trim for front doors; embossed vinyl for rear compartment sidewalls (included when optional top is ordered)

K/5 BLAZER INTERIOR AND EXTERIOR COLOR CHART

All orders for these models must show one of the following interior trim codes on the order form

IMPORTANT

Dealer Note: Exterior and interior combinations shown in chart below are those recommended by Chevrolet; however, any exterior color may be ordered with any available interior color if the particular combination is desired by a customer.

BLAZER MODELS

INTERIOR TYPE	Type of Seat	INTERIOR TRIM COLOR AND CODE							
		Avocado	Black	Blue	Gray	Orange	Olive	Parch-ment	Saddle
Standard Interior	Vinyl Bucket		668	674				694	
(A50) Bucket Seats	Vinyl Bucket		670	676				694	
(Z84) Custom Sport Truck—Vinyl	Vinyl Bucket		670	676			698	694	688
(Z84) Custom Sport Truck—Highlander Flaid (with auxiliary top only)	Cloth/Vinyl Bucket	680		677	671	686			
EXTERIOR COLOR									
SOLID	Option Number								
Black, Midnight	500	X	X	X	X	X		X	X
Blue, Hawaiian	510		X	X	X			X	
Blue, Mariner	523		X	X	X			X	
Bronze, Classic	522		X		X			X	X
Gold, Spanish	511		X		X			X	X
Green, Glenwood	505		X		X			X	
Green, Meadow	518		X		X			X	
Green, Spruce	506	X			X		X	X	
Green, Willow	504	X	X		X		X	X	X
Orange, Firebolt	524		X		X	X		X	
Orange, Tangier	516	X	X		X	X		X	
Red, Crimson	514		X		X			X	X
White, Frost	521	X	X	X	X	X	X	X	X
Yellow, Grapefruit	525	X	X		X	X		X	X
Yellow, Wheatland	519		X		X	X		X	