

COMPACT & FULL-SIZE PICKUPS

1 9 9 1 C H E V Y T R U C K S



Chevrolet's 1991 theme line, "More People Are Winning With The Heartbeat of America," is especially true regarding Chevy Pickups.

For one thing, Chevy offers more pickup models for work and play than anybody else. The '91 Chevy lineup includes compact pickups, full-size pickups, Fleetside styling, Sportside styling, 2WDs or 4x4s, Regular-Cabs, Maxi-Cabs, Extended-Cabs, long boxes, short boxes, chassis-cab models and other special models for working extra hard or looking extra good.

Equally important, Chevy trucks are built better than ever, and we're backing them up with the best Chevy warranty ever written (see page 66).

Once you've checked out all the pickup trucks in this brochure, put us to the test with a demonstration drive of the Chevy of your choice at your Chevy truck dealer's. At that point, we think you'll fully agree with another Chevy sentiment: "Today's Truck is Chevrolet."

CONTENTS

S-10 Pickup	4
EL / Standard.....	6
Tahoe / Maxi-Cab.....	8
Baja	10
Special Features	12
C/K Pickup	20
Cheyenne & W/T1500	22
Scottsdale.....	24
Silverado	26
Sport / Sportside.....	28
454 SS	30
Special Features	32
Extended-Cab.....	34
Special Applications	36
Chassis-Cabs and Special Bodies.....	38
R/V Pickup	52
Crew Cab, Bonus Cab and Chassis-Cab	54
Trailerling	60
Four-Wheeling Tips	64
Additional Information ...	66



S-10 Pickup with optional Tahoe Value Package and optional Deluxe Two-Tone in Apple Red and Silver Metallic.

K2500 Short-Box Extended-Cab Pickup in Brilliant Blue Metallic with optional Scottsdale trim.

R3500 Crew Cab Pickup in Apple Red with Big Dooley dual-rear-wheel option.

5-10 COMPACT PICKUP 1997



C3500 straight-rail Chassis-Cab in Summit White with stake body provided by outside supplier.

WT1500 Work Truck in Smoke Blue Metallic with 8-ft. box.

C1500 454 SS model in Onyx Black with luxury-level Silverado trim.

K1500 Sportside Short-Box (6 1/2 ft.) in Summit White with optional Silverado trim.

Tires supplied by various manufacturers.

Your personal pickup is ready and willing.

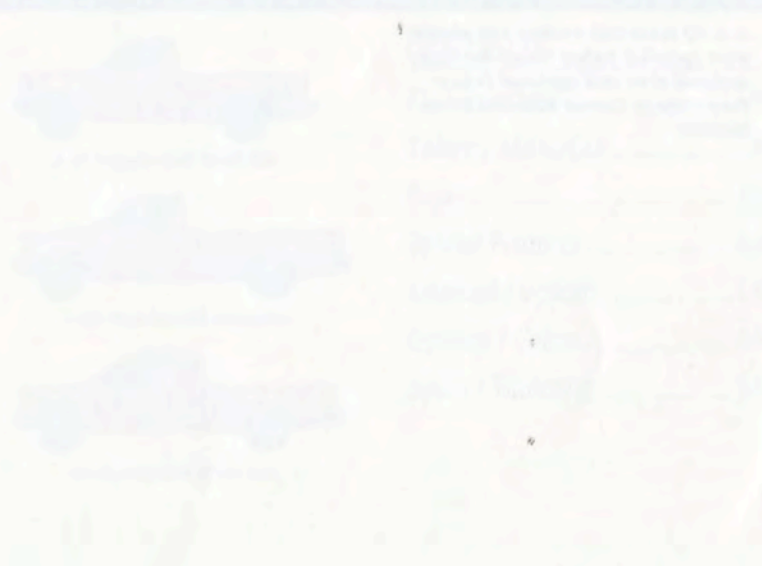

1991 CHEVY PICKUPS S-10 / C/K / R/V

TRUCK LINES	Engines		Body Styles		Cab Types		Seating	Cargo Box		Special Trucks
	Gas	Diesel	Fleetside / Sportside		Regular / Extended			Short / Long		
S-10 Compact (2WD and 4x4)	2.5 Liter (151 Cu. In.) L4									S-10 EL (page 6)
	2.8 Liter (173 Cu. In.) V6	—	All	—	2-Door Regular-Cab	2-Door Maxi-Cab	2, 3, 4	6 ft.	7 1/3 ft.	Tahoe Value Package (page 8)
	4.3 Liter (262 Cu. In.) V6									Baja (page 10)
C/K Full-Size (2WD and 4x4) 1/2-Ton 3/4-Ton 1-Ton	4.3 Liter (262 Cu. In.) V6									W/T1500 (page 22)
	5.0 Liter (305 Cu. In.) V8									Sport (page 28)
	5.7 Liter (350 Cu. In.) V8	6.2 Liter (379 Cu. In.) V8	All	1/2-Ton Regular-Cab Short-Box 2WD / 4x4	2-Door Regular-Cab	2-Door Extended-Cab	2, 3, 5, 6	6 1/2 ft.	8 ft.	454 SS (page 30)
	7.4 Liter (454 Cu. In.) V8									Chassis-Cab (page 38)
R/V Full-Size (2WD and 4x4) 1-Ton	5.7 Liter (350 Cu. In.) V8									
	7.4 Liter (454 Cu. In.) V8	6.2 Liter (379 Cu. In.) V8	All	—	—	4-Door Crew Cab or Bonus Cab	3, 6	—	8 ft.	Chassis-Cab (page 54)

'91 Chevy—three distinctive product lines to meet every pickup need.

Whether you want a pickup truck for hard days on the job or for your own personal brand of fun, Chevy has just the right truck for you.

Choose from many models in three separate truck lines: the S-10 Compact Pickup, the new-generation C/K Full-Size Pickup, and the long-established R/V Full-Size Pickup.

As the photo to your left suggests, Chevy offers more ways to go with pickups than any other truck company. There's a Chevy pickup for your toughest job, your most challenging outdoor adventure, and everything in between. The chart above will give you a quick overview of 1991 Chevy Pickup offerings.



▲ S-10 Maxi-Cab Pickup 4x4 shown with optional Tahoe Value Package, optional tires and optional Deluxe Two-Tone in Garnet Red and Silver Metallic.

Your personal pickup is ready and willing.



S-10 Regular-Cab Short-Box.



S-10 Regular-Cab Long-Box.



S-10 Maxi-Cab Short-Box.

CONTENTS

- EL / Standard6
- Tahoe / Maxi-Cab8
- Baja10
- Special Features12
- Standard / Options14
- Options / Colors16
- Specs / Trailering18

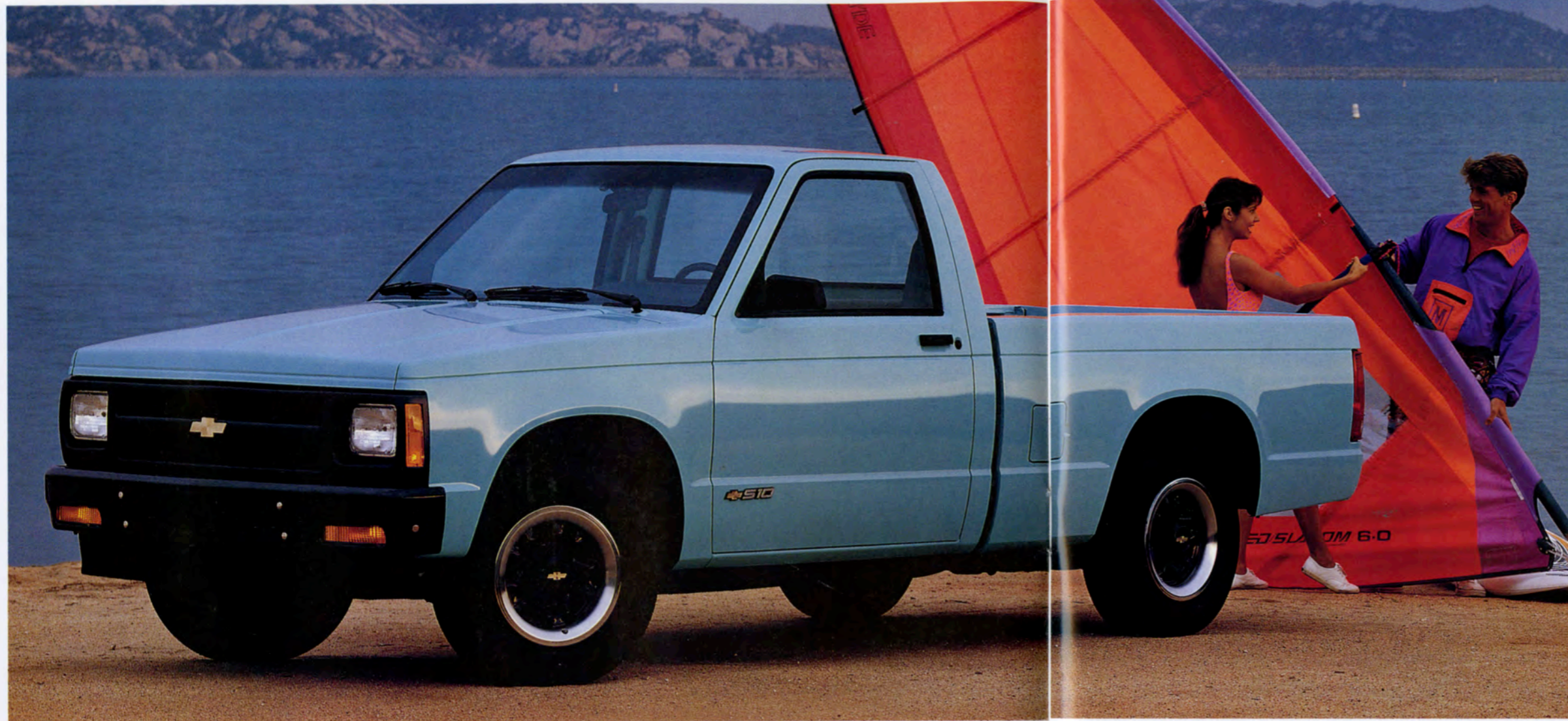

Chevy's most affordable pickups.

The Chevy S-10 EL is Chevy's most popular compact pickup, and with good reason. It is not only the lowest-priced, but also has the same tough-truck build as the entire S-10 line. To keep the EL eminently affordable, we make it available only as a Regular-Cab Short-Box 2WD model with limited options.

S-10 EL options include an option package consisting of a rear step bumper, 20-gallon fuel tank and full-size spare tire. Like the standard S-10, the S-10 EL has a foam-cushioned, 3-passenger bench seat in your choice of Custom Vinyl or Custom Cloth.

The standard S-10 Pickup also wears an attractive price tag but is available in a wider range of models, including Regular-Cab and Maxi-Cab, Short-Box and Long-Box, and

2WD and 4x4. Like all 1991 models, the S-10 EL and the standard model have received exterior appearance changes including a new front grille.

Both models have the improved 2.5-liter (151 cu. in.) L4 engine with Electronic Fuel Injection, a 5-speed manual transmission with overdrive, a rear-wheel anti-lock brake system*, a front stabilizer bar and tinted glass.

The S-10 4x4 models also feature the patented "shift-on-the-fly" Insta-Trac 4x4 system. Insta-Trac allows you to shift in and out of 4-wheel drive without stopping or backing up.

*Operates in 2WD mode only.



▲ Standard Regular-Cab S-10 2WD Long-Box in Aspen Blue Metallic.

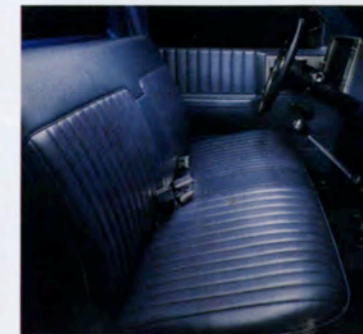

▲ The S-10 EL and standard S-10 Custom Vinyl interior, shown in Blue.

◀ S-10 EL in Mint Green.



▲ S-10 Regular-Cab 2WD with optional Tahoe Value Package and optional Deluxe Two-Tone in Royal Blue Metallic and Silver Metallic.

▶ S-10 Maxi-Cab interior in Garnet Red with optional luxury-level Tahoe trim featuring Special Custom Cloth front seats and optional vinyl rear jump seats. This Tahoe interior trim is identical to the one you get if you order the Tahoe Value Package.

◀ S-10 Maxi-Cab 2WD in Apple Red with optional Tahoe Trim.



Top-of-the-line luxury—with Maxi-Cab spaciousness.

A Chevy S-10 with the optional luxury-level Tahoe trim has a look and feel all its own. And, when combined with the Maxi-Cab model (which is available with any S-10 trim level), it breaks new ground in personal transportation.

Tahoe's special touches include: front-end chrome and body-molding accents; Rally Wheels with trim rings on 2WD models, and black steel wheels with trim rings on 4x4 models; special tailgate applique; black exterior mirrors; black body-side moldings with bright trim; bright wheel-opening moldings; wall-to-wall color-keyed carpeting; Deluxe steering wheel; and Deluxe headliner. Extra insulation and sound-deadening materials add up to a surprisingly quiet ride.

The S-10 Pickup in the upper right-hand corner of this page has a new option called the Tahoe Value Package. If you order a 2WD S-10 Pickup with manual transmission

and optional Preferred Equipment Group 6 (which includes luxury-level Tahoe trim), you get a V6 engine at no extra cost in place of the S-10's standard 4-cylinder engine. If you order a 4x4 S-10 Pickup with optional automatic transmission and optional Preferred Equipment Group 6, you get a set of 15-inch cast-aluminum wheels at no extra cost. See page 15 for a full description of Preferred Equipment Group 6 and the Tahoe Value Packages built around it.

The Maxi-Cab model shown above features an extended cab on a longer (122.9-in.) wheelbase than the regular S-10. Maxi-Cab gives a choice of additional in-cab storage space or optional 4-passenger seating with optional front bucket seats and two rear jump seats. The rear seats fold up out of the way to allow 13.7 cu. ft. of in-cab storage space.

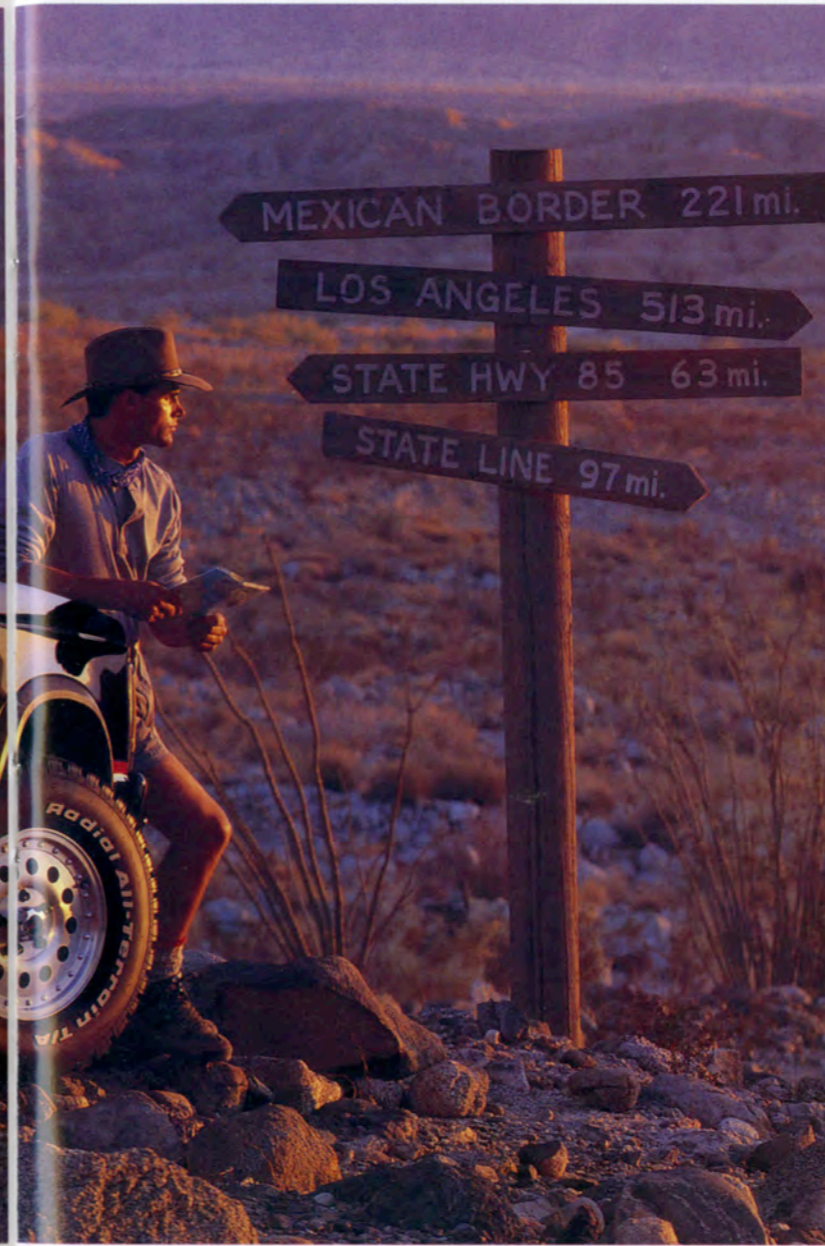

▲ Regular-Cab S-10 Baja special cloth interior in Charcoal/Bittersweet Red. The Baja interior includes front bucket seats with reclining seat-backs in Maxi-Cab 4x4 models.

The desert cruiser — or downtown cruiser.

Technically, the Baja is an optional off-road appearance package. But, as your eyes will tell you, it's a lot more than that. It's style ... moxie ... and a look that gives you a real sense of mastering the road — or the off-road.

The S-10 Baja comes in Midnight Black, Apple Red or Frost White. Its macho distinctions include a light bar* with off-road lamps, a front grille guard with driving lamps, and a tubular rear bumper. Other exterior touches that set the S-10 Baja apart include LT235/75R-15 all-terrain T/A white-lettered tires, special brushed aluminum wheels, black grille with black headlight and taillight bezels, plus unique "Baja" graphics.

Special Baja-only options include a cargo-net endgate and a special pickup-box-mounted spare tire carrier. Required options for the Baja package include the luxury-level Tahoe interior trim, an underbody shield package and a suspension package.

Although shown here as a Regular-Cab S-10 Short-Box, the Baja package is also available as a Maxi-Cab S-10 Short-Box model.

*The light bar on this truck is not a roll bar. The light bar won't protect you in an accident.



Midnight Black.



Apple Red.



Frost White.

◀ S-10 Pickup 4x4 in Midnight Black with optional Baja off-road appearance package and selected options. Note: The light bar on this truck is not a roll bar. The light bar won't protect you in an accident.

▼ The standard rear-wheel anti-lock brake system, which operates in the 2WD mode only, features a sensor designed to monitor wheel speed. When the brakes are applied, the system automatically modulates the brakes as necessary to minimize rear-wheel lockup.

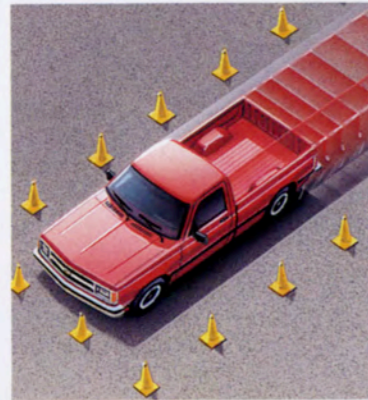

▼ Talk about S-10 toughness: Larry Ragland's race-modified "American Thunder" S-10 2WD has finished every event it's entered since 1987, and Larry has driven it to Class 7 victories in both the 1988 and 1990 SCORE/HDRA Off-Road World Championships.



Designed and built around the people it carries.

As you view the road from the cockpit of a Chevy S-10 Pickup, you'll do so in a world of style and comfort. And you'll do it for many years to come, because every S-10 is built for the long haul. Each S-10 Pickup benefits from computer-aided design, precision manufacturing processes, top-grade materials, a multi-layer exterior finish, intensively trained assemblers and a quality-control system that's based on a team concept. Extensive anti-corrosion measures are also taken during manufacture, so additional rustproofing is not required.

Beyond the way it is put together, the S-10 Pickup has the right product content to enhance the way many Americans drive today. The Chevy S-10 lineup comes in a wide range of models—with a broad selection of optional equipment—to meet your individual needs. Check out the complete list of options on pages 15-16.

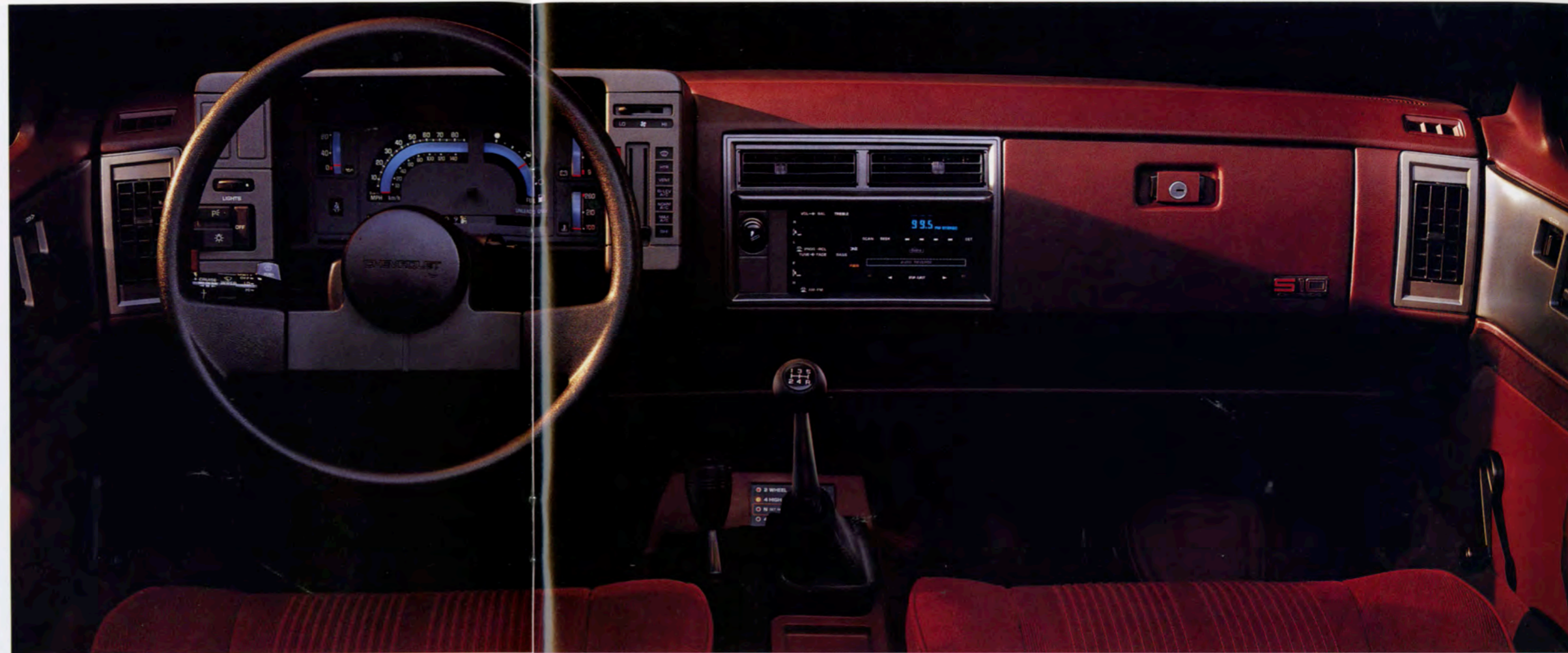

▲ The S-10 instrument panel is designed with an eye to style and practicality. The cluster has bold easy-to-read graphics, and controls are grouped within easy reach.

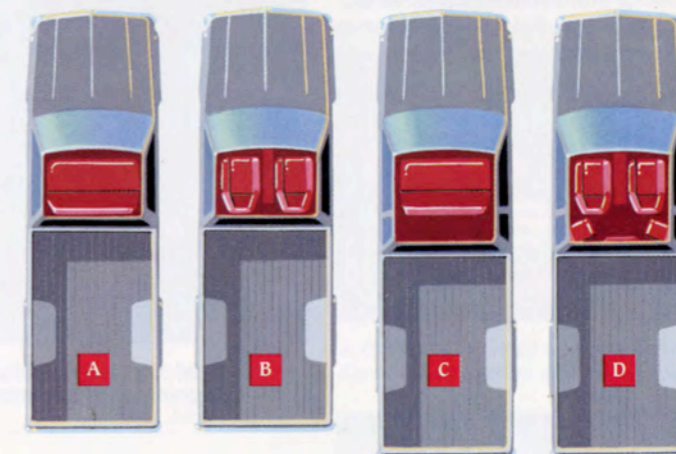

◀ With S-10 Pickup, your seating choices include places for two, three or four people, as indicated by the diagrams to your left. All seating plans provide in-cab storage space, with a maximum of 18.3 cu. ft. behind the Maxi-Cab's standard bench. Although the S-10's depicted here all have short boxes, most Regular-Cab models can be ordered with long boxes, too. The exception is S-10 EL, which comes only as a short-box model, and is further restricted to a 3-passenger bench.

- A. Regular-Cab with standard 3-passenger bench.
- B. Regular-Cab with optional bucket seats.
- C. Maxi-Cab with standard 3-passenger bench.
- D. Maxi-Cab with optional front bucket seats and two rear jump seats. (also available without two rear jump seats.)

MODEL SELECTORS



S-10 Regular-Cab Short-Box.



S-10 Regular-Cab Long-Box.



S-10 Maxi-Cab Short-Box.

MODELS	Regular-Cab		Maxi-Cab
	Short-Box	Long-Box	Short-Box
Std. Seating Capacity	3	3	3
Opt. Seating Capacity	2	2	2, 4
Drives	2WD, 4x4	2WD, 4x4	2WD, 4x4
Wheelbase (in.)	108.3	117.9	122.9
Box Size	6 ft.	71/3 ft.	6 ft.
Std./Max. GVWR (lbs.) ¹	2WD: 4200/4600 4x4: 4650/5150	4200/4900 4650/5150	4200/4600 4650/5150
Min./Max Payload (lbs.) ²	2WD: 879/1865 4x4: 1060/1924	812/1973 1020/1834	713/1748 888/1799
Max. GCWR (lbs.) ³	9500	9500	9500
TRIM LEVELS ⁴	Standard		Tahoe ⁵
Std. Fabric	Custom Vinyl or Custom Cloth.		Custom Vinyl or Custom Cloth.
Opt. Fabric			Special Custom Cloth; leather trim.
Interior Colors ⁶	Blue, Garnet Red, Charcoal and Saddle.		Blue, Garnet Red, Charcoal and Saddle. (Leather-trimmed seats available with Maxi-Cab only in Charcoal and Saddle.)

SPECIAL MODELS & PACKAGES

S-10 EL	(See p. 6.)
Tahoe Value Package	(See p. 8.)
4x4 Baja	(See p. 10.)

¹ GVWR (Gross Vehicle Weight Rating) includes vehicle, passengers, equipment and cargo. ² Payload includes passengers, equipment and cargo. ³ GCWR (Gross Combined Weight Rating) includes vehicle, trailer, people, cargo and equipment. GCWR must be reduced by 1000 lbs. if P235/75R-15 tires are specified for any S-10 4x4. ⁴ Refer to charts on page 17 for seat type and color availability. ⁵ In the S-10 Baja 4x4, available only with special Charcoal buckets seats and trim. ⁶ Your choice of exterior color will determine your choice of interior color. See your Chevy truck dealer for details.

TRIM FEATURES

INTERIOR	EL/Std.	Tahoe
Armrests: Both doors, padded	■	■
Floor Coverings:		
Front embossed black rubber mats (also rear mats in Maxi-Cab)	■	
Color-keyed carpeting		
Color-keyed carpeting, including rear of cab		■
Grab Handle: Over passenger door (4x4 only)	■	■
Headliners:		
Cloth, color-keyed, partial	■	
Cloth, color-keyed, full-length		■
Glass: Tinted, all windows	■	■
Lights:		
Instrument cluster and cab interior (door-operated courtesy lights/dome light); shift point indicator light with manual transmission	■	■
Glove box and ashtray lights		■
Mirror: Rearview, 10" prismatic	■	■
INSTRUMENT PANEL / STEERING COLUMN		
Gages: Speedometer, odometer, trip odometer, fuel, voltmeter, engine temperature and oil pressure	■	■
Heater and Defogger: Deluxe outside-air type with side-window defoggers	■	■
Radio: AM, electronically tuned, with digital clock (except S-10 EL model)	■	■
Warning Buzzers:		
Key-in-ignition	■	■
Headlights-on		■
Warning Lights: Safety belt, service/parking brake, direction/hazard signal and high beams	■	■
DOOR PANELS		
Painted Areas: Same color as primary exterior color, trim color same as seat trim	■	■
Trim Panels:		
Color-keyed plastic with integral armrests	■	
Special Custom Cloth inserts with carpeted lower panels, map pockets, coin holder (in LH pocket)		■
SEATING		
Bench Seat: Foam-cushioned Custom Vinyl or Custom Cloth with folding seat-back (except Maxi-Cab Tahoe)	■	■
Bucket Seat: Foam-cushioned Custom Vinyl reclining high-back w/console (Maxi-Cab only)		■
Safety Belts: All seating positions, with lap/shoulder belts at all front-seat outboard seating positions	■	■
EXTERIOR		
Bumpers:		
Front, painted black, with parking lamps	■	
Front, chromed, with rub strip		■
Moldings:		
Body-side, black with bright accent		■
Wheel-opening, bright aluminum		■
Windshield, black	■	■

S-10 COMPACT PICKUP STANDARDS / OPTIONS

PREFERRED EQUIPMENT GROUPS

TRIM LEVELS	Standard	Tahoe
GROUP 1 (Standard Body)	■	■
GROUP 6		
Tahoe Trim Level		■
Bumper: Rear Step		■
Lighting: Auxiliary		■
Paint: Deluxe Two-Tone		■
Radio: ETR AM/FM Stereo w/Seek-Scan, Cassette Tape Player and Digital Clock		■
Seats: Rear Jump (available only in Maxi-Cab)		■
Seats: Bucket, Custom Reclining High-Back (available only in Maxi-Cab)		■
Steering, Power (std. in 4x4 models)		■
Tires: P205/75R-14 White-Lettered All-Season Radials (2WD models only)		■
Tires: P205/75R-14 White-Lettered On-/Off-Road (4x4 models only)		■
Window: Sliding, Rear (Regular-Cab models only)		■

NOTE: See your Chevy truck dealer for Preferred Equipment Groups for S-10 EL and Baja models.

These convenient option packages make it easy to tailor the S-10 Pickup to your exact specifications and can save you money. You would pay appreciably more buying all the options in a Preferred Equipment Group as individual options. (Savings based on comparison of Manufacturer's Suggested Retail Price of option packages versus M.S.R.P. of individual options purchased separately.)



▲ Optional tinted, nonremovable, manually operated sunroof. (With Tahoe trim, an optional sliding rear window is required.)

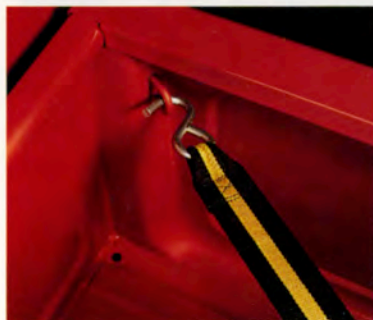

▲ Standard cargo hooks in every S-10 Pickup box make easy work of tying down payloads or "playloads."



▲ The Regular-Cab seat-back folds forward for access to storage space.

TAHOE VALUE PACKAGE - 2WD S-10 MANUAL TRANSMISSION.

If you order your 1991 S-10 Pickup 2WD with Preferred Equipment Group 6 *and* a standard manual transmission, you get a 2.8 Liter (173 Cu. In.) V6 engine at no extra cost, instead of the standard 2.5 Liter (151 Cu. In.) L4 engine.

TAHOE VALUE PACKAGE - 4x4 S-10 AUTOMATIC TRANSMISSION.

If you order your 1991 S-10 Pickup 4x4 with Preferred Equipment Group 6 *and* an optional 4-speed automatic transmission with overdrive, you get a set of 15" cast-aluminum wheels at no extra cost.



▲ Optional fog lamps can be ordered for standard air dam on 2WD models. Standard air dam on 4x4 models includes tow hooks.



▲ An optional auxiliary light package includes an inside rearview mirror with built-in reading lamps.



▲ A 5-speed manual transmission with overdrive is standard.

INDIVIDUALLY AVAILABLE OPTIONS

(May be added to any Preferred Equipment Group if not already included. See your Chevy dealer for details on individually available options for EL and Baja.)

TRIM LEVEL	EL/Std.	Tahoe
Air Conditioning	■	■
Bumpers:		
Rear step, painted black w/rub strip	■	
Rear step, chromed w/rub strip		■
Console: Center (requires front bucket seats; included with Tahoe trim in Maxi-Cab)	■	■
Cooling Systems:		
Heavy-duty radiator	■	■
Heavy-duty radiator and transmission oil cooler	■	■
Heavy-duty radiator and engine oil cooler	■	■
Driver Convenience Group: Comfortilt steering wheel and intermittent wipers	■	■
Floor Covering:		
Rubber: Full floor, Charcoal	■	N/A
Carpet: Full floor	■	■
Mats: Removable, color-keyed	N/A	■
Glass: Deep-tinted (incl. swing-out rear-quarter windows in Maxi-Cab, N/A w/sliding rear window)	■	■
Instrumentation: Electronic (N/A w/2.5 Liter EFI L4)	■	■
Lighting: Auxiliary	■	■
Mirrors:		
Exterior, Below Eyeline, Black	■	■
Lighted Visor: LH and RH	■	■
Moldings: Wheel-opening, Black	■	■
Operating Convenience Group: Power door locks and power windows	■	■
Shield Package: 4x4 only (incl. transfer case and front differential skid plates, fuel tank and steering linkage shields)	■	■
Shock Absorbers: Heavy-duty, front and rear (N/A w/4x4 Suspension Package, incl. w/heavy-duty front springs or 2WD Sport Suspension Package w/o 4.3 V6)	■	■
Speed Control: Electronic	■	■
Springs:		
Front, heavy-duty (4x4 only — incl. heavy-duty front/rear shocks, N/A w/4x4 Suspension Package)	■	■
Rear, heavy-duty (N/A w/P195/75R-14 B/W tires)	■	■
Steering: Power (std. on 4x4 and Maxi-Cab, incl. w/ 2WD Sport Suspension, req. w/4.3L V6 engine)	■	■
Sunroof: Manual (requires sliding rear window when ordered w/Tahoe trim)	■	■
Suspensions:		
2WD Sport Suspension Package	■	■
4x4 Suspension Package	■	■
Window: Sliding rear	■	■

■ - Optional, ■ - Included, N/A - Not Available.



▲ Standard ETR AM radio with digital clock (optional in EL model).



▲ Optional ETR AM/FM stereo radio with premium dual rear speakers, seek and scan and digital clock.



▲ Optional ETR AM/FM stereo radio with premium dual rear speakers, seek and scan, stereo cassette tape player and digital clock.



▲ Optional ETR AM stereo¹/FM stereo radio with premium dual rear speakers, seek and scan, graphic equalizer and digital clock, plus stereo cassette tape player with search and repeat.

¹ Receives C-Quam[®] AM stereo broadcasts. Most AM stations across the country broadcast in C-Quam, but some do not. Check with your local stations for compatibility in your area.



A. Standard 14" wheels (2WD).

B. Optional 14" Rally Wheels (2WD) with trim rings (incl. with Tahoe trim).

C. Standard 15" wheels (4X4).

D. Optional 15" cast-aluminum wheels (4x4).

E. Standard 15" brushed-aluminum wheels (Baja 4x4 only).

S-10 COMPACT PICKUP OPTIONS / COLORS

INTERIOR COLORS	Blue	Charcoal	Garnet	Saddle
STANDARD INTERIOR				
Custom Vinyl Bench Seat	■	■	■	■
Custom Cloth Bench Seat	■	■	■	■
Custom Vinyl High-Back Bucket Seats (with Reclining Seat-Backs in Maxi-Cab Models)	■	■	■	■
TAHOE INTERIOR				
Custom Vinyl Bench Seat	■	■	■	■
Custom Cloth Bench Seat	■	■	■	■
Custom Vinyl High-Back Bucket Seats (with Reclining Seat-Backs and Console in Maxi-Cab Models)	■	■	■	■
Special Custom Cloth High-Back Bucket Seats (with Reclining Seat-Backs and Console in Maxi-Cab Models)	■	■	■	■
Leather-Trimmed Reclining High-Back Bucket Seats and Console (Maxi-Cab Models Only)		■		■

EXTERIOR COLORS ¹	Blue	Charcoal	Garnet	Saddle
Midnight Black		■	■	■
Aspen Blue Met. ²	■	■		
Sky Blue ²	■			
Royal Blue Met. ²	■	■		
Garnet Red ²		■	■	■
Steel Gray Met. ²		■	■	
Apple Red		■	■	
Wheat ²				■
Frost White	■	■	■	■
Mint Green ²		■		

¹ Ask your Chevy truck dealer for information on Special and Deluxe Two-Tone combinations. ² Not available with Baja optional appearance packages.

SEAT AVAILABILITY	Regular-Cab ¹		Maxi-Cab ²	
	Standard	Tahoe	Standard	Tahoe
Custom Vinyl Bench Seat	■	■	■	■
Custom Cloth Bench Seat ³	●	●	●	●
Custom Vinyl Bucket Seats ⁴	●	●	●	●
Special Custom Cloth Bucket Seats ⁴	N/A	●	N/A	●
Leather-Trimmed Reclining Bucket Seats ⁴	N/A	N/A	N/A	●

■ - Standard. ● - Optional. N/A - Not available. ¹ Rear jump seats not available. ² Optional Maxi-Cab rear jump seats are in vinyl only, regardless of trim ordered for optional front bucket seats. ³ A no-extra-cost option. ⁴ Not available in S-10 EL.

OPTIONAL TWO-TONES



▲ **SPECIAL TWO-TONE** includes chromed front bumper with rub strip and striping at the beltline with secondary color applied below. Available with standard model only.



▲ **DELUXE TWO-TONE** includes secondary color between the beltline and the body-side moldings. Available with Tahoe only.

EXTERIOR COLORS

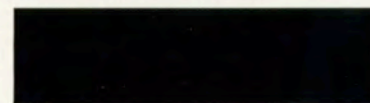

Midnight Black ¹



Aspen Blue Met.



Sky Blue



Royal Blue Met.



Garnet Red



Steel Gray Met.



Apple Red ¹



Wheat

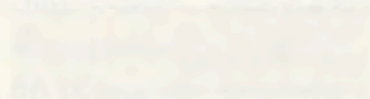

Frost White ¹



Mint Green



Silver Met. ²

¹ One of three colors available on S-10 Baja.
² Available only as a secondary color.

SPECS	2WD S-10/EL	4x4 S-10
Engine - Liters (cu. in.)	2.5 (151) EF14	4.3 (262) EFI V6
Front Suspension- Type	Independent-Coil Springs	Ind. Driving Axle-Torsion Bars
- Capacity lb.	2500	2700
Rear Suspension - Type	Two-Stage Multileaf	Two-Stage Multileaf
- Capacity lb.	2700	2700
Brakes - Front Disc/Rear Drum	Power	Power
Anti-Lock Brake System	Rear-Wheel ¹	Rear-Wheel ¹
Electrical		
- Battery (CCA)	525 CCA	525 CCA
- Generator (amp)	96 Amp	85 Amp
Fuel Tank - Capacity (gal.)	20.0 Gal./13.0 Gal	20.0 Gal
Steering	Power/Manual	Power
Transmission	5-Speed Manual w/OD	5-Speed Manual w/OD
Transfer Case	—	NP 231
Tires- All-Season Radial	(5) P195/75R-14 ²	(5) P205/75R-15
Wheels	(5) 14" x 6" ³	(5) 15" x 6"

¹ Operates in 2WD mode only. ² S-10 EL has space-saver spare tire T135/80D-15. ³ S-10 EL's space-saver tire is mounted on a 15" x 4" wheel.

ENGINE SPECS

Displacement - Liters (cu. in.)	2.5 (151) L4	2.8 (173) V6 ¹	4.3 (262) V6 ¹
Engine Ordering Code	L38	LL2 ²	LB4
Bore & Stroke (in.)	4.00 x 3.00	3.50 x 2.99	4.00 x 3.48
Compression Ratio	8.3 to 1	8.9 to 1	9.3 to 1
SAE Net Horsepower @ RPM	105 @ 4800	125 @ 4800	160 @ 4000
SAE Net Torque (lb.-ft.) @ RPM	135 @ 3200	150 @ 2400	230 @ 2800

¹ Not available in S-10 EL model. ² Produced in U.S., Canada and Mexico.

POWER TEAMS

	2WD		4x4		
	S-10 EL Pickup	S-10 Pickup	Maxi-Cab	S-10 Pickup	Maxi-Cab
2.5 (151) L4 Engine	■	■	■	N/A	N/A
2.8 (173) V6 Engine	N/A	●	●	N/A	N/A
4.3 (262) V6 Engine	N/A	●	●	■	■
5-Speed Manual Transmission w/OD	■	■	■	■	■
4-Speed Automatic Transmission w/OD ¹	N/A	●	●	●	●

■ - Standard. ● - Optional. N/A - Not Available. ¹ Not available with 2.8 (173) V6 engine.

MISCELLANEOUS DIMENSIONS (in.)

Width at top of box, front	55.3
Width at top of box, rear	54.6
Depth of cargo box	15.8

NOTE: Dimensions of Maxi-Cab short-box and Regular-Cab short-box are identical.

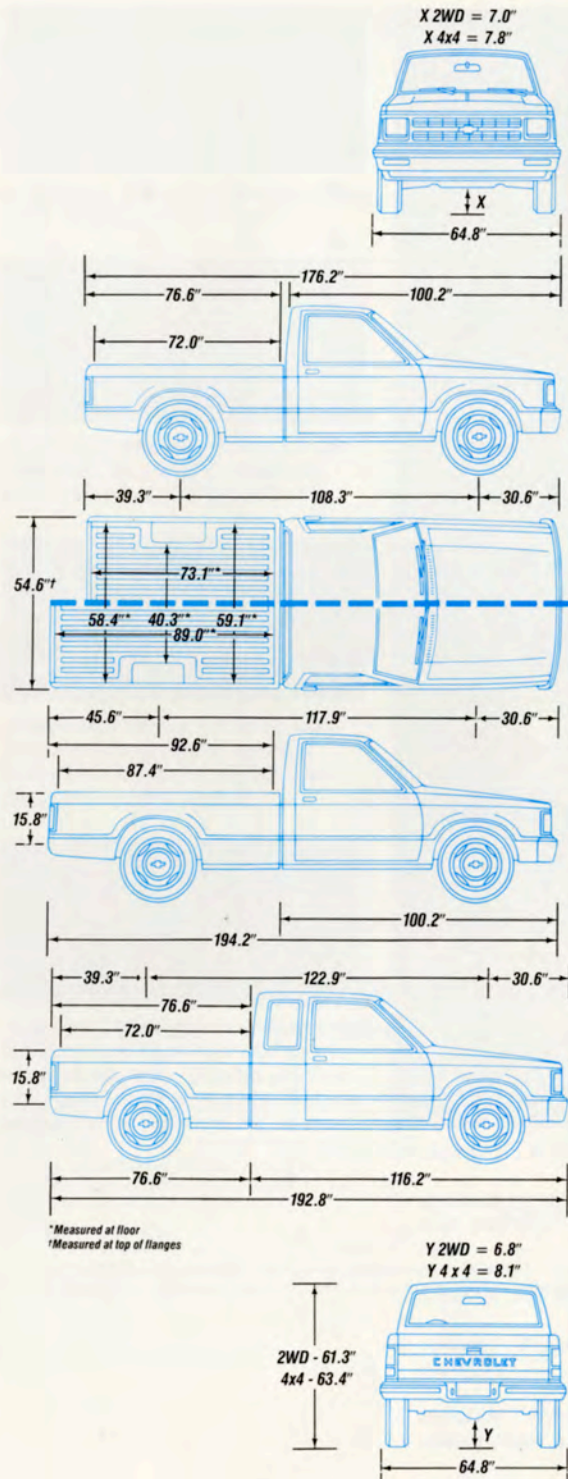

S-10 COMPACT PICKUP SPECS / TRAILERING

(Recommended Equipment in Black, Required Equipment in Red)

TRAILERING EQUIPMENT

Trailer Classification	Light		Medium		Heavy	
Maximum Gross Trailer Weight (lbs.) ¹	2000		4000		6000	5500 ²
Maximum Tongue Load	200		500		750	700
Chevy Truck Series	2WD S-10	4X4 S-10	2WD S-10	4X4 S-10	2WD S-10	4X4 S-10
HITCHES & WIRING						
Trailer Special Package	N/A	N/A	Z82	Z82	Z82	Z82
Deadweight Hitch - Rear-Step Bumper	VF6	VF6	N/A	N/A	N/A	N/A
5-Wire Wiring Harness	U89	U89	N/A	N/A	N/A	N/A
ENGINES						
Minimum Engine						
Std. 2.5L (151) 4-cyl. engine w/EFI	L38	N/A	N/A	N/A	N/A	N/A
Opt. 4.3L (262) V6 w/EFI ³	N/A	LB4	LB4	LB4	LB4	LB4
AXLES						
Minimum Rear Axle Ratio (to 1)	3.73	3.08	3.08	3.08	3.08 (5000)	3.08 (4500)
					3.42 (6000)	3.42 (5500)
OTHER OPTIONS						
Engine Oil Cooler/Heavy-Duty Radiator	N/A	Opt.	KC4	KC4	KC4	KC4
Transmission Oil Cooler/Heavy-Duty Radiator	N/A	Opt.	V02	V02	V02	V02
Heavy-Duty Radiator	V01	V01	N/A	N/A	N/A	N/A
Below Eycline Outside Rearview Mirrors	Opt.	Opt.	D44	D44	D44	D44
Heavy-Duty Shock Absorbers, Front and Rear	Opt.	Opt.	F51	F51	F51	F51
Electronic Speed Control	Opt.	Opt.	K34	K34	K34	K34
Power Steering	Opt.	Std.	N40	Std.	N40	Std.

¹ Maximum gross trailer weight includes all passengers and cargo in the S-10 Pickup plus any cargo in the trailer. If you order more than the minimum required equipment or carry more than two passengers, the additional weight must be subtracted from the maximum gross trailer weight. ² Gross trailer weight is reduced by 1000 lbs. if P235/75R-15 tires are used. ³ Standard on 4x4 models.

NOTES: (1) Model and driveline combinations must be verified by your local Chevy truck dealer for correct emissions equipment. (2) Trailering packages and most trailering options are not available with S-10 EL model, or Baja optional appearance package.

TRAILERING SPECIAL PACKAGES

If you intend to tow a light trailer (up to 2000 lbs. gross weight) with your new S-10 Pickup, an optional Trailering Special Package is not required. However, an optional heavy-duty radiator, rear step bumper and light-duty 5-wire wiring harness are required. The rear step bumper also requires the installation of a 1-7/8"-diameter hitch ball, available as an accessory. The 5-wire harness (RPO U89) includes a heavy-duty flasher, plus a male-female connector and pigtail that must be spliced into the trailer wiring harness. This allows the S-10's electrical system to activate your trailer lights and other electrical systems.

If you intend to tow a medium trailer (up to 4000 lbs. gross weight) or heavy trailer (up to 6000 lbs. gross weight), a *Heavy-Duty Trailering Special Package*, RPO

Z82, is a required option. (This Z82 option is also required, regardless of gross trailer weight, if your trailer tongue weight exceeds 400 lbs.) RPO Z82 includes a weight-distributing platform hitch receiver which is bolted to the S-10's undercarriage, and a heavy-duty 7-wire harness must be spliced to your trailer wiring harness connector.

Note that, although the S-10 Pickup can be purchased with manual transmissions, Chevrolet strongly recommends using the 4-speed automatic transmission for towing.

If you prefer to use Gross Combination Weight Ratings (GCWRs) to determine the engine, transmission and rear axle ratio you will require for towing, see the GCWR chart (which covers manual and automatic transmissions) on page 63.



▲ Chevy C2500 Pickup in Crimson Red Metallic with luxury-level Silverado trim.

The best-engineered, best-built pickups in Chevrolet history.



Sportside Short-Box.



Extended-Cab Fleetside Long-Box.



Fleetside Short-Box.



Regular Chassis-Cab.



Fleetside Long-Box.



Extended-Cab Chassis-Cab.



Extended-Cab Fleetside Short-Box.



Regular Chassis-Cab with Straight Frame Rails.

CONTENTS

Cheyenne & W/T1500.....	22	Colors / Specs.....	44
Scottsdale.....	24	Specs / Engines.....	46
Silverado.....	26	Trailerling.....	48
Sport / Sportside.....	28		
454 SS.....	30		
Special Features.....	32		
Extended-Cab.....	34		
Special Applications.....	36		
Chassis-Cab.....	38		
Standards.....	40		
Options.....	42		



▲ Cheyenne interior in Blue.

◀ W/T1500 Work Truck in Summit White.

▼ K2500 Cheyenne long-wheelbase Fleetside in Brilliant Blue Metallic.



Chevy's most affordable full-size pickups.

The W/T1500 Work Truck is designed for those who want a hardworking full-size pickup with a distinctly affordable price tag. Available only as a 1500 (1/2-ton) Series Regular Cab with long cargo box (8-ft.), the W/T1500 comes as either a 2WD (C) or 4x4 (K) model. It offers somewhat fewer amenities and options than the standard C/K models, but the same powertrain and a considerably lower Manufacturer's Suggested Retail Price. Chevy's W/T1500 Work Truck is equipped with a standard 4.3-liter (262 cu. in.) Vortec V6 engine with Electronic Fuel

Injection, linked to a 5-speed manual transmission with overdrive. It has a maximum payload rating of up to 1870 lbs. (Payload includes passengers, equipment and cargo.)

The Cheyenne is the standard Chevy—and the 1/2-ton 2WD Cheyenne is Chevy's next-most-affordable full-size pickup. Cheyenne comes in 1/2-, 3/4- and 1-ton versions (designated the 1500, 2500 and 3500 Series), with a wide choice of payload and towing capacities.

Like the W/T1500, it is available as either a 2WD or 4x4 model. And, unlike the W/T1500, Cheyenne offers you

a wide selection of appearance, convenience and performance options.

Both the W/T1500 and Cheyenne feature easy entry, easy exit and room for three across on a big, wide, foam-cushioned, all-vinyl bench seat with folding backrest. Both trucks also feature standard power steering, standard power front disc/rear drum brakes, a rear-wheel anti-lock brake system (operates in 2WD mode only) and standard all-season steel-belted radial tires.

▼ *Scottsdale Custom Vinyl interior in Saddle with 60/40 split bench seat.*



A major move up in style and luxury.

The optional mid-level Scottsdale trim is an appealing dress-up look for a tough, all-around pickup. It comes with all Cheyenne trim items plus the following exterior enhancements: Deluxe Front Appearance Package (dark argent grille with bright trim and rectangular composite halogen headlamps); Rally Wheels (not available with Big Dooley option); black body-side and wheel-opening moldings (except K3500 Series and Sportside); chrome front bumper with black rub strip; and black applique with "Chevrolet" lettering on the tailgate.



▲ *K1500 Long-Box in Flame Red with Scottsdale trim.*

Scottsdale interior touches include: standard cloth bench seat with folding seat-back (a Custom Vinyl seat is optional at no extra cost); Custom steering wheel; extra in-cab insulation; grained interior door panels with soft-vinyl upper trim, integral armrests, map pockets and "Scottsdale" identification; color-keyed rubber floor covering; and a full-length cloth headliner.



***Classic luxury
in a classically
styled pickup.***

The luxury-level Silverado trim makes any Chevy Full-Size Pickup something really special—with many of the touches you'd expect in a luxury sedan. Shown here with Chevy's distinctive Sportside model (detailed on page 29), the Silverado trim includes all Scottsdale trim items plus the following exterior refinements: Deluxe bright-accented rub strip on the chromed front bumper; bright wheel-opening moldings (on Fleetside models) and bright-accented body-side moldings; swing-out rear-quarter windows (on Extended-Cab models); Deluxe tailgate trim with "Chevrolet" letters over bright aluminum applique; and an exclusive "Chevrolet" tailgate insert (shown above) on Sportside models.

Silverado interior highlights include: a Custom Vinyl seat (Custom Cloth seat trim available at no extra cost, and includes fold-down center armrest). A special process—formed seat construction—bonds the Silverado's seat frame, foam cushion and trim material to provide a stylish seat contoured to the human body. Other niceties inside the Silverado include: an electronically tuned AM/FM stereo radio with seek and scan and digital clock; color-keyed carpeting; soft-vinyl Two-Tone door trim panels with integral armrests, map pockets and "Silverado" identification; and a color-keyed cloth headliner.

The Silverado trim level is not available with the C3500 HD Chassis-Cab.



▲ Regular-Cab Custom Cloth interior in Beige with optional Silverado trim.

◀ K1500 Regular-Cab Sportside Pickup in Summit White with optional Silverado trim.



▲ C1500 Sportside in Smoke Blue Metallic with optional Silverado trim.

◀ In background: 4x4 K1500 Fleetside in Onyx Black with optional Sport Appearance Package and optional Silverado trim. In foreground: 2WD C1500 Fleetside in Flame Red with optional Sport Appearance Package and optional Silverado trim.

They don't look like "all work and no play," do they?

Two of them (the Flame Red half-ton 2WD and Onyx Black half-ton 4x4) have an optional Sport Appearance Package that's available on C/K1500 models with Scottsdale or Silverado trim. It's designed specifically to give styling distinction to Short-Box Chevy Fleetsides.

Interestingly enough, it was a Chevy Sport, fitted with required safety equipment, that averaged 103 miles per hour for 24 hours at Indy, broke an Indy endurance record and won the Hulman Indy Challenge Trophy.

"Sport truck" items for the 2WD include a black grille, side and rear "Sport" graphics, chrome-plated wheels, halogen composite headlamps, body-color front and rear bumpers (rear bumper has rub strip and step pad), special

body-side moldings with red accents and black outside rearview mirrors. An additional option for 2WD models, the Sport Handling Package, has special springs and Bilstein gas shocks. (This package requires B.F. Goodrich T/A® P275/60R-15 blackwall tires.)

The Sport Appearance Package for 4x4s includes a black grille, side and rear "4x4" graphics, cast-aluminum wheels, halogen composite headlamps, black front and rear bumpers (rear bumper has step pad), and black outside rearview mirrors.

To take your K1500 Sport 4x4 one exciting step further, order the optional "Z71" Off-Road Package with skid plate, Bilstein high-pressure gas shocks and "Z71" graphics on the pickup box sides. (The Z71 package requires optional LT265/75R-16C tires.)

The third truck shown here — a Sportside 2WD in Smoke Blue Metallic — is the only Chevy Full-Size Pickup to offer classic stepside styling. Its cargo-box outer side panels are fiberglass, and each fender is flanked front and rear by functional steps to aid in loading and unloading. Sportside is available as either a 2WD or 4x4 1500 Series Short-Box and can be ordered with any trim level: Cheyenne, Scottsdale or Silverado.



▲ 454 SS Custom Cloth interior in Garnet Red, with high-back bucket seats and center console.



▲ C1500 Short-Box 454 SS with Silverado trim in Onyx Black.

Are you ready for this much truck?

It's a one-of-a-kind C1500 Regular-Cab Short-Box model with the heart of a lion.

The 454 SS has the largest V8 in a regular-production half-ton pickup: an improved 7.4 Liter (454 Cu. In.) gas V8 with 255 net HP at 4000 RPM, and 405 lb.-ft. of net torque at 2400 RPM. This formidable powerplant is linked to a new-for-'91 4-speed automatic overdrive transmission. Other performance hardware includes a Performance Handling Package, locking rear differential with 4.10 axle ratio and Bilstein gas shocks.

454 SS *looks* the part, too. It's Onyx Black, rides on special-production B.F. Goodrich T/A® P275/60R-15 black-wall tires, lights its way with halogen composite headlamps, and features luxury-level Silverado trim with

special blackout effects, plus tinted glass.

The Silverado trim continues inside, along with a lot of other appointments guaranteed to please the driver. Standard 454 SS interior features include: a special plush Garnet Red cloth interior; special high-back reclining sport bucket seats; center console; a Driver Convenience Group, consisting of electronic speed control and Comfortilt 4-spoke Sport steering wheel; an electronically tuned AM/FM stereo radio with cassette player, clock and graphic equalizer; air conditioning; a sliding rear window; an Operating Convenience Group consisting of power door locks and power windows; a gage cluster with tachometer; color-keyed floor mats; an auxiliary lighting package; and, for good measure, intermittent windshield wipers.

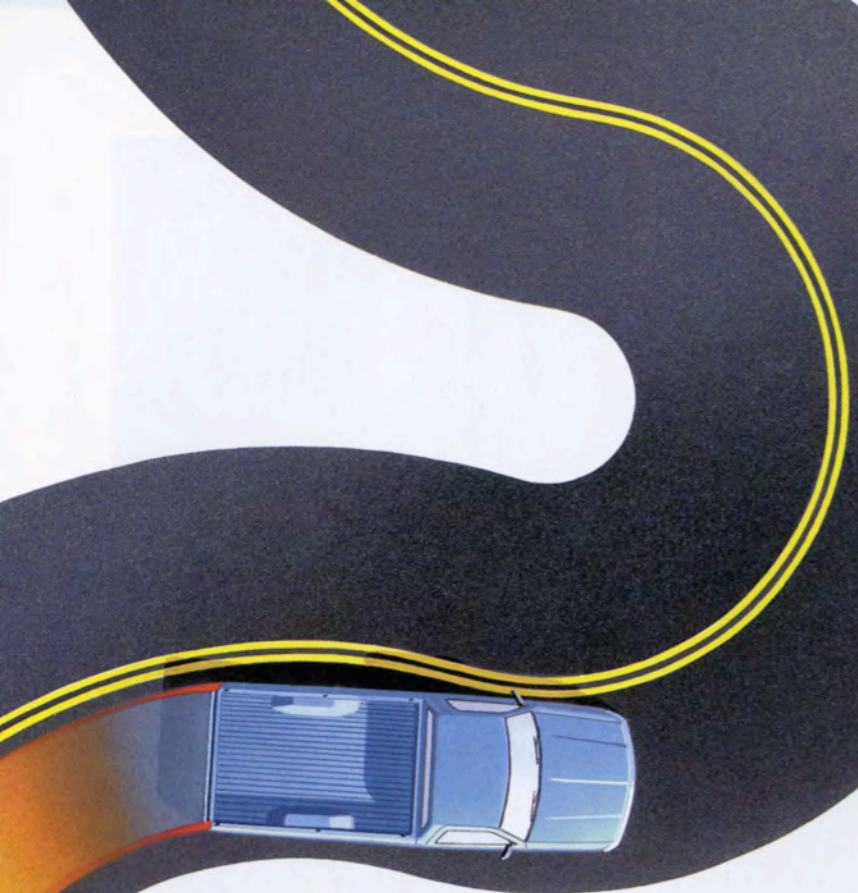

▲ C/K's standard rear-wheel anti-lock brake system assists the driver during high-deceleration braking conditions, whether the driver is braking the vehicle on a straight road or on a curve, with or without a load. (Operates in 2WD mode only.)

Take the wheel and you take charge.

It's a real feeling of "command." And it begins with the power under your right foot. The Chevy C/K line offers an impressive selection of gasoline- and diesel-powered models. There's an improved 7.4-liter (454 cu. in.) gasoline V8 engine for all 3500 Series and selected 2500 Series applications – and for the 454 SS Pickup. Other powertrain improvements for 1991 include a new starter motor, internal improvements in the 5.0 and 5.7 Liter V8 engines and an improved throttle body fuel injection unit. A new-for-'91 optional heavy-duty 4-speed automatic overdrive transmission replaces the 3-speed automatic in the H.D. 2500 and 3500 Series.

Standard in every C/K in '91 is a rear-wheel anti-lock brake system (operates in 2WD mode only). The system features a computer and a sensor in the transmission that are designed to monitor rear-wheel speed. When the computer detects impending rear-wheel lockup, the system automatically modulates the rear brake pressure as necessary to minimize rear-wheel lockup.

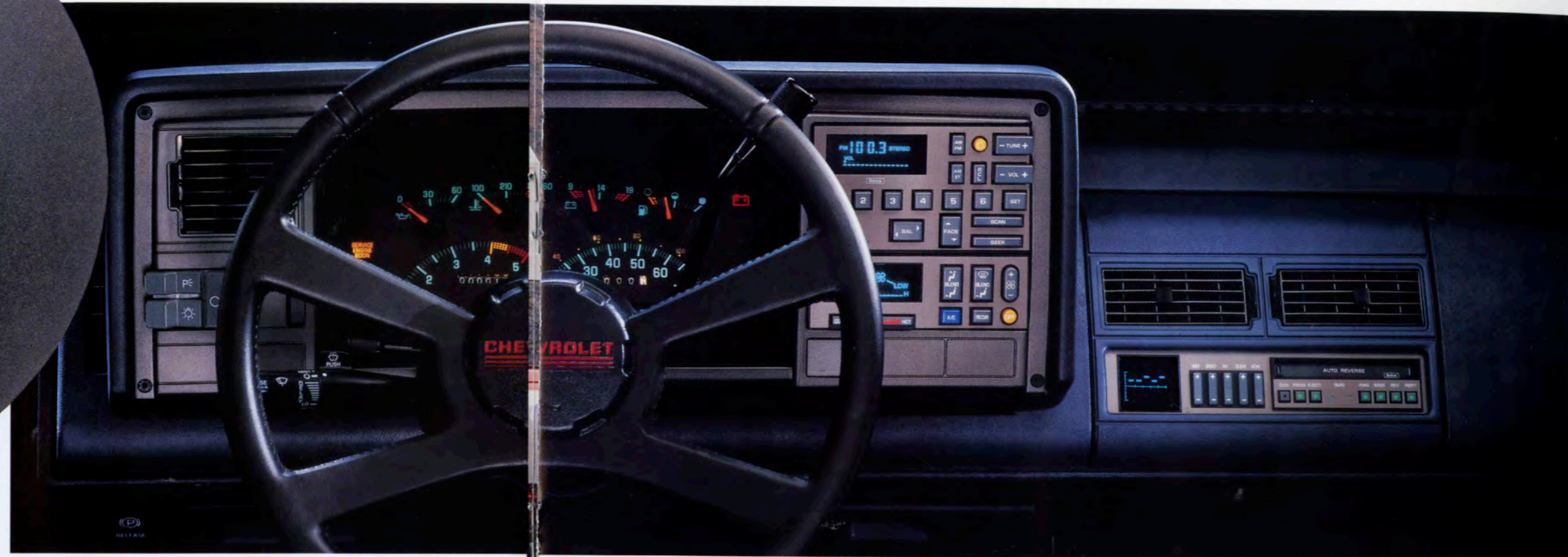

▲ The Silverado instrument panel, shown here with selected options (including a new-for-1991 tachometer), places all gauges for maximum visibility and positions controls within easy reach.

▼ The Insta-Trac shifter in every K-Series 4x4 Chevy Full-Size Pickup is mounted in a lighted console that informs the driver at a glance which drive mode the vehicle is operating in.



Chevy 4x4 models have a standard "shift-on-the-fly" Insta-Trac 4x4 system that allows you to shift in and out of 4-wheel drive without stopping or backing up. They also feature a torsion-bar independent front suspension that delivers excellent tire-to-terrain traction, high ground clearance and easy-riding comfort.



▲ Quick proof that Chevy Full-Size Pickups are built to take it: The race-modified "American Thunder" C1500, that Frank "Scoop" Vessels piloted to a Class 8 victory in the 1989 SCORE/HDRA Off-Road World Championship.



▲ Extended-Cab interior in Blue with optional Silverado trim.

A little bit longer, a lot roomier.

Chevy Extended-Cab Pickups are only 24 inches longer than Regular-Cab models, but they deliver much more in-cab space for passengers and cargo.

Standard seating in the Extended-Cab is a three-passenger front bench seat in vinyl with a forward-folding backrest. The optional rear seat is a true, full-width, forward-facing bench for three additional passengers. Leg room for rear-seat passengers is a comfortable 32.1 inches.



▲ In foreground: K2500 Short-Box Extended-Cab in Brilliant Blue Metallic with optional Scottsdale trim.
 ▲ In background: K3500 Long-Box Extended-Cab with optional dual rear wheels, Silverado trim and Deluxe Two-Tone in Catalina Blue Metallic and Quicksilver Metallic.

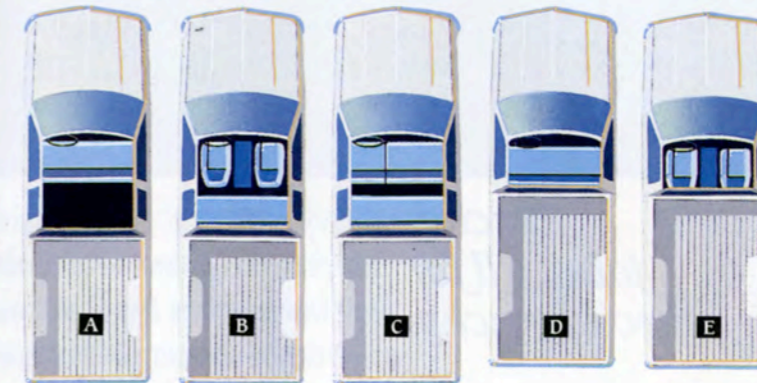

◀ C/K SEATING POSSIBILITIES
 A. Standard three passenger seating in Extended-Cab, with 40.5 cu. ft. of in-cab storage space.
 B. Optional 5-passenger seating in Extended-Cab with front bucket seats and forward-facing rear bench seat.
 C. Optional 6-passenger seating in Extended-Cab with forward-facing rear seat bench. (Rear bench folds to create in-cab storage space.)
 D. Standard 3-passenger seating in Regular-Cab. (Bench seat folds forward for access to generous in-cab storage space.)
 E. Optional 2-passenger seating in Regular-Cab, with front bucket seats.

And the back section of the cab roof doesn't slope forward, so plenty of head room is assured.

There is plenty of room for secure storage in the cab with the optional rear seat folded, and space for up to 40.5 cu. ft. of gear without the optional rear seat. The Extended-Cab is available as a 2WD or 4x4, Short-Box or Long-Box, with a wide selection of payloads and with either single or dual rear wheels.



Special jobs call for special trucks.

Chevy Full-Size Pickups are hard workers that readily adapt to a wide range of special jobs. A case in point is the Big Dooley. This optional feature provides dual rear wheels on C/K3500 Series Pickups. A properly equipped Big Dooley with standard 5.7-liter (350 cu. in.) gas V8 engine can have a payload as high as 5038 lbs., including passengers, equipment and cargo. The towing story is strong, too: a properly equipped Big Dooley can move up to 19,000 lbs., including vehicle, trailer, passengers, cargo and equipment.



▲ C2500 Fleetside Pickups can be equipped with a special pickup-box hoist to serve as a versatile dump truck. Hoist is available from outside manufacturers.

▶ A properly equipped Chevy 4x4 can be outfitted for especially demanding jobs like snowplowing. The snowplow is available from outside manufacturers.

◀ C3500 Series Pickup with Big Dooley option and Deluxe Two-Tone in Crimson Red Metallic and Quicksilver Metallic.



The standard C/K Full-Size Chevy Pickup is a hard worker in its own right. With plenty of power for the job at hand, it can be adapted for a wide range of special applications including fifth-wheel trailers, snowplows, winches, dump bodies and more. In addition, there are indentations in the sidewalls of all Fleetside cargo boxes that allow you to build a platform of 2x6's across the top of the wheel-housings and double-deck your loads.



Straight-rail Chassis-Cabs with GVWRs up to 15,000 lbs.

In 1991 a new C3500 HD (Heavy-Duty) Chassis-Cab with straight rails and a GVW Rating of 15,000 lbs. joins the Chevy lineup. This new straight-rail Chassis-Cab offers a standard 5.7 Liter V8 or optional 7.4 Liter V8 and the choice of 4-speed automatic or 5-speed manual transmission. This new 2WD model features dual rear wheels with low-profile tires and four-wheel disc brakes. It also has a solid I-beam front axle with a 5000-lb.-capacity, plus leaf springs. The cab interior, grille and bumpers are the same as for the rest of the C/K Pickup line.

This new model joins two other dual-rear-wheel, straight-rail C/K Chassis-Cabs. All of them feature parallel, flat-top frame rails and 34" spacing for ready installation of van, dump, stake, utility and many other types of commercial bodies.

Rounding out the C/K Chassis-Cab lineup are the C/K2500 and C/K3500 Series models with single or dual rear wheels (3500 only) and the same tapered frame as the C/K Full-Size Pickup models.

▼ The new C3500 HD Chassis-Cab with 15,000-lb. GVWR is available in three models: a 135.5" wheelbase with a 60" cab-to-axle, a 159.5" wheelbase with an 84" cab-to-axle and a 183.5" wheelbase with a 108" cab-to-axle. Two engines are available: the 5.7 Liter V8 and the 7.4 Liter V8.

The standard C/K3500 Series Chassis-Cab models with straight rails are available with a 135.5" wheelbase and 60" cab-to-axle as well as 159.5" wheelbase and 84" cab-to-axle. Two rear axle widths are available: a standard 84.1" width, outside to outside, and an optional "wide track" width of 91.0"

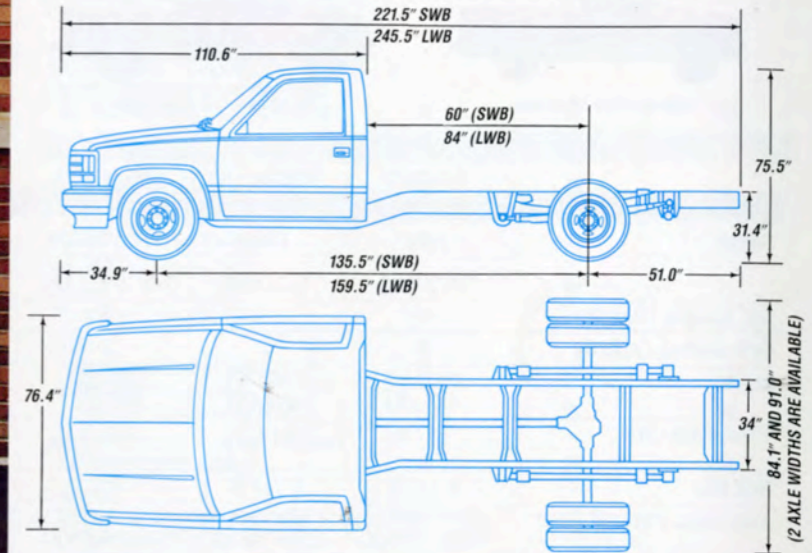

▲ New C3500 HD Chassis-Cab in Summit White with straight rails for easy mounting of special bodies. Shown here with retriever body from independent supplier.

▼ C3500 Chassis-Cab in Sandstone Metallic with utility body. A wide selection of specialized body equipment is available from various independent suppliers.



▼ C/K2500 and C/K3500 Series Chassis-Cabs with single or dual rear wheels (3500 only) and the same tapered frame as the C/K Full-Size Pickup models.

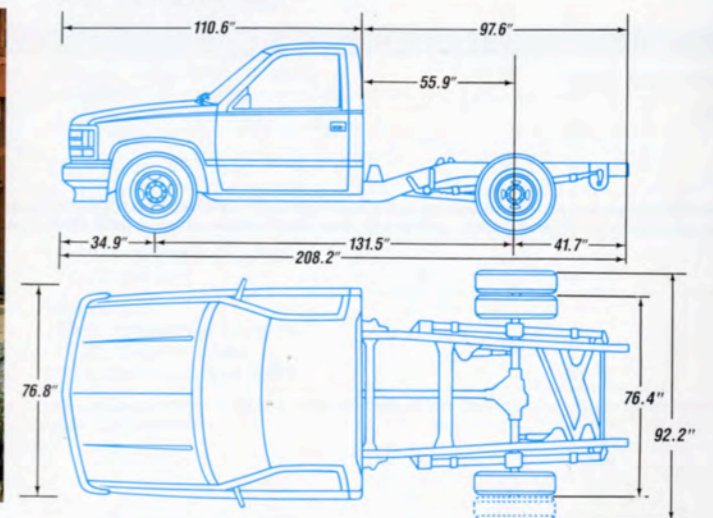

MODEL SELECTOR



Sportside Regular-Cab.



Regular-Cab Long-Box.

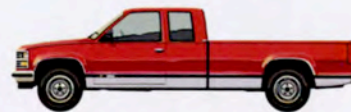

Extended-Cab Long-Box.



Regular Chassis-Cab.



Regular-Cab Short-Box.

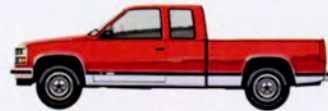

Extended-Cab Short-Box.



Regular Chassis-Cab.



Extended Chassis-Cab.

MODEL SELECTOR	Sportside Short-Box	Regular-Cab Short-Box	Regular-Cab Long-Box	Extended-Cab Short-Box	Extended-Cab Long-Box	Regular Chassis-Cab	Regular Chassis-Cab	Extended Chassis-Cab
Series	1500 (1/2 ton)	1500 (1/2 ton)	1500/2500/ 3500 (1/2, 3/4, 1 ton)	1500/2500 (1/2, 3/4 ton)	1500/2500/ 3500 (1/2, 3/4, 1 ton)	3500 (1 ton)	3500 HD (1 ton)	3500 (1 ton)
Std. Seating Capacity	3	3	3	3	3	3	3	3
Opt. Seating Capacity	2	2	2	5,6	5,6	2	—	5,6
Drives	2WD (C) 4x4 (K)	2WD (C) 4x4 (K)	2WD (C) 4x4 (K)	2WD (C) 4x4 (K)	2WD (C) 4x4 (K)	2WD (C) 4x4 (K)	2WD (C)	2WD (C) 4x4 (K)
Wheelbase (in.)	117.5	117.5	131.5	141.5	155.5	131.5, 135.5 159.5	135.5, 159.5 183.5	155.5
Box Size	6 1/2 ft.	6 1/2 ft.	8 ft.	6 1/2 ft.	8 ft.	—	—	—
Min./Max. Payload (lbs.) ¹	1380/1870(C) 1350/1945(K)	1389/1878(C) 1350/1953(K)	1592/5038(C) 1212/4883(K)	2196/2961(C) 1623/2657(K)	1856/4782(C) 1476/4604(K)	4080/6275(C) 3723/6915(K)	9188/9438(C)	3824/5200(C) 3444/5021(K)
Min./Max. GCW (lbs.) ²	8500/12,500	8500/14,500	8500/19,000	8500/15,000	8500/19,000	13,500/19,000	15,000	13,500/19,000

TRIM LEVELS	Cheyenne ³ (N/A 454 SS)	Scottsdale ³ (N/A 454 SS)	Silverado (N/A 3500 HD)
Fabrics	Standard vinyl; optional cloth.	Standard cloth; optional Custom Vinyl.	Custom Vinyl or Custom Cloth.
Interior Colors ⁴	Blue, Garnet Red and Saddle available in all pickups; Beige and Gray available in Regular-Cab only with standard cloth or vinyl bench seat.	Blue, Garnet Red and Saddle available in all pickups; Beige and Gray available in Regular-Cab only.	Blue, Garnet Red and Saddle available in all pickups; with bench or bucket seats; Beige and Gray available in Regular-Cab only with bench seats.

SPECIAL MODELS & PACKAGES	
W/T1500 Work Truck	(See page 22.)
Sportside	(See page 28.)
Sport	(See page 28.)
454 SS	(See page 30.)

¹ Payload includes passengers and cargo. Payloads indicated are for gasoline engines only. ² GCW (Gross Combined Weight) includes vehicle, trailer, people, and equipment. GCWs are for gasoline-engine models only. ³ C3500 HD available in Saddle and Gray only. ⁴ Your choice of exterior color will determine your choice of interior color. Not all interior colors are available with all trim levels. See your Chevy truck dealer for details.

TRIM FEATURES ¹

INTERIOR	Cheyenne	Scottsdale	Silverado
Floor Covering			
Front embossed black rubber mat (also rear mat in Extended-Cab)	■	—	—
Color-keyed rubber mat	—	■	—
Color-keyed carpeting	—	—	■
Glass: Tinted, all windows	■	■	■
Headliner			
Vinyl	■	—	—
Full-length, color-keyed cloth	—	■	■
Insulation and Sound-Deadening Materials:			
On dash panel and under floor mats	■	■	■
Additional to standard	—	—	■
Lights: Instrument cluster and cab interior; shift point indicator light with manual transmission and gas engine	■	■	■
Mirror: 10" day/night rearview	■	■	■
Rear-Quarter Windows: Swing-out (in Extended-Cab only)	—	—	■
Storage Tray: Covered	—	■	■
Tools: Mechanical jack and wheel wrench	■	■	■
Windshield Wipers/Washer (pulse)	■	■	■
INSTRUMENT PANEL / STEERING COLUMN			
Cigarette Lighter	■	■	■
Gages: Speedometer, odometer, fuel, voltmeter, engine temperature and oil pressure	■	■	■
Heater and Defogger: Deluxe outside-air type with side-window defoggers	■	■	■
Hood Lock: Inside release	■	■	■
Steering Column: Energy-absorbing	■	■	■
Steering Wheel: Custom	■	■	■
Stowage Box (RH Side): With beverage holder	■	■	■
Switches: Interior, exterior and instrument panel lights, heater fan: on instrument panel; directional signals, headlamp high/low beam, windshield wipers/washers and hazard warning; on steering column. Key-in-ignition warning buzzer	■	■	■
Warning Lights: Safety belt, service/parking brake, direction/hazard signal and high beams	■	■	■
DOOR PANELS			
Map Pockets	—	■	■
Painted Areas: Same color as primary exterior color, trim color same as seat trim	■	■	—
Trim Panels			
Color-keyed molded plastic with integral armrests	■	■	—
Two-tone soft vinyl with closing assist straps	—	—	■

	Cheyenne	Scottsdale	Silverado
SEATING			
Bench Seat			
Foam-cushioned all-vinyl with folding backrest	■	—	—
Foam-cushioned cloth with folding backrest (Custom Vinyl in Extended-Cab)	—	■	—
Foam-cushioned Custom Vinyl or Custom Cloth	—	—	■
Safety Belts: All seating positions, with lap/shoulder belts at all outboard seating positions	■	■	■
EXTERIOR ¹			
Body-Side Moldings: Black ²	—	■	—
Bright-accented ²	—	—	■
Bumper: Front, chromed	■	■	■
Bumper Rub Strip			
Front	—	■	—
Front with bright accent	—	—	■
Grille			
Argent molded plastic	■	—	—
Dark argent molded plastic with chrome trim	—	■	■
Mirrors: Below Eyeline, RH and LH black adjustable	■	■	■
Tailgate			
Removable, with outlined embossed "Chevrolet" lettering ²	■	—	—
Removable with black applique and "Chevrolet" block lettering ²	—	■	—
Removable with "Chevrolet" lettering over bright aluminum applique ²	—	—	■
Tow Hooks (4x4 models only)	■	■	■
Wheels			
Silver with black plastic hubcaps	■	—	—
Rally (except dual-rear wheel models) ²	—	■	■
Wheel Opening Moldings: Black (except on Sportside models, K2500/C6P models, and models with dual rear wheels) ²	—	■	—
EXTERIOR LIGHTING			
Backup Lamps: Integral with tail lamps	■	■	■
Directional/Parking Lamps: Front and rear	■	■	■
Headlamps			
Two, rectangular halogen	■	—	—
Four, composite with replaceable halogen bulbs	—	■	■

¹ Not applicable for W/T1500, 454 SS or C3500 HD models. See your Chevy truck dealer for trim information on these trucks.
² Except Chassis-Cab models.

PREFERRED EQUIPMENT GROUPS

TRIM LEVELS	Cheyenne	Scottsdale	Silverado
GROUP 1			
Body: Fleetside	■	■	■
GROUP 2			
Lighting: Auxiliary		■	■
Wheel Covers ¹		■	■
Window: Sliding rear or rear-window defogger		■	■
GROUP 3			
Scottsdale Trim Level		■	■
Radio: ETR AM/FM stereo w/seek-scan and digital clock ¹		■	■
GROUP 4			
Silverado Trim Level			■
Air Conditioning			■
Mirrors: Exterior, Below Eyeline, stainless steel ¹			■
Driver Convenience Group: Comfortilt steering wheel and electronic speed control			■
Seat: Rear, folding (Extended-Cab only)			■
GROUP 5			
Operating Convenience Group: Power door locks and power windows			■
Radio: ETR AM stereo ² /FM stereo w/seek-scan, cassette tape player, graphic equalizer and digital clock			■

¹ Upgrade allowed. ² Receives C-Quam® AM stereo broadcasts. Most AM stereo stations across the country broadcast in C-Quam, but some do not. Check with your local stations for compatibility in your area.

These convenient option packages make it easy to tailor the C/K Pickup to your exact specifications and can save you money. You would pay appreciably more buying all the options in a Preferred Equipment Group as individual options. (Savings based on comparison of Manufacturer's Suggested Retail Price of option packages versus M.S.R.P. of individual options purchased separately.) See your dealer for Preferred Equipment Groups for W/T1500, 454 SS, Sport pickup and Chassis-Cabs.

MANUAL TRANSMISSION BONUS PACKAGE

If you order your 1991 C/K Series Full-Size Pickup with Preferred Equipment Group 2, 3, 4 or 5 and a manual transmission, you may select one of the special option groups listed below at no extra charge.

Heavy-Duty Package • 5.0 Liter (305 Cu. In.) V8 (1500 Series only, upgrade allowed) • Auxiliary lighting • Engine oil cooler • ETR AM/FM stereo radio with premium dual rear speakers, seek and scan, stereo cassette player and digital clock (1500 and 2500 Series only) • Heavy-duty chassis (1500 Series only) • P235/75R-15 blackwall tires (1500 Series only) • Skid plate (4x4 models only) • Stainless steel mirrors.

Appearance Package • Cast-aluminum wheels (1500 Series only) • Chrome rear step bumper (painted step bumper with standard decor) • Deluxe Two-Tone paint • ETR AM/FM stereo radio with premium dual rear speakers, seek and scan, stereo cassette tape player and digital clock • Sliding rear window • Stainless steel mirrors • Wheel covers (3500 Series with single rear wheels only).

Convenience Package • Air conditioning • Driver Convenience Group: Comfortilt steering wheel and electronic speed control (1500 Series only) • ETR AM/FM stereo radio with premium dual rear speakers, seek and scan and digital clock (1500 and 2500 Series only).

INDIVIDUALLY AVAILABLE OPTIONS.

(May be added to any Preferred Equipment Group if not already included.)

TRIM LEVELS	Cheyenne	Scottsdale	Silverado
Air Conditioning	■	■	■
Auxiliary Lighting	■	■	●
Batteries: Auxiliary (gasoline models only)	■	■	■
Bedliner (Fleetside models only)	■	■	■
Cargo Area Lamp	■	■	■
Cold Climate Package (incl. engine block heater and coolant protection)	■	■	■
Dome and Reading Light	■	■	●
Driver Convenience Group: Comfortilt steering wheel and electronic speed control	■	■	■
Folding Rear Seat (Extended-Cab only)	■	■	●
Fuel Filler Cap: Locking	■	■	■
Gage Package w/Tachometer	■	■	■
Glass: Deep-tinted (Extended-Cab only)	■	■	■
Mirrors: Outside rearview Below-Eyeline, stainless steel Camper, stainless steel	■	■	■
Operating Convenience Group: Power door locks and power windows	■	■	■
Rear Axle Locking Differential	■	■	■
Rear-Window Defogger (N/A with sliding rear window)	NA	■	■
Roof Marker Lights: Five	■	■	■
Sliding Rear Window	■	■	■
Skid Plate: Off-road (4x4 models)	■	■	■
Steering Wheels			
Comfortilt (available only with electronic speed control)	■	■	■
Sport	■	■	■
Swing-Out Rear-Quarter Windows (Extended-Cab only)	■	■	■
Tow Hooks (std. on 4x4)	■	■	■
Z71 Sport Handling Package (4x4 only)	■	■	■

■ - Optional, ● - Included, N/A - Not Available.

► The special high-back reclining Sport bucket seats that are standard in the 454 SS are a new-for-'91 option in many other C/K Regular-Cab Pickups. They're available in Custom Cloth, in Blue, Garnet, Gray and Saddle (dependent on the buyer's choice of exterior color).



C/K FULL-SIZE PICKUP OPTIONS



▲ Standard AM radio (except in W/T1500 and 454 SS).



▲ Optional ETR AM/FM stereo radio with premium dual rear speakers, seek and scan and digital clock.



▲ Optional ETR AM/FM stereo radio with premium dual rear speakers, seek and scan, stereo cassette tape player and digital clock. Standard in 454 SS.



▲ Optional ETR AM stereo/FM stereo radio with premium dual rear speakers, seek and scan, graphic equalizer and digital clock, plus stereo cassette tape player with search and repeat.

¹Receives C-Quam[®] AM stereo broadcasts. Most AM stereo stations across the country broadcast in C-Quam, but some do not. Check with your local stations for compatibility in your area.



- A. Standard wheels with black hubcaps. "Chevrolet" emblem on 2WD and "4x4" on 4x4 models.
- B. Optional wheel covers for Cheyenne. "Chevrolet" emblem on 2WD and "4x4" on 4x4 models.
- C. Rally Wheels standard on Scottsdale and Silverado, optional on Cheyenne.
- D. Optional cast-aluminum wheels (2WD only).
- E. Optional cast-aluminum wheels (4x4 only—standard on Sport 4x4).
- F. Standard Sport 2WD wheels. Also on 454 SS with black center hubcap in place of chrome.
- G. Standard Big Dooley wheels.



◀ Optional Driver Convenience Group consists of Comfortilt steering wheel and electronic speed control. Comfortilt makes getting in and out of the driver's seat easy and also gives the driver a just-right adjustment for short trips and long ones. (Shown with Silverado Sport steering wheel.)



◀ Extended-Cab swing-out rear-side windows enhance the comfort of second-seat passengers. (Standard with Silverado trim.)



▲ A new-for-'91 optional bedliner (available with Fleetside models only) protects the C/K's cargo bed, sidewalls and inside tailgate panel from minor dents and dings during loading and unloading, and also provides additional insulation from road noise. See page 66 for additional information and warranty restrictions.



▲ Cargo-box light and rear-window defogger are but two of many available options.

INTERIOR COLORS

	Blue	Gray	Garnet	Beige	Saddle
CHEYENNE					
Vinyl Bench Seat	■	■ /	■	■ /	■
Cloth Bench Seat	■	■ /	■	■ /	■
Vinyl Split Bench Seat (Ext.-Cab only) ²	■		■		■
Cloth Split Bench Seat (Ext.-Cab only) ²	■		■		■
SCOTTSDALE					
Cloth Bench Seat	■	■ /	■	■ /	■
Custom Vinyl Bench Seat	■	■ /	■	■ /	■
Cloth Split Bench Seat (Ext.-Cab only) ²	■		■		■
Custom Vinyl Split Bench Seat ³	■		■		■
Custom Vinyl Bucket Seats ³	■		■		■
SILVERADO					
Custom Cloth Bench Seat (Reg.-Cab only)	■	■ /	■	■ /	■
Custom Vinyl Bench Seat (Reg.-Cab only)	■	■ /	■	■ /	■
Custom Vinyl Split Bench Seat ³	■		■		■
Custom Cloth Split Bench Seat ³	■		■		■
Custom Cloth Bucket Seats ³	■	■ /	■		■
Custom Vinyl Bucket Seats ³	■		■		■
Custom Cloth Reclining High-Back Bucket Seats	■ /	■ /	■ /		■ /

EXTERIOR COLORS ⁴

Onyx Black		■ /	■	■ /	■
Quicksilver Met.	■				
Catalina Blue Met.	■	■ /			
Brilliant Blue Met.	■	■ /			
Crimson Red Met.		■ /	■		
Smoke Blue Met.		■ /	■	■ /	■
Red Flame		■ /	■		■
Sandstone Met.				■ /	
Slate Met.		■ /	■		
White Summit	■	■ /	■	■ /	■

¹ Not available with Extended-Cab models. ² Includes optional folding rear seat. ³ In Extended-Cab models, includes optional folding rear seat. ⁴ Ask your Chevy truck dealer for information on Conventional, Special and Deluxe Two-Tone combinations, plus body striping. Note: (1) Two-Tone combinations are not available on all models. W/T1500, 454 SS, Sport Trucks and Chassis-Cabs are available in solid colors only. (2) Interior/ exterior color restrictions apply to C3500 HD models. See your Chevy truck dealer for details.

OPTIONAL TWO-TONES ¹

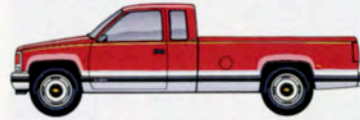

▲ *Conventional Two-Tone places the accent color below the lower styling line.*

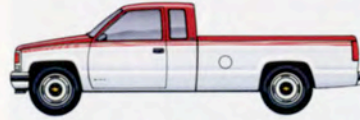

▲ *Special Two-Tone includes a multi-stripe decal at the upper styling line and the accent color below. (Not available on Sportside models.)*

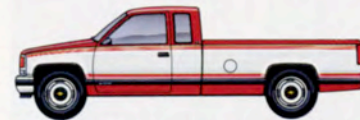

▲ *Deluxe Two-Tone features a multi-stripe decal at the upper styling line and the accent color between the decal and lower feature line. (Not available on Sportside models.)*

¹ Not available 454 SS, W/T1500, Sport truck or Chassis-Cab.

EXTERIOR COLORS

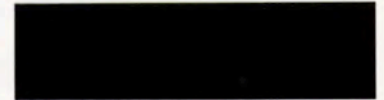

Onyx Black ^{1, 2}



Quicksilver Met. ³



Catalina Blue Met.



Brilliant Blue Met.



Crimson Red Met.



Smoke Blue Met. ³



Flame Red ^{2, 3}



Sandstone Met. ⁴



Slate Met.

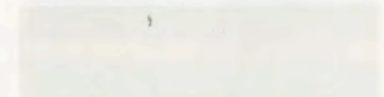

Summit White ^{2, 3}

¹ Only color available on 454 SS.

² One of the three colors available with optional Sport appearance package.

³ One of the four colors available on the W/T1500.

⁴ Not available on Extended-Cab.

Note: Colors for C3500 HD models are not included here. See your Chevy truck dealer for this information.

IMPORTANT NOTE: Aftermarket manufacturers offer many products such as slide-in campers and camper shells that are designed to fit pickup trucks. However, such products built prior to the 1988 model year may not fit on the beds of our 1988 or newer models. Please confirm the compatibility of any aftermarket product you intend to install on your new Chevy C/K Full-Size Pickup by consulting with the product manufacturer, or by checking the cargo-box dimensions indicated on page 45.

C/K FULL-SIZE PICKUP COLORS / SPECS

PAYLOADS BY SERIES

	Series	Regular-Cab			Extended-Cab		
		Wheelbase (in.)	GVWR (lbs.)	Payload Rating (lbs.) ¹	Wheelbase (in.)	GVWR (lbs.)	Payload Rating (lbs.) ¹
Two-Wheel-Drive Pickups	C1500	117.5	5600	1878	141.5	6200	2315
	C1500	131.5	5600/6100	1711/2192	155.5	6200	1975
	C2500	—	—	—	141.5	7200	2961
	C2500	131.5	7200/8600	3144/4111	155.5	7200/8600	2868/3835
	C3500	131.5 ²	10,000	5038	155.5 ²	10,000	4782
Two-Wheel-Drive Chassis-Cabs	C2500	131.5	8600	4477	155.5	8600	4202
	C3500	131.5 ²	8600/10,000	4080/5456	155.5 ²	8600/10,000	3824/5200
	C3500	135.5	10,000/11,000	5244/6257	—	—	—
	C3500	159.5	10,000/11,000	5166/6178	—	—	—
	C3500 HD	135.5	15,000	9348	—	—	—
	C3500 HD	159.5	15,000	9358	—	—	—
Four-Wheel-Drive Pickups	K1500	117.5 ³	5600/6100	1469/1945	141.5	6200/6600	1742/2066
	K1500	131.5	5600/6100	1331/1807	155.5	6200/6600	1595/1919
	K2500	—	—	—	141.5	7200	2657
	K2500	131.5	7200/8600	2834/3843	155.5	7200/8600	1448/3567
	K3500	131.5	10,000	4883	155.5	10,000	4604
	Four-Wheel-Drive Chassis-Cabs	K2500	131.5	8600	4210	155.5	8600
K3500		131.5	8600/10,000	3723/5300	155.5	8600/10,000	3444/5021
K3500		131.5	10,000/12,000	4983/6915	—	—	—
K3500		159.5	10,000/12,000	4903/6835	—	—	—

¹ Payload with standard gasoline engine and Fleetside pickup box includes passengers, equipment and cargo. (Payloads with diesel engine models will be less.) ² Dual rear wheels available. ³ Gasoline engine models only.

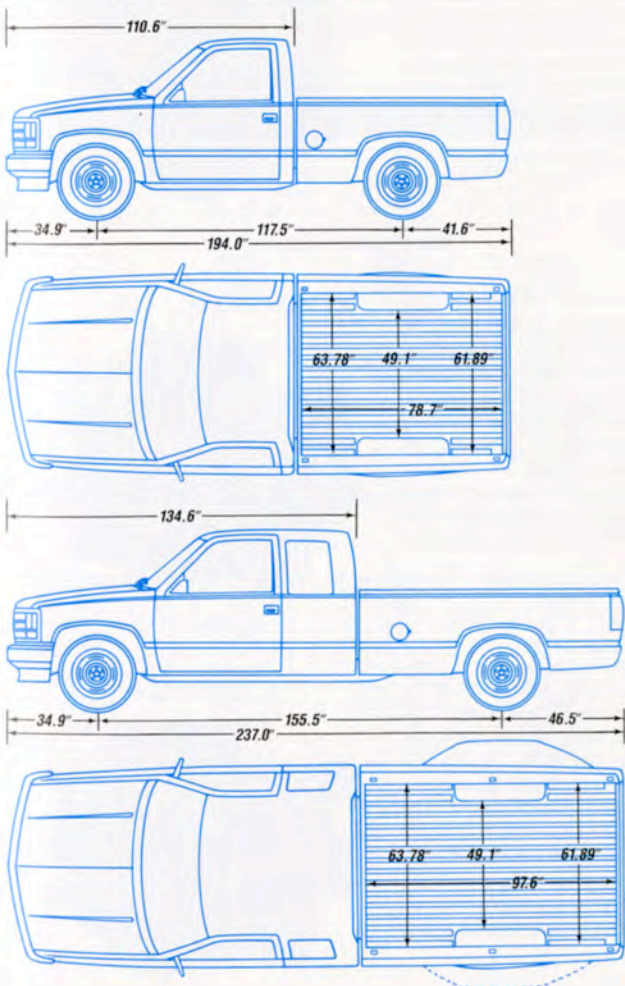

MISC. DIMENSIONS (in.)

	Fleetside		Sportside
	Short Box	Long Box	Short Box
Width at tailgate opening	60.2	60.2	49.1
Width at top of box, rear	61.9	61.9	49.1
Width at top of box, front	63.8	63.8	49.1
Depth of box	19.3	19.3	19.3
Overall box length	82.5	101.4	82.3
Overall box width	76.8	76.8	77.1

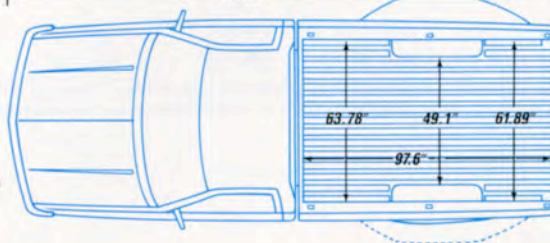
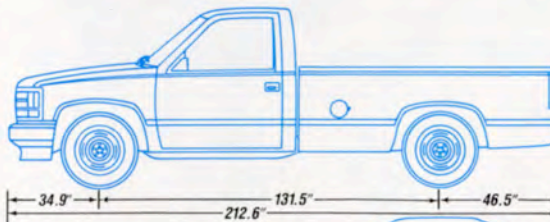
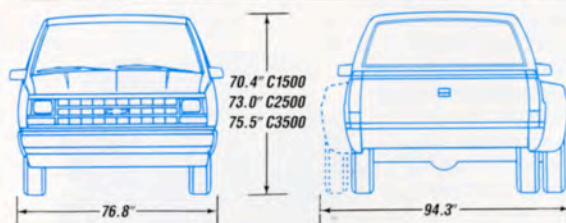

REGULAR-CAB SPECS	C1500	C2500	C2500/C6P ¹	C3500	K1500	K2500	K2500/C6P ¹	K3500
GVWRs (lbs.)	5600/6100	7200	8600	10,000	5600/6100	7200	8600	10,000
Engine- Gas - Diesel	4.3L V6 6.2L V8	4.3L V6 6.2L V8	H.D. 4.3L V6 6.2L V8	7.4L V8 6.2L V8	4.3L V6 6.2L V8	4.3L V6 6.2L V8	H.D. 4.3L V6 6.2L V8	7.4L V8 6.2L V8
Front Suspension- Type - Capacity (lbs.)- 117.5" WB, Gas/Diesel - 131.5" WB, Gas/Diesel - Spring/Torsion Bar (lbs.)- Gas/Diesel ²	2950/— 2950/3150 1475/1475	Independent—Coil Springs — 3150/3400 3800/3800 1800/1800			— 3800/3800 1800/1800	Independent—Torsion Bars — 3450/3925 3925/3925 1875/1875 1875/1875		
Rear Suspension- Type - Capacity (lbs.) - Spring Capacity (lbs. ea.)	3750 1875	4800 2400	6000 3000	Hypoid Drive—Leaf Springs 6000 3750 3000 1875 4800 2400 6000 3000				
Brakes- Type - Front Rotor Size - Rear Drum Size - Booster- Gas - Diesel	11.57" 10"x2.25" Single Hy-Power	11.57" 11.15"x2.75" Dual Hy-Power	12.5" 13"x2.5" Dual Hy-Power	12.5" 13"x2.5" Dual Hy-Power	Hydraulic—Self-Adjusting—Front Disc/Rear Drum 11.57" 11.57" 11.15"x2.75" 12.5" 13"x2.5" Dual Hy-Power			
Anti-Lock Brake System	Rear-Wheel ³							
Electrical - Battery (CCA) Gas/Diesel - Generator (amps)	1-630/2-570 85	1-630/2-570 85	1-630/2-570 85	1-630/2-570 85	1-630/2-570 85	1-630/2-570 85	1-630/2-570 85	1-630/2-570 85
Fuel Tank Capacity (gal.) ⁴	34	34	34	34	34	34	34	34
Steering- Type	Power	Power	Power	Power	Power	Power	Power	Power
Manual Transmission- Gas - Diesel	5-Spd. OD 4-Spd.	5-Spd. OD 4-Spd.	4-Spd. 4-Spd.	4-Spd. 4-Spd.	5-Spd. OD 4-Spd.	5-Spd. OD 4-Spd.	4-Spd. 4-Spd.	4-Spd. 4-Spd.
Transfer Case	—	—	—	—	NP241	NP241	BW1370	BW1370
Tires ⁵	P225/ 75R-15 ⁶	LT225- 75R-16D	LT245/ 75R-16E	LT245/ 75R-16E	LT245/ 75R-16C	LT245/ 75R-16D	LT245/ 75R-16E	LT245/ 75R-16E

¹ C6P is a heavy-duty chassis. ² Computer-selected springs/torsion bars. ³ Operational in 2WD mode only. ⁴ 35 gal. for diesel-powered models, and 25 gal. for all short-wheelbase models. ⁵ Includes optional LT265/75R-16 tires. Tire chains should not be used on Full-Size Pickups equipped with LT265/75R-16 tires (or dual wheels) because they could cause damage to this vehicle. ⁶ Gasoline models only. Diesel models have P235/75R-15 tires. NOTE: The C3500 HD with 15,000-lb. GVWR is not shown here. See your Chevy truck dealer for detailed specifications.

EXTENDED-CAB SPECS	C1500	C2500	C2500/C6P ¹	C3500	K1500	K2500	K2500/C6P ¹	K3500
GVWRs (lbs.)	6200	7200	8600	10,000	6200/6600	7200	8600	10,000
Engine- Gas - Diesel	4.3L V6 6.2L V8	4.3L V6 6.2L V8	H.D. 4.3L V6 6.2L V8	7.4L V8 6.2L V8	4.3L V6 6.2L V8	4.3L V6 6.2L V8	H.D. 4.3L V6 6.2L V8	7.4L V8 6.2L V8
Front Suspension- Type - Capacity (lbs.) - Spring/Torsion Bar Capacity (lbs. ea.) ²	3500 1750-1800	Independent—Coil Springs 3600 3800 1800			3800 1800	Independent—Torsion Bars 3925 1800 3925 1875 4250 1875		
Rear Suspension- Type - Capacity (lbs.) - Spring Capacity (lbs. ea.)	3750 1875	4800 2400	6000 3000	Hypoid Drive—Leaf Springs 6000 3750 3000 1875 4800 2400 6000 3000				
Brakes- Type - Front Rotor Size - Rear Drum Size - Booster- Gas - Diesel	11.57" 10" x 2.25" Dual Hy-Power	11.57" 11.15"x2.75" Dual Hy-Power	12.5" 13"x2.5" Dual Hy-Power	12.5" 13"x2.5" Dual Hy-Power	Hydraulic—Self-Adjusting—Front Disc/Rear Drum 11.57" 11.57" 11.15"x2.75" 12.5" 13"x2.25" Dual Hy-Power			
Anti-Lock Brake System	Rear-Wheel ³							
Electrical - Battery- CCA- Gas/Diesel - Generator (amps)	1-630/2-570 85	1-630/2-570 85	1-630/2-570 85	1-630/2-570 85	1-630/2-570 85	1-630/2-570 85	1-630/2-570 85	1-630/2-570 85
Fuel Tank Capacity (gal.) ⁴	34	34	34	34	34	34	34	34
Steering- Type	Power	Power	Power	Power	Power	Power	Power	Power
Manual Transmission- Gas - Diesel	5-Spd. OD 4-Spd.	5-Spd. OD 4-Spd.	4-Spd. 4-Spd.	4-Spd. 4-Spd.	5-Spd. OD 4-Spd.	5-Spd. OD 4-Spd.	4-Spd. 4-Spd.	4-Spd. 4-Spd.
Transfer Case	—	—	—	—	NP241	NP241	NP241	NP241 ⁵
Tires ⁶	P235/ 75R-15	LT225- 75R-16D	LT245/ 75R-16E	LT245/ 75R-16E	LT245/ 75R-16C	LT245/ 75R-16C	LT245/ 75R-16E	LT245/ 75R-16E

¹ C6P is a heavy-duty chassis. ² Computer-selected springs/torsion bars. ³ Operational in 2WD mode only. ⁴ 35 gal. for diesel-powered models, and 25 gal. for all short-wheelbase models. ⁵ BW1370 @ 10,000 lbs. ⁶ Includes optional LT265/75R-16 tires. Tire chains should not be used on Full-Size Pickups equipped with LT265/75R-16 tires (or dual wheels) because they could cause damage to this vehicle. Consult your Chevy truck dealer for models, engine transmission and tire availability.

C/K FULL-SIZE PICKUP SPECS / ENGINES

ENGINE SPECS

	All Series 1500 and 2500							
Displacement - —Liters (cu.in.)	4.3L (262) V6 w/EFI	H.D. 4.3L (262) V6 w/EFI	5.0L (305) V8 w/EFI	5.7L (350) V8 w/EFI	7.4L (454) V8 w/EFI ¹		6.2L (379) V8 Diesel ²	
Engine Ordering Code	LB4	LB4 ³	L05 ⁴	L05 ⁴	L19 ⁵	LH6 ⁶	LH6 ⁷	LL4
Bore & Stroke (in.)	4.0 x 3.48	4.0 x 3.48	3.74 x 3.48	4.0 x 3.48	4.3 x 4.0	3.98 x 3.82	3.98 x 3.82	3.98 x 3.82
Compression Ratio	9.3 to 1	8.6 to 1	9.3 to 1	9.3 to 1	7.9 to 1	21.3 to 1	21.3 to 1	21.3 to 1
SAE Net Horsepower @ RPM	160 @ 4000	155 @ 4000	175 @ 4000	210 @ 4000	230 @ 3600	140 @ 3600	140 @ 3600	150 @ 3500
SAE Net Torque (lb.-ft.) @ RPM	235 @ 2400	230 @ 2400	270 @ 2400	300 @ 2800	385 @ 1600	255 @ 1900	255 @ 1900	280 @ 2000
	All Series 3500							
Engine Ordering Code		LB4	L05 ^{4,8}	L19 ⁹				LL4
Bore & Stroke (in.)		4.0 x 3.48	4.0 x 3.48	4.3 x 4.0				3.98 x 3.82
Compression Ratio		8.6 to 1	8.6 to 1	7.9 to 1				21.3 to 1
SAE Net Horsepower @ RPM		155 @ 4000	190 @ 4000	230 @ 3600				150 @ 3600
SAE Net Torque (lb.-ft.) @ RPM		230 @ 2400	300 @ 2400	385 @ 1600				265 @ 2000

¹ For 454 SS only. SAE Net Horsepower is 255 @ 4000 and SAE Net Torque is 405 @ 2400. ² Diesel not available in 1500 Series in California. ³ Standard on C/K 2500 with C6P heavy-duty chassis equipment. ⁴ Produced in U.S. or Canada. ⁵ Standard only in the C1500 454 SS. ⁶ With manual transmission. ⁷ With automatic transmission. ⁸ Standard with 3500 models with dual rear wheels. ⁹ Standard with 3500 models with single rear wheels.

4.3 VORTEC GASOLINE

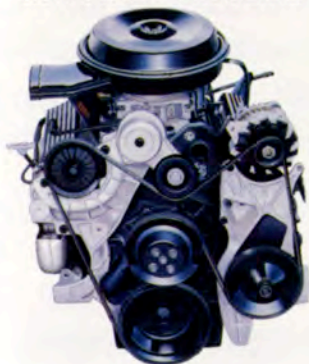

◀ Standard in all 1500 and 2500 Series Chevy Pickups, the 4.3 Liter (262 Cu. In.) Vortec V6 is one of the biggest standard engines available in a half-ton 2WD pickup. Its advanced technology includes swirl-port cylinder heads; Electronic Fuel Injection; electronic spark control to help eliminate spark knock; and even-firing, centralized spark plugs. A heavy-duty emissions version of the 4.3 V6 is standard in C/K2500 models rated at 8600 lbs. GVWR.

5.0 GASOLINE



◀ Optional in 1500 and 2500 Series Chevy Pickups, the 5.0 Liter (305 Cu. In.) V8 is a natural choice for those who want the extra horsepower of a V8. Technological features include swirl-port fuel induction, Electronic Fuel Injection and electronic spark control. Improvements for 1991 include new heavy-duty intake valves and powdered-metal cam sprockets.

5.7 GASOLINE

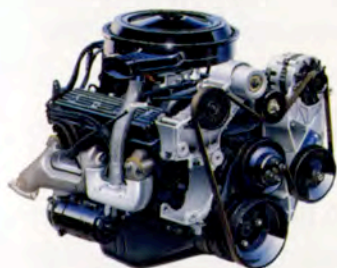

◀ Standard in 3500 Series Chassis-Cabs with dual rear wheels and optional in 1500, 2500 and 3500 Series Chevy Pickups with single rear wheels, the 5.7 Liter (350 Cu. In.) V8 provides dependable power for higher performance requirements. The 5.7 Liter V8 has Electronic Fuel Injection, electronic spark control and, for '91, new heavy-duty intake valves and powdered-metal cam sprockets.

7.4 GASOLINE



◀ Improved for 1991, the 7.4 Liter (454 Cu. In.) V8 is standard in the 454 SS and in 3500 Series and selected 2500 Series with single rear wheels. With power and torque that few engines can match, the 7.4 V8 is ideal for applications that require maximum loads and heavy towing. 1991 refinements over its predecessor include new intake valves and new transmission cooler line brackets for improved reliability.

6.2 DIESEL

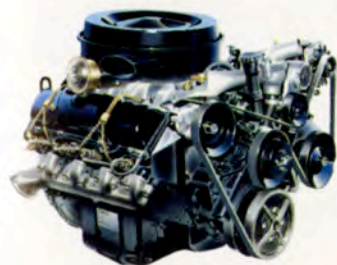

◀ The 6.2 Liter (379 Cu. In.) Diesel V8 is standard in diesel pickup models. This engine is not available in the 454 SS, W/T1500, 1500 Series in California, or in 1500 Series with a 117.5" wheelbase. The 6.2 Diesel features a durable steel camshaft, nodular iron crankshaft, cast-aluminum pistons, a glow-plug starting system for fast cold-engine starts, and excellent emission-control characteristics.

The charts which begin on page 49 clearly indicate the required and recommended options for towing light, medium or heavy trailers with your C/K Full-Size Pickup. The charts also provide Regular Production Option numbers (RPOs) to make ordering easy for you.

STANDARD EQUIPMENT

- A Delco Freedom heavy-duty battery with 630 cold-cranking amps (dual batteries with 570 cold-cranking amps in diesel-powered models).
- An 85-amp Delcotron generator.
- A 1"-diameter front stabilizer bar.
- Power front disc and power rear drum brakes, integrated into a rear-wheel anti-lock brake system (operates in 2WD mode only).
- Power steering.
- Extra-capacity fuel tank: 34-gal. (35-gal. on diesel-powered models, and 25-gal. on all short-wheelbase models).
- Standard steel-belted radial tires that are up to the trailering job. Optional larger tires are not necessary, unless required for fifth-wheel trailering.

TRAILERING SPECIAL PACKAGE

As the charts show, a *Heavy-Duty Trailering Special Package (RPO Z82)* is recommended for towing medium trailers and required for towing heavy trailers. The package includes:

- A weight-distributing platform hitch receiver.
- A 7-wire wiring harness. (See page 62 for further description and a color code to help you with installation.)
- A transmission oil cooler (RPO V02).
- Heavy-duty front and rear shock absorbers (1500 Series only).
- An engine oil cooler (RPO KC4) for gasoline-powered models.

For towing a light trailer (up to 2000 lbs. gross weight), the C/K Pickup's optional rear step bumper is an appropriate deadweight hitch and requires a 1-7/8"-diameter hitch ball, available as an accessory from your Chevy dealer.

For towing a medium trailer (up to 4000 lbs. gross

weight and with a tongue weight of 400 lbs. or under) a 2"-diameter hitch ball (also available from your Chevy dealer) is required for the C/K's rear step bumper.

For towing a heavy trailer (up to 10,000 lbs. gross weight), a weight-distributing platform hitch receiver is required. It's included in RPO Z82—Heavy-Duty Trailering Special Package—or you can buy just the hitch from an outside supplier.

WIRING HARNESES

You will have to splice a wiring harness into your C/K Pickup's electrical system to activate your trailer lights and other electrical systems. A 5-wire wiring harness is sufficient for light trailers and can be purchased from an outside supplier. For medium and heavy trailers, a 7-wire wiring harness is required. It's included in RPO Z82 (Heavy-Duty Trailering Special Package) or can be purchased separately from an outside supplier. The heavy-duty 7-wire wiring harness necessary for fifth-wheel trailering can also be purchased from an outside supplier.

ADDITIONAL INFORMATION

When using the trailering charts, note that, although C/K Pickups can be purchased with manual transmissions, Chevrolet strongly recommends using the 4-speed automatic transmissions for towing.

Additional trailering information is provided on pages 62-63. It includes a chart on dealer-installed trailer hitches, plus a GCWR (Gross Combination Weight Ratings) chart for determining powertrains and rear axle ratios with automatic and manual transmissions.

The C/K trailering information provided in the following charts is for recreational applications. For commercial C/K trailering information, see pages 14-15 of the 1991 *Commercial Vehicles & Motor Home Chassis* brochure.

C/K FULL-SIZE PICKUP TRAILERING

Gasoline-Powered 2WD

(Recommended Equipment in Black, Required Equipment in Red)

TRAILERING EQUIPMENT

Trailer Classification	Light			Medium			Heavy				
Maximum Gross Trailer Weight (lbs.) ¹	2000			4000			7500	9000	10,000	10,000	
Maximum Tongue Load (lbs.)	200			400			850	1000	1000	1000	
Gross Trailer Weight (lbs.) up to ¹	2000			4000			5000	6000	8000	8000	
Maximum Tongue Load (lbs.)	200			400			600	750	1000	1000	
Series	C1500	C2500	C3500	C1500	C2500	C3500	C1500	C2500	C2500/C6P	C3500	
HITCHES & WIRING²											
Trailer Special Package	NR	NR	NR	Z82	Z82	Z82	Z82	Z82	Z82	Z82	
ENGINES											
Minimum Engine	4.3L (262) V6 EFI	LB4	LB4	—	LB4	LB4	LB4	—	—	—	—
	5.0L (305) V8 EFI	—	—	—	—	—	—	L03	L03	—	—
	5.7L (350) V8 EFI	—	—	L05	—	—	L05	L05	L05	L05	L05 ³
	7.4L (454) V8 EFI	—	—	L05	—	—	L05	L19	—	—	L19
AXLES											
Minimum Axle Ratio (to 1) (Gross Trailer Weight [lbs.])	w/Minimum Engine	3.08	3.42	—	3.08	3.42	—	3.42 (6000)	3.73 (7000)	—	—
		—	—	—	—	—	—	—	4.10 (8000)	—	—
	w/5.7L V8 Engine	—	—	4.10	—	—	4.10	3.42 (6500)	3.73 (7500)	4.10 (8500)	4.10 (8500)
		—	—	—	—	—	—	3.73 (7500)	4.10 (9000)	4.56 (10,000)	4.56 (10,000)
	w/7.4L V8 Engine	—	—	3.42	—	—	3.42	4.10 (6000) ⁴	—	—	3.73 (9500)
		—	—	—	—	—	—	—	—	—	4.10 (10,000)
OTHER OPTIONS											
Bumper, Rear Step Type ⁵	V43/ VB3	V43/ VB3	V43/ VB3	V43/ VB3	V43/ VB3	V43/ VB3	V43/ VB3	V43/ VB3	V43/ VB3	V43/ VB3	V43/ VB3
Cooling, Heavy-Duty	V01	V01	V01	NR	NR	NR	NR	NR	NR	NR	NR
Mirrors, Camper Type	NR	NR	NR	DF2	DF2	DF2	DF2	DF2	DF2	DF2	DF2
Driver Convenience Group ⁶	NR	NR	NR	ZQ3	ZQ3	ZQ3	ZQ3	ZQ3	ZQ3	ZQ3	ZQ3

Diesel-Powered 2WD

TRAILERING EQUIPMENT

Trailer Classification	Light			Medium			Heavy				
Maximum Gross Trailer Weight (lbs.) ¹	2000			4000			7500	9000	10,000	10,000	
Maximum Tongue Load (lbs.)	200			400			850	1000	1000	1000	
Gross Trailer Weight (lbs.) up to ¹	2000			4000			5000	6000	8000	8000	
Maximum Tongue Load (lbs.)	200			400			600	750	1000	1000	
Series	C1500	C2500	C3500	C1500	C2500	C3500	C1500	C2500	C2500/C6P	C3500	
HITCHES & WIRING²											
Trailer Special Package	NR	NR	NR	Z82	Z82	Z82	Z82	Z82	Z82	Z82	
ENGINES											
6.2L (379) V8 Diesel	LH6	LH6	LL4	LH6	LH6	LL4	LH6	LH6	LL4	LL4	
AXLES											
Minimum Axle Ratio (to 1) (Gross Trailer Weight [lbs.])		3.08	3.42	4.10	3.42	3.42	4.10	3.42	3.42 (5000)	3.73 (5500)	4.10 (6500)
		—	—	—	—	—	—	—	3.73 (6000)	4.10 (6500)	4.56 (8000)
		—	—	—	—	—	—	—	—	4.56 (8000)	—
OTHER OPTIONS											
Bumper, Rear Step Type ⁵	V43/ VB3	V43/ VB3	V43/ VB3	V43/ VB3	V43/ VB3	V43/ VB3	V43/ VB3	V43/ VB3	V43/ VB3	V43/ VB3	V43/ VB3
Mirrors, Camper Type	NR	NR	NR	DF2	DF2	DF2	DF2	DF2	DF2	DF2	DF2
Driver Convenience Group ⁶	NR	NR	NR	ZQ3	ZQ3	ZQ3	ZQ3	ZQ3	ZQ3	ZQ3	ZQ3

¹ Maximum gross trailer weight includes all passengers and cargo in the pickup, plus any cargo in the trailer. If you order more than the minimum required equipment or carry more than two passengers, the additional weight must be subtracted from the maximum gross trailer weight. ² See "Trailer Special Package" on page 48. ³ With dual rears (RPO R05) only. ⁴ Special limitation on the 454 SS. ⁵ For trailers up to 4000 lbs. and tongue loads up to 400 lbs. A weight-distributing hitch platform is required for tongue loads over 400 lbs. ⁶ Consists of Comfortilt steering wheel and electronic speed control. NR=Not required. NOTE: Model and driveline combinations must be verified by your local dealer for correct emissions equipment.

Gasoline-Powered 4x4

(Recommended Equipment in Black, Required Equipment in Red)

TRAILERING EQUIPMENT

Trailer Classification	Light			Medium			Heavy			
Maximum Gross Trailer Weight (lbs.) ¹	2000			4000			7500	8500	9500	10,000
Maximum Tongue Load (lbs.)	200			400			900	1000	1000	1000
Series	K1500	K2500	K3500	K1500	K2500	K3500	K1500	K2500	K2500/C6P	K3500
HITCHES & WIRING ²										
Trailer Special Package	NR	NR	NR	Z82	Z82	Z82	Z82	Z82	Z82	Z82
ENGINES										
Minimum Engine	4.3L (262) V6 EFI	LB4	LB4	—	LB4	LB4	—	—	—	—
	5.0L (305) V8 EFI	—	—	—	—	—	L03	L03	—	—
	5.7L (350) V8 EFI	—	—	L05	—	—	L05	L05	L05	L05 ³
	7.4L (454) V8 EFI	—	—	L19	—	—	L19	—	—	L19
AXLES										
Minimum Axle Ratio (to 1) (Gross Trailer Weight [lbs.])	w/Minimum Engine	3.42	3.42	—	3.42	3.42	—	3.42 (6000)	3.42 (5500)	—
		—	—	—	—	—	—	3.73 (7000)	3.73 (6500)	—
		—	—	—	—	—	—	—	4.10 (7500)	—
	w/5.7L V8 Engine	—	—	4.10	—	—	4.10	3.42 (6500)	3.73 (7000)	4.10 (8000)
		—	—	—	—	—	—	3.73 (7500)	4.10 (8500)	4.56 (9500)
	w/7.4L V8 Engine	—	—	3.42	—	—	3.42	—	—	—
		—	—	—	—	—	—	—	—	3.73 (9500)
		—	—	—	—	—	—	—	—	4.10 (10,000)
OTHER OPTIONS										
Bumper, Rear Step Type ⁴	V43/ VB3	V43/ VB3	V43/ VB3	V43/ VB3	V43/ VB3	V43/ VB3	V43/ VB3	V43/ VB3	V43/ VB3	V43/ VB3
Cooling, Heavy-Duty	V01	V01	V01	NR	NR	NR	NR	NR	NR	NR
Mirrors, Camper Type	NR	NR	NR	DF2	DF2	DF2	DF2	DF2	DF2	DF2
Driver Convenience Group ⁵	NR	NR	NR	ZQ3	ZQ3	ZQ3	ZQ3	ZQ3	ZQ3	ZQ3

Diesel-Powered 4x4

TRAILERING EQUIPMENT

Trailer Classification	* Light			Medium			Heavy			
Maximum Gross Trailer Weight (lbs.) ¹	2000			4000			6000	6500	8000	7500
Maximum Tongue Load (lbs.)	200			400			750	750	950	900
Series	K1500	K2500	K3500	K1500	K2500	K3500	K1500	K2500	K2500/C6P	K3500
HITCHES & WIRING ²										
Trailer Special Package	NR	NR	NR	NR	NR	NR	Z82	Z82	Z82	Z82
ENGINE										
6.2L (379) V8 Diesel	LH6	LH6	LL4	LH6	LH6	LL4	LH6	LH6	LL4	LL4
AXLES										
Minimum Axle Ratio (to 1) (Gross Trailer Weight [lbs.])	3.42	3.42	4.10	3.42	3.42	4.10	3.42 (5000)	3.42 (4500)	3.73 (5500)	3.73 (5500)
	—	—	—	—	—	—	—	3.73 (6000)	3.73 (5500)	4.10 (6500)
	—	—	—	—	—	—	—	—	4.10 (6500)	4.56 (7500)
	—	—	—	—	—	—	—	—	—	4.56 (7500)
OTHER OPTIONS										
Bumper, Rear Step Type ⁴	V43/VB3	V43/VB3	V43/VB3	V43/VB3	V43/VB3	V43/VB3	V43/VB3	V43/VB3	V43/VB3	V43/VB3
Mirrors, Camper Type	NR	NR	NR	DF2	DF2	DF2	DF2	DF2	DF2	DF2
Driver Convenience Group ⁵	NR	NR	NR	ZQ3	ZQ3	ZQ3	ZQ3	ZQ3	ZQ3	ZQ3

¹ Maximum gross trailer weight includes all passengers and cargo in the pickup, plus any cargo in the trailer. If you order more than the minimum required equipment or carry more than two passengers, the additional weight must be subtracted from the maximum gross trailer weight. ² See "Trailer Special Package" on page 48. ³ With dual rears (RPO R05) only. ⁴ For trailers up to 4000 lbs. and tongue loads up to 400 lbs. A weight-distributing hitch platform is required for tongue loads over 400 lbs. ⁵ Consists of ComfortLift steering wheel and electronic speed control. NR = Not Required. NOTE: Model and driveline combinations must be verified by your local dealer for correct emissions equipment.

C/K FULL-SIZE PICKUP TRAILERING

Gasoline-Powered Fifth Wheel with Kingpin-Type Hitch

(Recommended Equipment in Black, Required Equipment in Red)

TRAILERING EQUIPMENT

Trailer Classification	Heavy		Heavy		Heavy		Heavy	
Maximum Gross Trailer Weight (lbs.) ¹	8000	9000	10,000	14,000	7500	8500	9500	13,500
Series	C2500		C2500/C6P	C3500	K2500		K2500/C6P	K3500
Maximum GVWR (lbs.)	7200	7200	8600	8600	7200	7200	8600	8600
Maximum Payload (lbs.)	2582	2533	3476	3335	2266	2245	3120	2979
ENGINES								
Minimum Engine	5.0L (305) V8 EFI	L03	—	—	L03	—	—	—
	5.7L (350) V8 EFI	—	L05	L05	—	L05	L05	—
	7.4L (454) V8 EFI	—	—	L19	—	—	—	L19
AXLES								
Minimum Axle Ratio (to 1) (Gross Trailer Weight [lbs.])	3.73 (7000)	3.42 (6500)	3.73 (7000)	3.42 (8500)	3.42 (5500)	3.42 (6000)	3.73 (6500)	3.42 (8000)
	4.10 (8000)	3.73 (7500)	4.10 (8500)	3.73 (9500)	3.73 (6500)	3.73 (7000)	4.10 (8000)	3.73 (9000)
	4.10 (7000)	4.10 (9000)	4.56 (10,000)	4.10 (11,000)	4.10 (7500)	4.10 (8500)	4.56 (9500)	4.10 (10,500)
	—	—	—	4.56 ¹ (14,000)	—	—	—	4.56 ² (13,500)
OTHER OPTIONS								
Mirrors, Camper Type	DF2	DF2	DF2	DF2	DF2	DF2	DF2	DF2
Driver Convenience Group ³	ZQ3	ZQ3	ZQ3	ZQ3	ZQ3	ZQ3	ZQ3	ZQ3

Diesel-Powered Fifth Wheel with Kingpin-Type Hitch

TRAILERING EQUIPMENT

Trailer Classification	Heavy	Heavy	Heavy	Heavy	Heavy	Heavy
Maximum Gross Trailer Weight (lbs.) ¹	7000	8000	8000	6500	7500	7500
Series	C2500	C2500/C6P	C3500	K2500	K2500/C6P	K3500
Maximum GVWR (lbs.)	7200	8600	10,000	7200	8600	10,000
Maximum Payload (lbs.)	2625	4100	5200	1725	3800	5900
ENGINE						
6.2L (379) V8 Diesel	LH6	LL4	LL4	LH6	LL4	LL4
AXLES						
Minimum Axle Ratio (to 1) (Gross Trailer Weight [lbs.])	3.42 (5000)	3.73 (5500)	4.10 (6500)	3.42 (4500)	3.73 (5000)	4.10 (6000)
	3.73 (6000)	4.10 (6500)	4.56 (8000)	3.73 (5500)	4.10 (6000)	4.56 (7500)
	4.10 (7000)	4.56 (8000)	—	4.10 (6500)	4.56 (7500)	—
OTHER OPTIONS						
Mirrors, Camper Type	DF2	DF2	DF2	DF2	DF2	DF2
Driver Convenience Group ³	ZQ3	ZQ3	ZQ3	ZQ3	ZQ3	ZQ3

¹ Maximum gross trailer weight includes all passengers and cargo in the pickup, plus any cargo in the trailer. If you order more than the minimum required equipment or carry more than two passengers, the additional weight must be subtracted from the maximum gross trailer weight. ² Requires dual rears. ³ Consists of ComfortLift steering wheel and electronic speed control. NOTE: Model and driveline combinations must be verified by your local dealer for correct emissions equipment.

FIFTH-WHEELING

There are two types of pickup fifth-wheel hitch installations. The first has the fifth wheel on a bar mounted on brackets attached to the frame and the bed of the pickup and supported by braces on the fender housings. NOTE: Diagonal bracing between the brackets is required. The kingpin is mounted on the trailer.

With the second type, the kingpin is mounted in the bed of the pickup box, and the fifth wheel is mounted on the trailer. This type of hitch is supplied and installed by the trailer manufacturer.

Fifth-wheel trailers have a greater percentage of their weight on the kingpin (tongue load) than a conventional trailer. Because of this fact, greater attention must be given to the maximum allowable payload and GVWR. The charts above show the maximum allowable payload and GVWR for each application, which should not be exceeded. The weight of any additional equipment and all passengers must be subtracted from the payload weight shown to determine the maximum kingpin load available.



▲ V3500 (4x4) Big Dooley Crew Cab in Frost White.

More in-cab space in a tough 4-door truck.



R/V Crew Cab Fleetside.



R/V Bonus Cab Fleetside.



R/V Chassis-Cab.

CONTENTS

Crew Cab	54
Bonus Cab	54
Chassis-Cab	54
Standards / Colors	56
Options / Specs	58
Trailerage	60



▲ R3500 (2WD) Big Dooley Crew Cab in Frost White with utility body provided by outside supplier.

▶ Crew Cab Saddle interior with standard Cheyenne trim.



◀ R3500 (2WD) Big Dooley Crew Cab with Special Two-Tone in Mariner Blue and Steel Gray Metallic.

Four doors and plenty of room for six people.

Chevy Crew Cab and Bonus Cab models belong to a series all their own—R/V (R for 2WD, V for 4x4). The 1991 4-door R/V models offer distinct advantages over conventional cabs. The Crew Cab offers a full-width, forward-facing rear bench seat that matches the front bench seat and allows six adult passengers to ride in comfort. The R/V Bonus Cab model comes without the rear bench seat and offers 55.8 cu. ft. of lockable rear cargo space. All four doors of both models open wide for easy entrance and exit. R/V Crew Cabs and Bonus Cabs are available both as pickups and as chassis-cabs. They are designed for con-

ventional body-mounting systems and power takeoff applications and can be ordered with options that raise GVWRs well beyond 10,000 lbs. for chassis-cabs. Properly equipped, R/V payload capacities can range up to 5662 lbs. Payload includes passengers, cargo, body and equipment.

MODEL SELECTOR



R/V3500 Crew Cab Fleetside.



R/V3500 Bonus Cab Fleetside.



R/V3500 Chassis-Cab.

	Crew Cab R/V3500	Bonus Cab R/V3500	Chassis-Cab R/V3500
MODELS			
Std. Seating Capacity	6	3	6 (Crew Cab) 3 (Bonus Cab)
Drives	2WD(R), 4x4(V)	2WD(R), 4x4(V)	2WD(R), 4x4(V)
Wheelbase (in.)	164.5	164.5	164.5
Box Size	8 ft. (except Chassis-Cab)	8 ft. (except Chassis-Cab)	8 ft. (except Chassis-Cab)
Min./Max. Payload (lbs.) ¹	3761/5161 (R) 3428/5268 (V)	3761/5161 (R) 3428/5268 (V)	4379/5662 (R) 3850/5760 (V)
Min./Max. GCW (lbs.) ²	9000/10,000 (R) 9200/10,000 (V)	9000/10,000 (R) 9200/10,000 (V)	9000/10,500 (R) 9200/11,000 (V)

TRIM LEVELS	Cheyenne	Silverado
Std. Fabric	Custom Vinyl	Custom Vinyl
Opt. Fabric		Custom Cloth
Interior Colors ³	Dark Blue, Garnet Red and Saddle	Dark Blue, Garnet Red and Saddle

¹ Payload includes passengers, equipment and cargo. Payloads indicated are for gasoline engine models only. ² GCW (Gross Combined Weight) includes vehicle, trailer, people, cargo and equipment. GCWs indicated are for gasoline-engine models only. ³ Your choice of exterior will determine your choice of interior color. See your Chevy truck dealer for details.

TRIM FEATURES

INTERIOR	Cheyenne	Silverado
Door Sill Plates: Bright metal	■	■
Floor Covering		
Front embossed black rubber mat (also rear in Extended-Cab)	■	
Color-keyed carpeting (in front compartment only for Bonus Cabs)		■
Headliner		
Vinyl	■	
Full-length, cloth		■
Insulation and Sound-Deadening Material		
On dash panel and under floor mats	■	■
Additional Sound-Deadening Materials		■
Lights: Map light, dome light, instrument cluster and cab interior; shift point indicator light with manual transmission	■	■
Mirror: 10" day/night rearview mirror	■	■
Tools: Mechanical jack and wheel wrench	■	■
Windshield Wipers/Washers: Electric, pulse	■	■
INSTRUMENT PANEL / STEERING COLUMN		
Ashtray Light		■
Cigarette Lighter	■	■
Gages: Speedometer with trip odometer, fuel voltmeter, engine temperature and oil pressure	■	■
Glove Box Light		■
Headlamps-On Warning Buzzer	■	■
Heater and Defogger: Deluxe outside-air type with side window defoggers	■	■
Hood Lock Release: Inside-operated	■	■
Radio: Electronically tuned AM with digital clock and antenna	■	■
Steering Column: Energy-absorbing	■	■
Stowage Box (RH side): Glove box with beverage holder inside door	■	■
Switches: Interior, exterior and instrument panel lights, heater fan; on instrument panel; directional signals, headlamp high/low beam, windshield wipers/washers and hazard warning; on steering column. Key-in ignition warning buzzer	■	■
Warning Lights: Safety belt, service/parking brake, direction/hazard signal and high beams	■	■
DOOR PANELS		
Painted Areas: Same color as primary exterior color, trim color same as seat trim	■	■
Trim Panels		
Color-keyed molded plastic with integral padded armrests	■	
Color-keyed plastic with cloth inserts, door-closing assist straps, plus carpeting and bright trim strips on lower portions of trim panels		■
Vinyl Stowage Pockets: On front doors		■
SEATING		
Bench Seat		
Foam-padded full-width vinyl	■	
Foam-padded cloth/vinyl or all-vinyl		■
Safety Belts: In all seating positions with lap/shoulder belts located at all outboard seating positions	■	■

R/V FULL-SIZE PICKUP STANDARDS / OPTIONS

EXTERIOR	Cheyenne	Silverado
Body-Side and Rear Moldings: Bright-accented		■
Bright Trim: On front side marker lights and taillights		■
Bumper: Front, chromed	■	■
Grille: Argent molded plastic Dark argent and chrome trim	■	■
Mirrors: Right-hand and left-hand Below Eyeline	■	■
Tailgate Removable with outlined embossed "Chevrolet" lettering ¹ Removable with "Chevrolet" lettering over bright aluminum applique ¹	■	■
Tow Hooks (4x4 models only)	■	■
Wheels: White with bright metal ² hubcaps	■	
Wheel Covers: Full ²		■
Wheel Opening Moldings: ² Bright-accented		■
EXTERIOR LIGHTING		
Backup Lamps: Integral with tail lamps	■	■
Directional/Parking Lamps: Front and rear	■	■
Headlamps Two, rectangular halogen Four, rectangular halogen	■	■
Side Marker Lamps: Front	■	■

¹ Not available with Chassis-Cab models. ² Except dual rear wheel models.

INTERIOR COLORS	Blue	Garnet	Saddle
CHEYENNE			
Custom Vinyl Bench Seat	■	■	■
SILVERADO			
Custom Vinyl Bench Seat	■	■	■
Custom Cloth Bench Seat	■	■	■
EXTERIOR COLORS ¹			
Midnight Black	■	■	■
Mariner Blue	■		
Midnight Blue	■		■
Steel Gray Met.	■	■	
Apple Red		■	■
Wheat	■ ²	■	■
Frost White	■	■	■

¹ Ask your Chevy truck dealer for information on Special and Deluxe Two-Tone combinations.

² Not available with Chassis-Cab models.

OPTIONAL TWO-TONE



▲ **Special Two-Tone** includes decal striping above the beltline, plus a hood ornament. The primary color appears above the striping, the secondary color below the striping. Available only with dual rear wheels. Not available on Chassis-Cab models.



▲ **Deluxe Two-Tone** includes decal striping at the beltline, plus a hood ornament, bright body-side moldings, bright wheel-opening moldings and bright rear lower moldings. The primary color appears above the striping and below the moldings. The secondary color appears between the striping and moldings. Not available with dual rear wheels or on Chassis-Cab models.

EXTERIOR COLORS

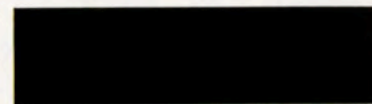

Midnight Black



Apple Red



Mariner Blue

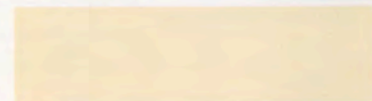

Wheat



Midnight Blue

Frost White



Steel Gray Met.

INDIVIDUALLY AVAILABLE OPTIONS.

(May be added to Cheyenne or Silverado trim if not already included.)

TRIM LEVEL	Cheyenne	Silverado
Air Conditioning	■	■
Bumper Equipment		
Painted rear step (N/A with Chassis-Cab models)	■	■
Chromed rear step (N/A with Chassis-Cab models)	■	■
Guards, front bumper, chromed	■	■
Cargo Area Lamp	■	■
Cold Climate Package (incl. engine block heater and coolant protection—not available with diesel models)	■	■
Commercial Chassis Equipment, Special (R3500 only)	■	■
Driver Convenience Group: Comfortilt steering wheel and electronic speed control	■	■
Dual Rear Wheels	■	■
Glass, Tinted: All windows	■	■
Lamps, Roof Marker (std. on 4x4)	■	■
Mirrors		
Below Eyeline, black-painted	■	■
Below Eyeline, stainless steel	■	■
Camper, stainless steel	■	■
Operating Convenience Group: Power door locks and power windows	■	■
Rear Axle Locking Differential (N/A with dual rear wheels)	■	■
Stabilizer Bar (R3500 only, N/A with commercial/camper chassis equipment)		
Front: 1" diameter	■	■
Front Heavy-Duty: 1.25" diameter	■	■
Spare Wheel & Tire Carrier		
Glide-out	■	■
Slide-mounted (N/A with Chassis-Cab models)	■	■
Springs: Rear main and auxiliary (included with dual rear wheels)	■	■
Windows: Sliding rear	■	■



▲ Standard ETR AM radio with digital clock.



▲ Optional ETR AM/FM stereo radio with premium dual rear speakers, seek and scan and digital clock.



▲ Optional ETR AM/FM stereo radio with premium dual rear speakers, seek and scan, stereo cassette tape player and digital clock.



▲ Optional ETR AM stereo 1/FM stereo radio with premium dual rear speakers, seek and scan, graphic equalizer and digital clock, plus stereo cassette tape player with search and repeat.

¹ Receives C-Quam[®] AM stereo broadcasts. Most AM stations across the country broadcast in C-Quam, but some do not. Check with your local stations for compatibility in your area.

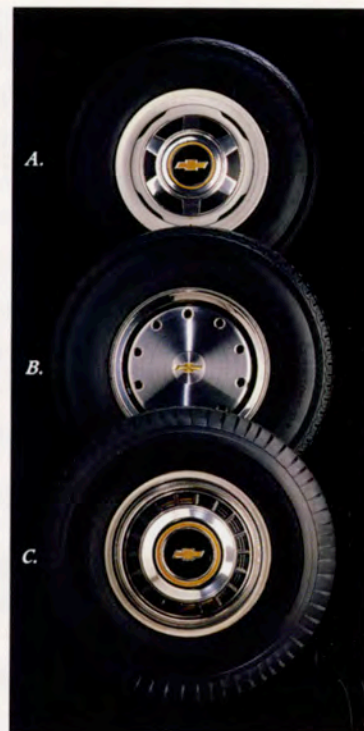

A. Standard wheels with bright hubcaps.

B. Optional 2WD wheel covers (included with Silverado trim).

C. Optional wheel covers (Big Dooley 2WD only).

▼ Optional Driver Convenience Group consists of Comfortilt steering wheel and electronic speed control.



▲ Optional cargo-box light and sliding rear window.

R/V FULL-SIZE PICKUP OPTIONS / SPECIFICATIONS

SPECS	R30943	V30943
GVWR Range (lbs.)	9000-9600-10,000	9200-10,000
Engine- Gas	5.7L V8	5.7L V8
- Diesel	6.2L V8	6.2L V8
Front Suspension- Type	Independent Coil Springs	Hypoid Drive Leaf Springs
- Axle Capacity (lbs.)	4000	4500
- Spring Capacity (lbs. ea.)	2000	2250
Rear Suspension- Type	Hypoid Drive-Leaf Springs	
- Axle Capacity (lbs.)	7500	7500
- Spring Capacity (lbs. ea.)	3500	3500
Brakes- Type	Hydraulic Self Adjusting Front Disc/Rear Drum	
Front Rotor Size	12.5"	12.5"
Rear Drum Size	13"x3.5"	13"x3.5"
Booster- Gas/Diesel	Hy-Power	Hy-Power
Battery- CCA- Gas/Diesel	1-630/2-540	1-630/2-540
Generator (amps)	100	100
Fuel Tank (gal.)	40	40
Steering- Type	Power	Power
Transmission	4-Spd. Manual	4-Spd. Manual
Transfer Case	—	NP205
Tires	LT235/85R-16E	LT235/85R-16E

GROSS VEHICLE WEIGHT RATINGS

GVW Rating (lbs.)	GAWR (lbs.) ¹ Front/Rear	Equipment Required
	R3500	
9000	4000/6084	(N/A Z76, Z81 or R05)
9600	4000/6084	Z81 (N/A R05)
10,000	4000/7500	R05
10,500 ²	4000/7500	R05 & G60 or G52
	V3500	
9200	4500/6084	(N/A R05)
10,000	4500/7500	R05
11,000 ²	4500/7500	R05 & G60 or G52

¹ GAWRs (Gross Axle Weight Ratings) shown are the maximum for each axle with equipment listed. ² Requires Chassis-Cab with dual rear wheels. N/A - Not Available.

MISCELLANEOUS DIMENSIONS (in.)

Width at Tailgate Opening	65.0
Width at Top of Box, Rear	65.0
Width at Top of Box, Front	65.0
Depth of Box	19.7 ¹

¹ At front end (19.3 in. at rear).

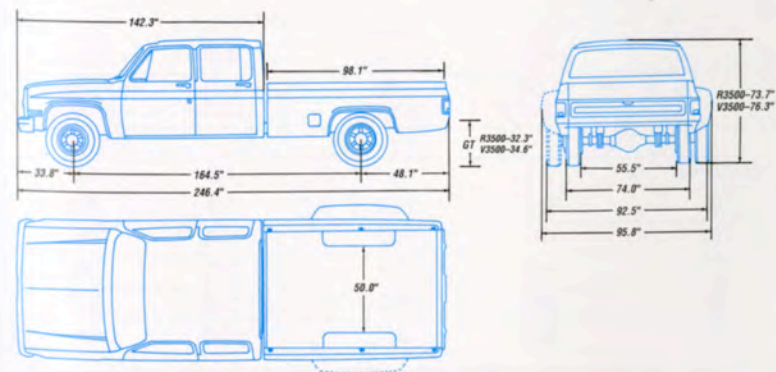

ENGINE SPECS	All Series 3500		
Displacement—Liters (cu. in.)	5.7L (379) V8 w/EFI	7.4L (454) V8 w/EFI	6.2L (379) Diesel V8
Engine Ordering Code	L05	L19	LL4
Bore & Stroke (in.)	4.0 x 3.48	4.3 x 4.0	3.98 x 3.82
Compression Ratio	8.6 to 1	7.9 to 1	21.3 to 1
SAE Net Horsepower @ RPM	190 @ 4000	230 @ 3600	155 @ 3500
SAE Net Torque (lb.-ft.) @ RPM	300 @ 2400	385 @ 1600	285 @ 2000

POWER TEAMS

Engines	Transmissions		Axle Ratios				GVWRs (lbs.)
	4-Spd. Manual	3-Spd. Auto.	3.42	3.73	4.10	4.56	
R3500							
V8 5.7 Liter w/EFI (350 Cu. In.)	Std.	—	Std.	Opt.	Opt.	—	9000
	—	Opt.	—	—	Std.	Opt.	9000
	Std.	Opt.	—	—	Std.	Opt.	9600
V8 7.4 Liter w/EFI (454 Cu. In.)	Std.	Opt. ¹	—	—	Std.	Opt.	10,000/10,500 ²
	Std.	Opt. ¹	—	—	Std.	Opt.	10,000
	Std.	Opt. ¹	—	—	Std.	Opt.	10,500 ²
Diesel 6.2 Liter V8 (379 Cu. In.)	Std.	Opt.	—	—	Std.	Opt.	9000/9600
	Std.	Opt. ¹	—	—	Std.	Opt.	10,000
	Std.	Opt. ¹	—	—	Opt.	Std.	10,500 ²
V3500							
V8 5.7 Liter w/EFI (350 Cu. In.)	Std.	—	Std.	Opt.	Opt.	—	9200
	—	Opt.	—	—	Std.	Opt.	9200
	Std.	Opt. ¹	—	—	Std.	Opt.	10,000/11,000 ²
V8 7.4 Liter w/EFI (454 Cu. In.)	Std.	Opt. ¹	—	—	Opt.	Std.	11,000 ²
	Std.	Opt. ¹	—	—	Std.	Opt.	9200
	Std.	Opt. ¹	—	—	Std.	Opt.	10,000
Diesel 6.2 Liter V8 (379 Cu. In.)	Std.	Opt. ¹	—	—	Opt.	Std.	11,000 ²
	Std.	Opt.	—	—	Std.	Opt.	9200
	Std.	Opt. ¹	—	—	Std.	Opt.	10,000

¹ Requires heavy-duty radiator and transmission oil cooler. ² Requires Chassis-Cab with dual rear wheels.

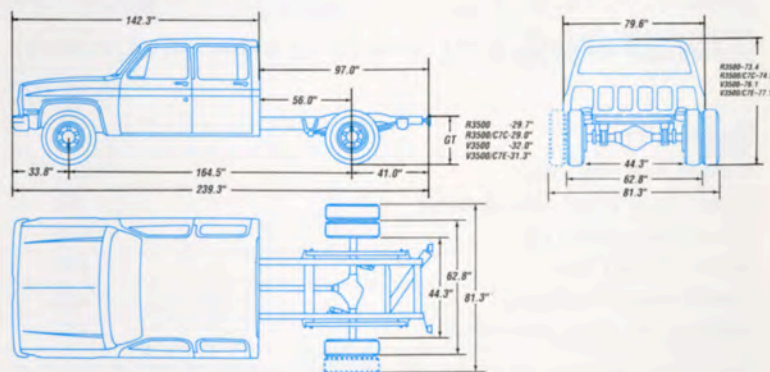

Gasoline-Powered R/V Regular Hitch/Fifth Wheel with Kingpin-type Hitch

(Recommended Equipment in Black, Required Equipment in Red)

TRAILERING EQUIPMENT

Trailer Classification	Medium		Heavy		Heavy		
			Crew Cab ¹		Crew Cab ¹	5th Wheel	
Maximum Gross Trailer Weight (lbs.) ²		4000	10,000	10,000	13,500	13,000	
Maximum Tongue Load (lbs.)		400	1000	1000			
Series	R3500	V3500	R3500	V3500	R3500	V3500	
Maximum GVWR (lbs.)	—	—	—	—	9000	9200	
Maximum Payload (lbs.)	—	—	—	—	3250	3000	
ENGINES							
Minimum Engine	5.7L (350) V8 EFI	L05	L05	L05	L05	L05	
	7.4L (454) V8 EFI	—	—	L19	L19	L19	
AXLES							
Minimum Axle Ratio (to 1) (Gross Trailer Weight [lbs.])	W/5.7L V8 Engine	4.10	4.10	4.10 (7500)	4.10 (7000)	4.10 (7000)	4.10 (6500)
		—	—	4.56 (9000)	4.56 (8500)	4.56 (8500)	4.56 (7500)
		—	—	3.42 (8000)	3.73 (8500)	3.42 (7500)	3.73 (8500)
		—	—	3.73 (9000)	4.10 (9500)	3.73 (9000)	4.10 (10,000)
	W/7.4L V8 Engine	—	—	4.10 (10,000)	4.56 (10,000)	4.10 (10,500)	4.56 (13,000)
		—	—	4.56 (10,000)	—	4.56 (13,500)	—
		OTHER OPTIONS					
		Bumper, Rear Step Type	V42/V43	V42/V43	—	—	NR
Carrier, Spare Wheel, Side-Mounted	NR	NR	P13	P13	NR	NR	
Cooler, Engine Oil	NR	NR	KC4	KC4	KC4	KC4	
Cooler, Transmission Oil	NR	NR	V02	V02	V02	V02	
Cooling, Heavy-Duty	V02	V02	V02	V02	V02	V02	
Mirrors, Camper Type	DF2	DF2	DF2	DF2	DF2	DF2	
Driver Convenience Group ³	ZQ3	ZQ3	ZQ3	ZQ3	ZQ3	ZQ3	
Stabilizer Bar, Front, Heavy-Duty	F58	Std.	F58	Std.	F58	Std.	

Diesel-Powered R/V Regular Hitch/Fifth-Wheel with Kingpin-Type Hitch

TRAILERING EQUIPMENT

Trailer Classification	Medium		Heavy		Heavy	
			Crew Cab ¹		Crew Cab ¹	5th Wheel
Maximum Gross Trailer Weight (lbs.) ²		4000	7500	7000	7500	7000
Maximum Tongue Load (lbs.)		400	900	850		
Series	R3500	V3500	R3500	V3500	R3500	V3500
Maximum GVWR (lbs.)	—	—	—	—	9000	9200
Maximum Payload (lbs.)	—	—	—	—	3150	2875
AXLES						
Minimum Axle Ratio (to 1) (Gross Trailer Weight [lbs.])	4.10	4.10	4.10 (6000)	4.10 (5500)	4.10 (6000)	4.10 (5500)
	—	—	4.56 (7500)	4.56 (7000)	4.56 (7500)	4.56 (7000)
OTHER OPTIONS						
Bumper, Rear Step Type	V42/V43	V42/V43	—	—	NR	NR
Carrier, Spare Wheel, Side-Mounted	NR	NR	P13	P13	NR	NR
Cooler, Transmission Oil	V02	V02	V02	V02	V02	V02
Mirrors, Camper Type	DF2	DF2	DF2	DF2	DF2	DF2
Driver Convenience Group ³	ZQ3	ZQ3	ZQ3	ZQ3	ZQ3	ZQ3
Stabilizer Bar, Front, Heavy-Duty	F58	Std.	F58	Std.	F58	Std.

¹ Bonus Cab model also available. ² Maximum gross trailer weight includes all passengers and cargo in the pickup, plus any cargo in the trailer. If you order more than the minimum required equipment or carry more than two passengers, the additional weight must be subtracted from the maximum gross trailer weight. ³ Consists of Comfortilt steering wheel and electronic speed control. NR - Not required. Std. - Standard. NOTE: Model and driveline combinations must be verified by your local Chevy truck dealer for correct emissions equipment.

R/V FULL-SIZE PICKUP TRAILERING

The charts on page 60 on gasoline-powered R/Vs and diesel-powered R/Vs clearly indicate the required and recommended options for towing medium or heavy trailers with your new R/V Full-Size Pickup. The charts also provide Regular Production Option numbers (RPOs) to make ordering easy for you.

STANDARD EQUIPMENT

- A Delco Freedom heavy-duty battery with 630 cold-cranking amps (dual batteries with 570 cold-cranking amps in diesel-powered models).
- An 85-amp Delcotron generator.
- Power front disc and power rear drum brakes.
- Power steering.
- Auxiliary fuel tank (total capacity: 40 gals.).
- Standard steel-belted radial tires that are up to the trailering job. Optional larger tires are not necessary, unless required for fifth-wheel trailering.

TOWING MEDIUM / HEAVY TRAILERS

For towing a medium trailer (up to 4000 lbs. gross weight and with a tongue weight of 400 lbs. or under), a 2"-diameter hitch ball (available from your Chevy dealer) is required for the R/V's rear step bumper. For towing a heavy trailer (up to 10,000 lbs. gross weight), a weight-distributing platform hitch receiver is required. It's available as a dealer-installed accessory—or you can buy the hitch from an outside supplier.

FIFTH-WHEELING

If you plan to "fifth wheel" with a gross weight of up to 13,500 lbs., please read the "fifth wheel" information on page 51 of the C/K section, which applies equally to R/V models.

ADDITIONAL INFORMATION

A GCWR (Gross Combination Weight Ratings) chart is provided on page 63, in the event you wish to use GCWRs for determining the right powertrain and rear axle ratio for your trailering needs. The GCWR chart works for both C/K and R/V Pickups, and covers both manual and automatic transmissions.

Additional trailering information is provided on page 62. It includes a chart on dealer-installed trailer hitches and a color-coded 7-wire wiring harness illustration.

You will have to splice a wiring harness into your R/V Pickup's electrical system to activate your trailer lights and other electrical systems. For medium and heavy trailers, a 7-wire wiring harness is required for both conventional and "fifth wheel" trailering and can be purchased from an outside supplier.

When using the trailering charts, note that, although R/V Pickups can be purchased with manual transmissions, Chevrolet strongly recommends using the 3-speed automatic transmission for towing.

Other important trailering information is available in the Owner's Manual of every 1991 Chevy truck.

COMMERCIAL TRAILERING INFORMATION

The R/V trailering information provided in the preceding charts is for recreational applications. For commercial R/V trailering information, see pages 14-15 of the 1991 *Commercial Vehicles* brochure.

Chevrolet offers a wide selection of available options for trailering, and only a few of them are illustrated and described here. Check with your Chevrolet dealer for complete information on these items, as well as many others, for your Chevy truck.

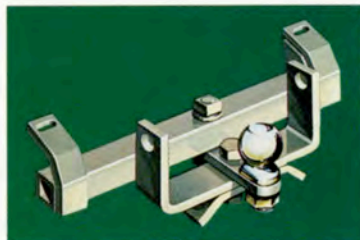

▲ Light-duty trailer hitch for hauling trailers up to 2000 lbs. with a maximum tongue load of 200 lbs. A 1-7/8"-diameter ball is included. (Dealer-installed accessory. See chart for part numbers.)



▲ A weight-distributing platform hitch receiver is required when towing trailers over 2000 lbs. Installs quickly and easily. (Dealer-installed accessory. See chart below for part numbers.)

▼ An optional 5-wire wiring harness is used with trailers up to 2000 lbs. gross weight, and a 7-wire for larger trailers. Harnesses tie into vehicle's electrical system to provide electricity for your trailer's lights, plus electric brakes or battery charging. The color code shown below should be used when installing trailer wiring harnesses.

- BLUE. Use for electric trailer brakes or auxiliary wiring.
- RED. Use for battery charging. Connects to starter solenoid (7-wire harness only).
- LIGHT GREEN. Backup lights (7-wire harness only).
- BROWN. Taillight and running lights.
- YELLOW. Left stop and turn signal.
- DARK GREEN. Right stop and turn signal.
- WHITE. Ground.



▲ A 1-7/8"-diameter hitch ball is standard with light-duty hitches. Also available as an accessory: Part No. 981148. A 2"-diameter ball is also available for hitches as Part No. 980670.



COOLERS AND COOLING

Trailering creates higher-than-normal temperatures in coolant, engine and transmission oil. To help control these temperatures, Chevy offers the following separate options.

RPO VO1: This heavy-duty radiator option provides increased radiator and transmission cooling. (Included with optional automatic transmission or air conditioning.)

RPO VO2: This is an extra-capacity heavy-duty automatic transmission oil cooler option. (Included in RPO Z82 Trailering Special Package.)

RPO KC4: This optional engine oil cooler circulates oil through a special cooler mounted in the radiator. (Included in RPO Z82 Trailering Package.)

MIRRORS

Chevy trucks used as tow vehicles will require outside mirrors with extensions that exceed the width of the trailer to be towed. Optional mirrors with larger mounting brackets are available with all Chevy truck models.

DEALER-INSTALLED HITCHES

Trailer Classification	Light	Light/Medium	Heavy	Heavy
Gross Trailer Weight (lbs.) up to	2000	4000	6000	7000
Maximum Tongue Load (lbs.)	200	400	750	850
Type of Hitch	Deadweight ¹	Rear Step Bumper ²	Weight-Distrib. Platform	Weight-Distrib. Platform
S-10 Fleetside Pickup	—	See Footnotes ^{3,4}	998485 ⁵	—
R/V Fleetside Pickup	996922 ⁶	996738-Painted 996736-Chrome	—	884582 ⁷
C/K Fleetside Pickup (long wheelbase only)	Load	999862-Painted 999863-Chrome	—	999772 ⁷

¹ Deadweight hitch includes 1-7/8" ball. ² 1-7/8" ball for step-type bumper - Part No. 981148. All except S-10. Part No. 998391 for S-10. 2" ball for step-type bumper - Part No. 980670. All except S-10. Part No. 998392 for S-10. ³ Maximum 2000-lb. trailer with 200-lb. tongue load. ⁴ Standard bumper painted black - Part No. 997859; chrome with strip - Part No. 997883, or sport bumper painted black with rub strip - Part No. 998020. ⁵ Maximum trailer weight 5000 lbs. Maximum tongue load 600 lbs. ⁶ Requires a rear bumper. ⁷ Requires a rear bumper. Not available with underframe spare tire carrier.

CAUTION: If your light-duty Chevy truck is equipped with a rear step bumper, the V-shaped foot on your trailer tongue could dent the bumper in a sharp turn. Before towing a trailer with this foot in place, check the distance from the foot front edge to the center line of the couple ball socket. If this dimension is less than 12 inches, remove the foot from the trailer, or possible damage to the rear step bumper could occur.

GROSS COMBINATION WEIGHT RATING (GCWR) Includes Weight of Truck and Trailer By Engine & Axle Ratio for Recreational Applications

With Automatic Transmissions

GCWR (lbs.)	6000	6500	7500	8500	9000	9500	10,000	10,500	11,000	11,500	12,000	12,500	13,500	14,500	15,000	16,000	19,000
Engines	Rear Axle Ratios																
2.5L (151) L4 Gas	3.73	4.11															
4.3L (262) V6 Gas ¹			2.73	3.08 ¹		3.42 ¹	3.73	4.10/ 4.11	4.56								
5.0L (305) V8 Gas						3.08		3.42		3.73		4.10					
5.7L (350) V8 Gas							3.08		3.42		3.73		4.10		4.56		
6.2L V8 Diesel					3.08		3.42		3.73		4.10		4.56				
7.4L (454) V8 Gas													3.42	3.73		4.10	4.56/ 5.13 ²

With Manual Transmissions

GCWR (lbs.)	5000	5500	6000	6500	7000	7500	8000	9000	10,000	11,000	12000	13,500	14,500	15,000	16,000	19,000
2.5L (151) L4 Gas	3.73	4.11														
2.8L (173) V6 Gas	3.73															
4.3L (262) V6 Gas			2.73 ³	3.08 ³	3.42 ³	3.73										
5.0L (305) V8 Gas					3.08	3.42		3.73								
5.7L (350) V8 Gas									3.08	3.42	3.73	4.10		4.56/ 5.13 ²		
6.2L V8 Diesel					3.08	3.42		3.73	4.10	4.56						
7.4L (454) V8 Gas							4.56					3.42	3.73		4.10	4.56/ 5.13 ²

¹ GCWR with automatic transmission reduced by 1000 lbs. for S-10 Pickup with available P235/75R-15 tires. ² 5.13 rear axle ratio available for C3500 HD Chassis-Cab only. ³ GCWR with manual transmission increased by 1000 lbs. for S-10 Pickup, but by only 500 lbs. if vehicle has P235/75R-15 tires.

THE USE OF GCWRs TO DETERMINE POWERTRAIN AND REAR AXLE RATIOS.

Perhaps you prefer to use Gross Combination Weight Ratings (GCWRs) to determine the engine, transmission and rear axle ratio you will require to tow a specific trailer with your Chevy truck. The chart above allows you to do just that. It shows you the maximum allowable GCWR based on all the available truck engines and rear axle ratios with automatic or manual transmissions. The GCWR includes the total loaded weight of both the truck and the trailer. Any available engine may be used for trailering if the GCWR shown is not exceeded. The trailer weight can be 25% greater if the vehicle speed will not exceed 25 MPH.

Chevrolet takes considerable pride in its ability to provide high-quality vehicles for the growing sport of off-roading. However, as providers of such vehicles, we also share responsibility for the preservation of that which makes the very thrill of off-roading possible: the natural environment.

We share that responsibility with you, the individual off-roader. And we ask you to join with us in a "pro-

environment" attitude as you pursue the many pleasures of "four-wheeling."

As the source for many types of light-duty trucks, Chevrolet encourages you to drive at least as carefully off-road as on-road – and to do your part to help preserve the beauty of America's wildlands.

If you intend to purchase a Chevy truck and drive it



FOUR-WHEELING TIPS

off-road, there is literature available that offers excellent suggestions for safe, responsible four-wheeling. It's advice designed to protect you, your vehicle *and* the environment.

Your Chevrolet Owner's Manual clearly describes the vehicle's capabilities and limitations, plus the maintenance schedule required to keep your Chevy running

right. We strongly suggest that you thoroughly read the Owner's Manual.

Additional good ideas on responsible four-wheeling are available in the *Chevy Outdoors* magazine and other publications. Ask your Chevy truck dealer for subscription information on *Chevy Outdoors*.



CHEVROLET'S BEST WARRANTY EVER.

GM's 3-year/50,000-mile limited warranty offers a security blanket covering just about everything. Almost every part is covered, from front to back, road to roof. The limited warranty covers repairs for any new Chevrolet van or light-duty truck, including labor and parts, to correct any defects in material or workmanship occurring during the warranty period. After the first year or first 12,000 miles, whichever comes first, repairs are subject to a \$100 deductible per repair visit. Warranty features include no-cost warranty transfer, 6-year/100,000-mile body-rust-through protection, and 5-year/50,000-mile emissions control system coverage. Other warranty features include: *Air conditioning repair*. The sealed refrigerant portion of the factory-installed air conditioning system has no deductible the first year, regardless of mileage. *Towing*. If your vehicle cannot be driven because of a defect covered by warranty, towing to the nearest Chevrolet dealership is covered.

Items not covered include tires (which are covered by their manufacturers) and normal maintenance. See your Chevrolet dealer for details, including terms and conditions of this limited warranty.



NEW-VEHICLE LIMITED WARRANTY	Coverage
Bumper to Bumper Plus coverage, except tires*, less \$100 deductible after 12 months or 12,000 miles, whichever comes first	3 years/ 50,000 miles
Air Conditioning (deductible applies after one year)	1 year regardless of distance
Corrosion (rust-through) (deductible does not apply)	6 years/ 100,000 miles
Emissions Control System (deductible does not apply)	5 years/ 50,000 miles
Warranty Transfer (fully transferable to all subsequent owners)	No charge

* Tires are covered by their manufacturers.

GM PROTECTION PLAN.

The GM Protection Plan offers service protection in addition to that provided by GM's new-vehicle limited warranty. Available only in the U.S. and Canada. Ask your dealer about this option.

GMAC FINANCING.

At your Chevrolet dealer's, financing or leasing your new Chevy truck can be as easy as saying GMAC. All the new Chevy trucks may be financed through the GMAC First-Time Buyer Program, which makes it relatively easy for qualified first-time buyers to get credit. See your Chevrolet dealer for qualification details.

OUR COMMITMENT TO YOUR SATISFACTION.

Chevrolet has a complete customer satisfaction system in place to ensure your contentment with the truck you buy and the dealership that sells it to you. It's a system that begins with thorough product inspections throughout the manufacture and assembly of Chevy trucks, continues at your Chevy dealer's with a detailed pre-delivery inspection of the Chevy you select and includes follow-up activities after you've driven your new Chevy home. Chevrolet stays in touch with you, the customer, as long as you own your Chevy. For one thing, we ask for and act upon evaluations of Chevy truck performance and Chevy truck dealer performance.

Your local Chevy truck dealership is a vital link in our customer satisfaction system, and a strong one. Your dealer's salespeople will introduce you to the Chevy of your choice, explain all warranties and maintenance schedules and accompany you on an orientation drive to make sure you're thoroughly familiar with your new truck's features and operation. Equally important, your dealer's service advisors and technicians are highly trained and equipped with the most up-to-date diagnostic and repair equipment, all to help ensure your long-term satisfaction with maintenance and repair work performed on your Chevy.

When you're traveling long distances for pleasure or business, it's also comforting to know there are over 4900 Chevy truck dealers dotting the map of the U.S.A.—each one ready to provide you with professional service and genuine GM parts. What's more, you

can dial this toll-free number: 1-800-222-1020 to talk to trained experts regarding any Chevrolet product or service problem you may have. (You can call the Chevrolet Customer Assistance Center on Monday through Friday, 8:00 a.m. to 7:30 p.m., Eastern Standard Time.)

SAFETY FEATURES

Occupant Protection (Regulatory)

- Manual lap/shoulder safety belts, outboard front and rear seat positions
- Manual lap safety belts, center front/rear seat positions, where applicable
- Energy-absorbing steering column
- Energy-absorbing instrument panel
- Energy-absorbing front seat-back tops
- Interlocking door latches
- Inertia-locking, folding front seat-backs (two-door models)
- Safety armrests
- Breakaway inside rearview mirrors
- Security door locks and door retention components

(Non-Regulatory)

- Tempered safety glass, side windows and rear windows (laminated safety glass in Suburban rear-door quarter windows)
- Dual sun visors

Accident Avoidance (Regulatory)

- Side marker lamps and reflectors
- Parking lamps that illuminate with headlamps
- Four-way hazard warning flashers
- Back-up lamps
- Directional signal control with lane-change feature
- Windshield defroster, washer and multi-speed wipers
- Outside left and right rearview mirrors
- Brake system with dual master cylinder and warning light
- Starter safety switch

- Dual-action hood latch • Low-glare finish on inside windshield moldings, wiper arms and blades, and metallic steering wheel surfaces • Illuminated heater and defroster controls • Tires with built-in tread wear indicators

(Non-Regulatory)

- Inside rearview mirror
- Audible brake lining wear indicators (disc brakes)

A WORD ABOUT 1991 CHEVY TRUCK BROCHURES.

In addition to this 66-page brochure on Chevy pickups, you may wish to have the other two 1991 Chevy truck brochures.

The 72-page *Vans / Blazers / Suburbans* brochure will give you an excellent overview of Chevrolet's many personal-use light-duty trucks, beyond pickups.

The 38-page *Commercial Vehicles* brochure describes the many Chevy trucks designed specifically for hard work in business and industry.

Feel free to ask your Chevy truck dealer for one or both, depending on your needs and interests.

IMPORTANT: A WORD ABOUT THIS CATALOG.

We have tried to make this catalog as comprehensive and factual as possible. We reserve the right, however, to make changes at any time, without notice, in prices, colors, materials, equipment, specifications, models and availability. Since some information may have been updated since the time of printing, please check with your Chevrolet dealer for complete details.

A WORD ABOUT ENGINES.

Chevrollets are equipped with engines produced by different operating units of GM, its subsidiaries or suppliers to GM worldwide.

A WORD ABOUT ASSEMBLY.

Chevrollets are assembled by different operating units of General Motors, its subsidiaries or suppliers to GM worldwide. Chevrollets incorporate thousands of components produced by different operating units of GM, its subsidiaries or suppliers to GM worldwide. We sometimes find it necessary to produce Chevrollets with different or differently sourced components than originally scheduled. All such components have been approved for use in Chevrolet and will provide the quality of performance associated with the Chevrolet name. Since some options may be unavailable when your vehicle is assembled, we suggest that you verify that your vehicle includes the equipment you ordered or, if there are changes, that they are acceptable to you.

A WORD ABOUT UPDATED SERVICE INFORMATION.

Chevrolet regularly sends its dealers useful service bulletins about Chevrolet products. Chevrolet monitors product performance in the field. We then prepare bulletins for servicing our products better. Now you can get these bulletins, too. Ask your dealer. To get ordering information, call toll-free: 1-800-551-4123.

A WORD ABOUT CORROSION PROTECTION.

Chevrollets are designed and built to resist corrosion. All body sheet metal components are warranted against rust-through corrosion for 6 years/100,000 miles. Application of additional rust-inhibiting materials is not required under the corrosion coverage.

A WORD TO CUSTOMERS ABOUT BEDLINERS FOR PICKUP TRUCKS.

If you're in the market for a pickup truck, you may be considering buying an optional bedliner. Your Chevy truck dealer offers you GM's Duraliner—a tough, molded plastic unit that fits securely into the bed of the truck.

People using their trucks for hauling will enjoy the protection the liner offers against the scraping and banging of the load against the body of the truck. As owners of "working" trucks know, load hauling can take a toll on the surface of a truck bed. Bedliners take the brunt of that damage. You will also find that the liner is easy to wash out and, because it is made of plastic, it won't rust.

But bedliners may not be desirable for everyone, particularly if the truck is not used for hauling. Although the liner fits

snugly into the truck bed, it does shift slightly as the truck moves, and this shifting causes a small amount of chafing on the truck bed's painted metal surface. The resulting wear may be noticeable if and when the bedliner is removed from the truck. And, because the truck's corrosion resistance depends in part on the paint, the chafing could accelerate rust on the bed's metal surface. That rust is not covered by any GM warranties.

On balance, the potential for damage to the metal surface of the truck bed is much greater from the banging of a load directly against the metal than from the chafing of the metal by a bedliner. You should base your decision regarding the purchase of an optional bedliner on the amount of load hauling you might do with your truck, and whether you plan to remove the bedliner or not.

Chevrolet, the Chevrolet emblem, S-10, Cheyenne, Scottsdale, Silverado and Blazer are registered trademarks of the General Motors Corporation. Chevy and Insta-Trac are trademarks of the General Motors Corporation. 1990 GM Corp. All rights reserved.



Let's get it together...
buckle up.

The Heartbeat
More People Are Winning With  of America. TODAY'S TRUCK IS CHEVROLET.™

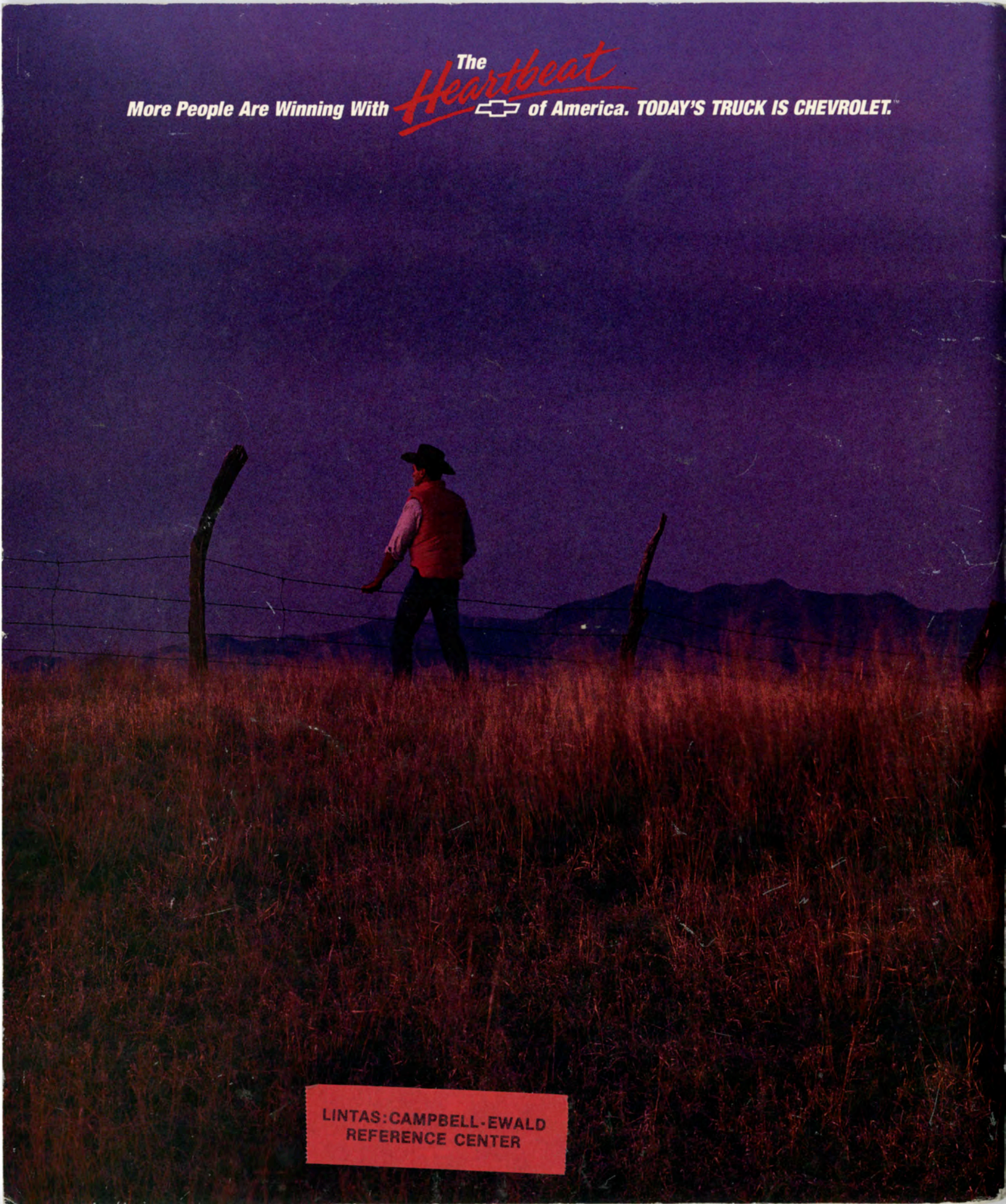

LINTAS: CAMPBELL-EWALD
REFERENCE CENTER