

2000 CHRYSLER TOWN & COUNTRY



OVER THE FIRST 75 YEARS, CHRYSLER ENGINEERING

EXCELLENCE BECAME CHRYSLER HERITAGE. Within the last

10 years, Chrysler cab-forward styling has changed the architecture of the modern automobile. Simultaneously came a fine-tuning so precise that drivers, lured by the sophisticated styling, are captured by the spirited road manners. It is that perfected bonding of engineering heritage, expressive design and exacting agility that comprises the Chrysler lineup for the year 2000. The Chrysler heritage continues: with 300M, purebred descendant of the fabled 300 letter series; with Sebring, the land's best-selling convertible; with Town & Country, the luxury culmination of 16 years of Chrysler minivan leadership; with the 2001 PT Cruiser,* breaking the barriers of conventional design *and* function. With an entire family of elegant and able-bodied offerings that propel Chrysler innovation into the millennium.





CREATED A LEGEND
THAT MOVED A GENERATION ...

IT WAS A REVOLUTIONARY MACHINE that broke new ground in technology. And it has continually moved the world forward—seven people at a time. DaimlerChrysler Corporation minivans virtually replaced the station wagon and forever transformed America's highways and streets. We made the minivan what it is today, and our 16 years of minivan leadership and innovation have consistently captured the loyalty of owners and a renowned roster of critical acclaim.

SEVENTEEN YEARS LATER,
THE REVOLUTIONARY
THINKING CONTINUES.

For the dawning of the new millennium, Chrysler Town & Country distinctively stands out as the one choice for uncompromised luxury, premium amenities and quality craftsmanship. Available in Town & Country Limited, Town & Country LXi and Town & Country LX, Chrysler's luxury minivan lineup will satisfy the

1983-84



November 2, 1983. The very first minivan rolls off the assembly line in Windsor, Ontario. The revolution begins.

1985-86



Child-protection rear door locks are introduced and quickly become an industry standard.



One of *Car and Driver's* "10Best" in 1985.



Chrysler Corporation minivans reach nearly half a million in sales. Not bad for a new category.

1987-88



Chrysler introduces its first minivan offering a V6 engine, increasing horsepower more than 42 percent.



The first long-wheelbase minivan debuts, allowing for not only more cargo space, but more leg room.

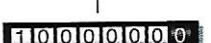

Over 1,000,000 Chrysler Corporation minivans sold.

1989-90



The first luxury minivan debuts. The ultimate minivan: Chrysler Town & Country.

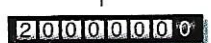

2,000,000 Chrysler Corporation minivans sold.



First adaptive transaxle is launched. The system is capable of maintaining smooth shifts throughout a vehicle's life.

1991



Chrysler becomes the first company to put a driver's side air bagSM in a minivan.



Town & Country is the "#1 Minivan in Customer Satisfaction," according to J.D. Power and Associates.SM

1992



The first-ever Integrated Child SeatsSM debut, providing greater security and convenience.



Town & Country is named *Motor Trend's* "Best of the USA."

lines and exact needs of the most discriminating luxury purist. And

2000, every Town & Country features an extended

base for even more cargo versatility, comfort and room. Plus,

re's the road-gripping advantage of available all-wheel drive

every Town & Country model. A feature you'll really want.

ed on the premise that luxury is a necessity, everything about

new 2000 Chrysler Town & Country is designed to meet your

ectations. After all...

e luxury and comfort say a lot about Town & Country.

e craftsmanship and quality say a lot about you.

RYSLER TOWN & COUNTRY WAS AWARDED:

tomobile Magazine All-Star winner four years in a row.⁽¹⁾



1994



Chrysler minivans are the first American minivans with standard dual front air bags² five years before government requirements.



Our minivans are also the first with dynamic side-impact protection — yet another blow to the competition.



Over 4,000,000

1995



Prevention Magazine names Town & Country "Safe Car of the Year."



Town & Country wins "First for Safety" award from Kiplinger's.

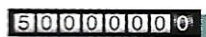

5,000,000 Chrysler Corporation

1996



Next generation of minivan debuts with the exclusive driver's side sliding door.



Town & Country wins Strategic Vision's Total Quality AwardTM for "Best Ownership Experience" in minivans.⁽⁵⁾



Town & Country is

1997



Town & Country has the "Best Resale Value," according to Kiplinger's.



Town & Country ties as J.D. Power and Associates' "Most Appealing Minivan."⁽⁶⁾



Town & Country wins

1998



1998 marks the 15th anniversary of the minivan and Chrysler still leads the way.



The new Town & Country Limited debuts. It's the most luxurious minivan ever.



7,000,000 DaimlerChrysler minivans sold and still





TOWN & COUNTRY LIMITED

NO LIMIT TO THE LUXURY. Limited is the ultimate Town & Country, replete with an array of heightened luxury features. With 3.8-liter V6 power, effortless handling and available all-wheel drive, it has the superior engineering you expect from Chrysler's heritage of continuous refinement. With inviting Preferred Suede® appointments, leather-trimmed seven-passenger seating and power heated eight-way



driver and front-passenger seats, it has enough luxury to complement a black tie charity event. And with its uncompromised dedication to craftsmanship, displayed in chrome door handles and distinctive wood instrument cluster graphics, Town & Country Limited is destined to be desired by all—but possessed by only those individualists who insist on the perfection of sumptuous luxury.



TOWN & COUNTRY LXi

LUXURY THAT SPEAKS IN AN UNPRETENTIOUS VOICE. Chrysler Town & Country LXi is a minivan of sophistication, engineering excellence and premium comfort. Picture motoring to your next weekend getaway in command of LXi's available powerful 3.8-liter V6, with the convenient available load-leveling suspension system, eight-way power driver and front-passenger seats, Dual Zone Temperature Control



h rear air conditioner/heater, steering wheel audio controls and the impressive acoustics that make the
nity Acoustic 10™ Sound System endearingly beautiful to the ears. And to handle just about any road
dition, there's available all-wheel drive. Plus, accessibility will never be an impasse, because LXi—like
ery Town & Country model—features a standard driver-side sliding door.



TOWN & COUNTRY LX

NOT ONLY LUXURIOUS AND VERSATILE, TOWN & COUNTRY LX is the definitive choice for drivers who prefer to choose their own blend of luxury refinements. The roomy, long-wheelbase LX is furnished with all the expected standard features—power heated exterior mirrors, seven-passenger seating with intermediate Quad Command buckets and driver-side sliding door. Plus a diversity of options—such as all-wheel drive with



liter V6 power—that lets you personalize the balance of luxury that's perfect for you. New for 2000,
features standard 15-inch tires, 15-inch Rallye wheel covers, AM/FM stereo radio with cassette player,
and body-color bodyside molding.





Overhead console contains an assortment of useful information and driver aids.⁽²⁾



THE REWARDS OF TOWN & COUNTRY LUXURY can be found everywhere...An ultra-comfortable **eight-way adjustable power driver's seat**⁽¹⁾ (left center) allows two drivers to preprogram settings. For even more custom comfort, the driver's seat has adjustable lumbar support. Both front leather-trimmed bucket seats⁽²⁾ are equally adjustable (including recliner feature) via actuators shaped for an instinctive "feel." There's also the welcoming warmth of **heated seating surfaces**⁽²⁾ on the driver and front-passenger seats. AM/FM stereo with cassette and CD player⁽³⁾ (top right) features easy-to-access control of all functions. A remote keyless entry system⁽⁴⁾ includes illuminated entry, controls for power door locks and more. **Electrochromic inside rearview mirror**⁽⁵⁾ (left top) automatically dims the reflection of bright headlamps from following cars. Dual Zone Temperature Control⁽⁶⁾ (not shown) provides precise comfort settings for driver and front passenger. Convenient and efficient area-specific heating and air conditioning keeps rear-seat passengers contented.⁽³⁾ A **lockable side-of-seat compartment**⁽⁷⁾ (left) is one of many thoughtful storage areas. Combine this bounty of luxury with the confidence of Chrysler's full-time all-wheel drive⁽⁸⁾ and you'll discern why the Town & Country driving experience can only be described as *exceptional*.

⁽¹⁾8-way power driver seat standard on all Town & Country models, memory feature is standard on Limited and available on LXi. ⁽²⁾Standard on Limited, optional on LXi. ⁽³⁾Standard on Limited, optional on LX and LXi. ⁽⁴⁾Standard on LXi and Limited, optional on LX. ⁽⁵⁾Standard on Limited. ⁽⁶⁾Standard on all Town & Country models. ⁽⁷⁾Standard on Limited, included with passenger-side power seat on LXi. ⁽⁸⁾Available on all Town & Country models. ⁽⁹⁾Standard on LX and LXi.



Limited's standard cassette/CD player and Infinity Acoustic 10™ Sound System delivers outstanding sound.



Near-at-hand under-seat storage drawer conveniently holds small items.⁽⁹⁾



Cup holders

TOWN & COUNTRY VERSATILITY

"PRACTICAL AND FUNCTIONAL LUXURY" is a term seldom applied to luxury sedans. Today's active lifestyles demand qualities such as versatility, capability, and ample cargo space. While luxury automobiles may be significantly deficient in these aspects, Chrysler Town & Country has the unique ability to satisfy both luxury needs and practical desires.

Multiposition seat recliners, along with three-position fore-and-aft adjustment for the rear bench, provide accommodation to personal preference, even in seven-passenger configurations. In fact, there are many seating configurations (bottom), and the rear seats can be folded for increased cargo capability when it's not convenient to remove and leave them behind. Versatile Quad Command seats are standard on every Town & Country, and the sheer grace and comfort of **leather-trimmed seats** are standard on Limited, optional on LXi. Bench **Easy Out Roller Seats**® (right) make the conversion from rear-seating to cargo-carrying an uncomplicated effort. Eight rollers glide the bench seat as it is unlatched, and molded tracks in the floor guide the seat and reduce resistance to rolling. And **ease of entry** to the area behind the rear bench is made more accessible with a wide, tall liftgate. Plus, a durable **scuff pad** is standard on all models to help protect the rear bumper upper surface when loading or unloading cargo.



Standard easy-entry intermediate bucket seats exemplify Town & Country's attention to interior details.

Easy Out Roller Seats® are simple to handle and operate.

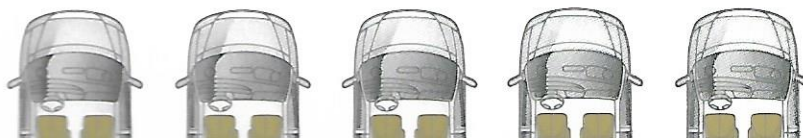
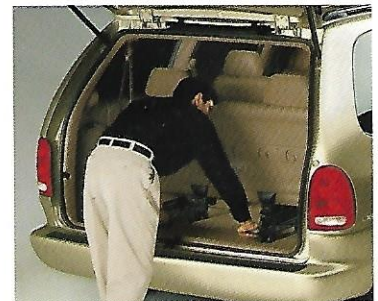

A wide variety of seating arrangements



LXi's analog instrument cluster provides key information at a glance.

THE RAREFIED AIR OF LUXURY AND ERGONOMIC

PERFECTION. Attention to details. The feel of a knob and a switch. The elegance of quality materials. A **leather-wrapped steering wheel*** in your hands. The look of craftsmanship. An instrument panel predisposed to the driver. This is luxury that creates a unity—not a barrier—between driver and minivan. This is the inherent luxury of Town & Country Limited's instrumentation. Engaging looks are enhanced by **unique instrument cluster graphics** and handsome **woodgrain-appearance trim.** Beautiful to the eye. Inviting to the touch. This is hands-on luxury. Nothing is beyond your reach.

*LXi and Limited models only.

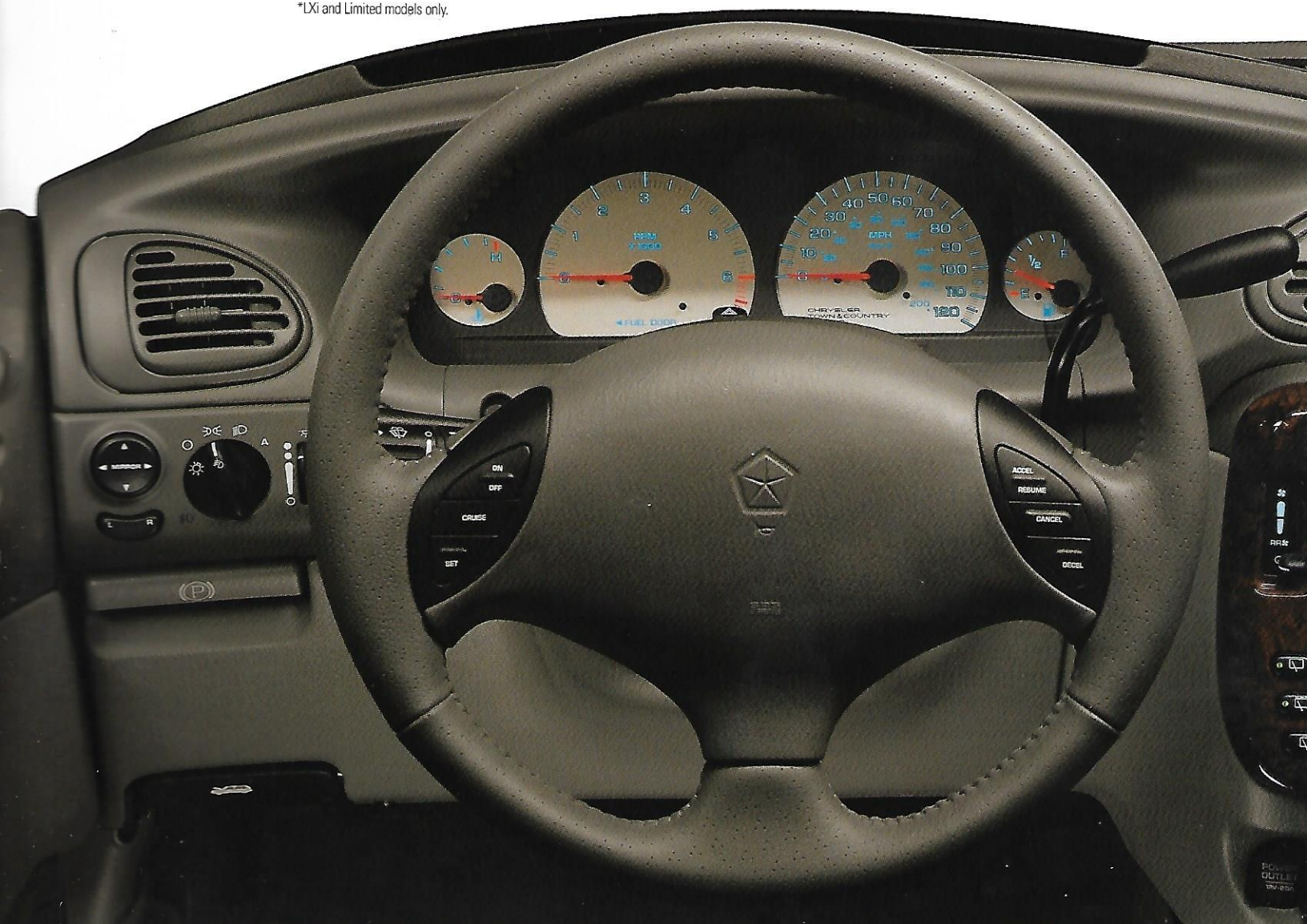



Umbrella holder accommodates most parasols.



Chrome door handles contribute a look of elegance.

THE FEATURE-RICH TOWN & COUNTRY LIMITED

offers many exclusive luxury enhancements: Appealing **Preferred Suede® interior appointments** (shown pages 18-20) enrich Limited's leather-trimmed seven-passenger seating that includes **heated surfaces on front seats**. 18-ounce carpeting is thick and plush. **Steering wheel radio controls** offer close access to the Infinity Acoustic 10™ Sound System. **"Limited" logo floor mats** enhance the interior. Special **"Limited" badging** adds a sophisticated touch to Limited's contemporary cab-forward styling. The concern for details. It's very evident in Town & Country Limited.



Rear-bench seat design with integral head restraints and center armrest.

For a complete listing of Limited's luxury features, please see pages 28-29.



TOWN & COUNTRY CONVENIENCE



An ultra-efficient ventilation system allows air to flow completely throughout the interior.

CLEARLY A NICE PLACE TO GET COMFORTABLE.

The conveniences of a luxury automobile are engineered right into Chrysler Town & Country, as are the capacities of a special-purpose vehicle. Similar to a luxury sedan, heating and cooling are directed through outlets located in the rear—and fan speed can be adjusted front or rear.* **Area-specific lighting** is thoughtfully positioned, including roof rail reading lamps that provide focused, nonglare lighting that won't distract others. Liftgate flood lamps make loading cargo at night much easier. **Solar-control glass** makes the ride much more comfortable for passengers, and helps protect the interior from harmful sun radiation. The voluminous interior **caters to recreational gear** of all sorts, including skis, which can be carried beneath the rear seats without removing or rearranging anything. And when these numerous refinements are incorporated into Town & Country Limited, for example, you have an interior cabin (opposite pages) that composes a perfect symmetry between convenience, comfort and spacious room. Opulence never looked—or felt—so nice.



Internal wiring system quickly and efficiently heats Town & Country's front bucket seats!



Dual Zone Temperature Control for driver and front-seat passenger.



Standard cargo net between the front bucket seats keeps items close at hand.

*Standard on Limited, included with optional rear heater and air conditioner on LX and LXi.
†Standard on Limited; optional on LXi with leather-trimmed seats.









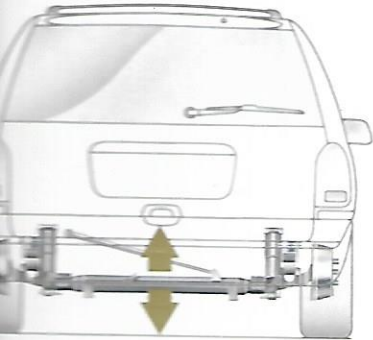

Load-leveling
suspension
automatically
adjusts vehicle
attitude.

THE MOST ADVANCED TOWN & COUNTRY TO DATE.

Take a moment to look under the hood. The standard **180-horsepower 3.8-liter V6*** in Limited, and the standard **158-horsepower 3.3-liter V6** in LX and LXi combine excellent fuel efficiency, high power output and Chrysler's well-known reliability. Both incorporate some of the best and most advanced automotive technology in the world today. Add the available **Trailer Tow Prep Group** and available Mopar hitch receiver, and the 3.8-liter V6* can tow up to 3,500 pounds. And for even more versatility along the highways and byways, the 3.3-liter V6 engine features flex fuel (ethanol) capability.† Beneficial **load-leveling rear suspension†** system automatically adjusts Town & Country's attitude for a smooth and even vehicle stance, no matter the load. Tomorrow's technology today is what awaits in every 2000 Chrysler Town & Country.

*Optional on LXi FWD models. Standard on all AWD models.

†Flex fuel (ethanol and/or unleaded gasoline) capability not available in CA, MA, NY or VT.

‡Standard on AWD models and Limited; optional on LXi and LX.

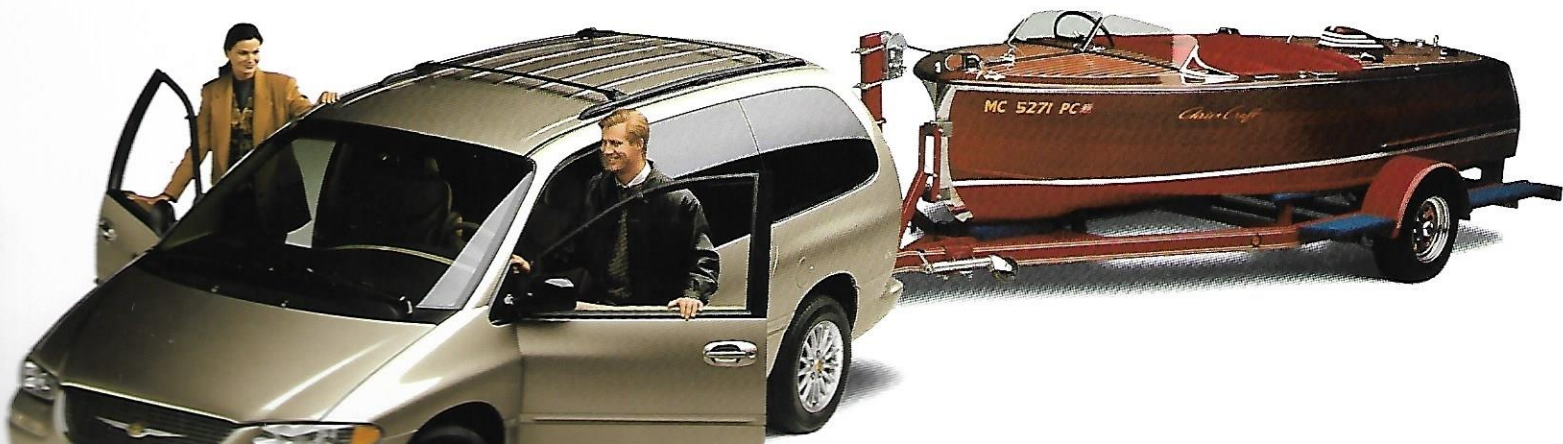

TOWN & COUNTRY STRUCTURE

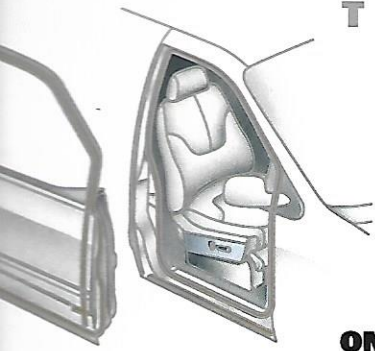

Doors have barriers to help block the intrusion of exterior noise.

ONE OF THE NICEST ATTRIBUTES of luxury is its unrelenting drive for quietness. Town & Country's liftgate and doors receive special attention to block out the traffic's roaring boom. **Sound-Loc door liners and door seals** (above left) perform with the trim panels to reduce noise inside door cavities. A wide variety of absorbers, barriers and dampers suppress sounds that would otherwise intrude upon the harmonious tunes emanating from Town & Country's available Infinity Acoustic 10™ Sound System. Advanced **Unibody construction** provides a car-like ride, and its exceptional torsional stiffness lessens the potential for annoying buzzes, squeaks and rattles. Here are five more techniques that help make Chrysler Town & Country so **luxuriously quiet**: double-layer dash panel silencers are installed on both sides of the dash to muffle engine noise (1); intra-pillar (2) and sill baffles (3) soften road noises; dampers subdue vibrations in large panels such as the floor pan (4); porous absorber pads inserted behind trim panels (5) absorb exterior noise.

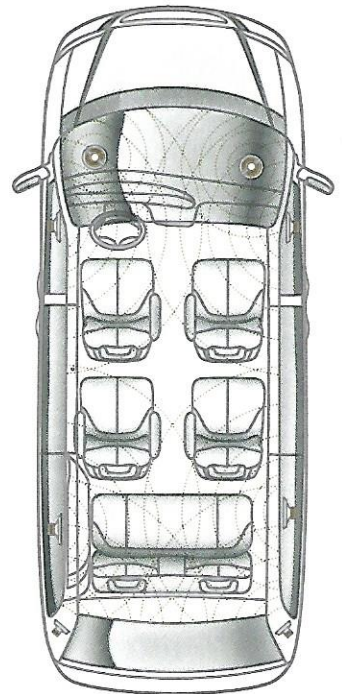

Town & Country's ultra-quiet atmosphere enhances the sound system.

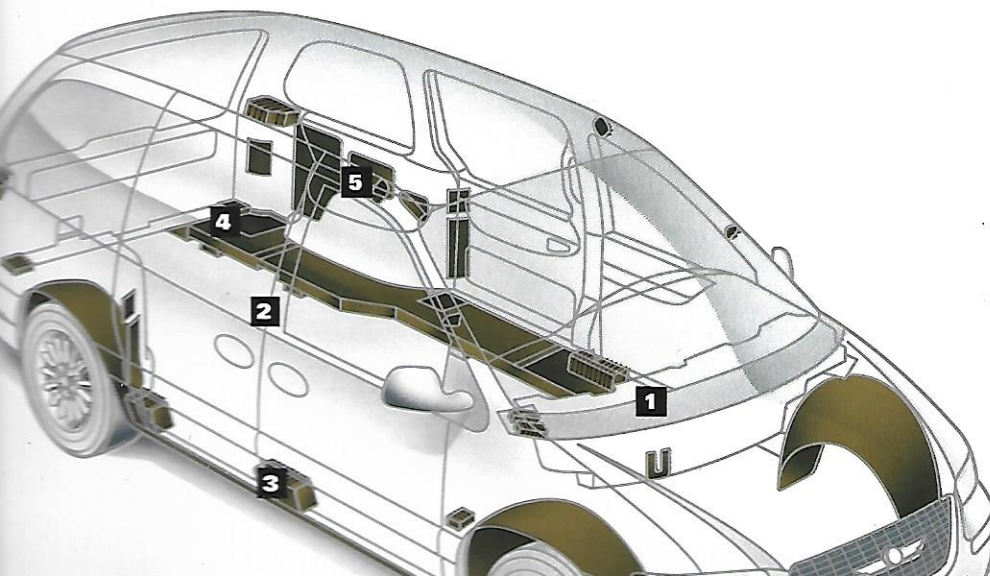

TOWN & COUNTRY ALL-WHEEL DRIVE

ALL-WHEEL DRIVE is available on all 2000 Town & Country models for directional stability and confident steering in inclement driving conditions. Not intended for off-road usage in the wild, this full-time system makes use of a unique viscous coupling to apply the power to the front or rear wheels—depending on where it is needed most. In normal driving conditions on dry roads, Town & Country all-wheel drive directs most of its driving power to the front wheels. This is one feature you'll definitely want on your Town & Country.





Surefooted traction is what Town & Country all-wheel drive contributes—in severe weather driving conditions, and on any kind of road surface. Surer, straighter starts at slippery intersections become the standard with all-wheel drive. And control is better maintained to navigate icy corners and to handle snow-covered curves. All-wheel-drive models include the safety of four-wheel disc antilock brakes.



ALL-WHEEL DRIVE

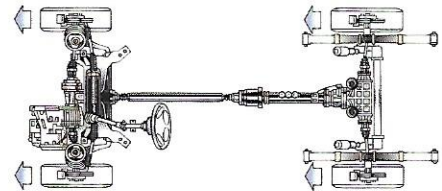

FRONT-WHEEL DRIVE

ALL-WHEEL DRIVE

SLICK ROAD CONDITIONS COULD MAKE MANEUVERABILITY MORE DIFFICULT

POSSIBLE LOSS OF STEERING CONTROL

DECREASED TRACTION COULD RESULT IN SPIN-OUTS ON ICY ROADS

HELPS MAINTAIN DIRECTIONAL STABILITY

HELPS TO CONTROL STEERING

ROAD-GRIPPING TRACTION HELPS MANEUVER ICY ROAD BENDS

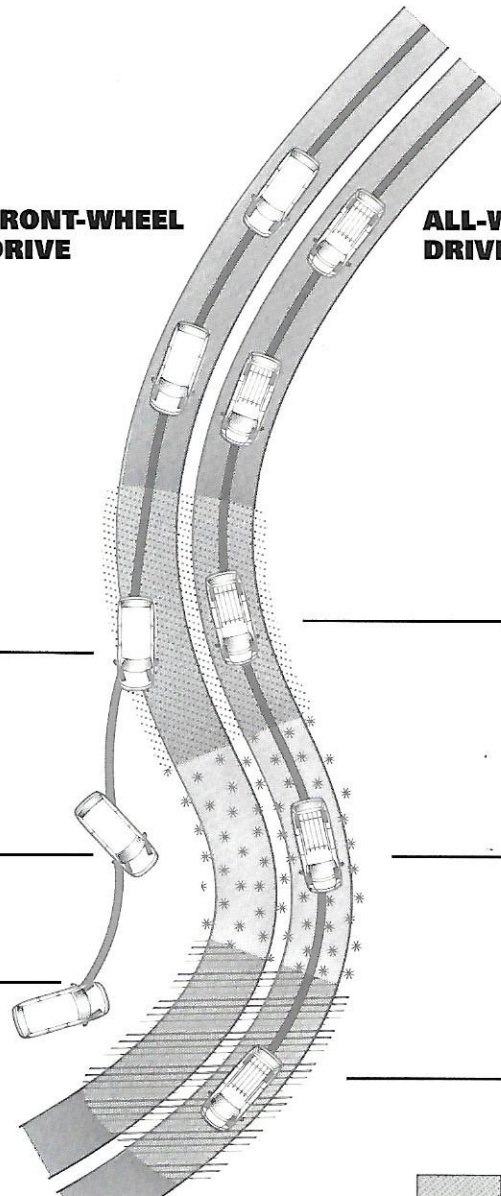

EVERY CHRYSLER TOWN & COUNTRY is scrupulously designed and engineered to help maximize the protection of every occupant. After all, aren't peace of mind and safety truly the most important automotive luxuries? Next Generation driver and front-passenger air bags* are standard on every Town & Country model. **Available all-wheel drive** offers directional stability and confident steering control (see pages 24-25 for more details). And DaimlerChrysler endorses **Do The Buckle!**, a national consumer safety campaign designed to educate children—as well as all people who drive or ride in vehicles—on the importance of wearing seat belts. Available Integrated Child Seat† (above right) features a multiposition reclining seatback, and is located in the passenger-side intermediate Quad Command bucket seat‡ **Comfort-Fit Seat Belt System™** encourages usage with multiheight-adjustable shoulder belts§ and traveling seat belt buckles. Available **traction control** (standard on Limited and optional on LXi models) senses over-spin on the front driving wheels and applies braking power for better grip at speeds up to 35 mph. **Vehicle Security System**¶ is armed when the power doors are locked.

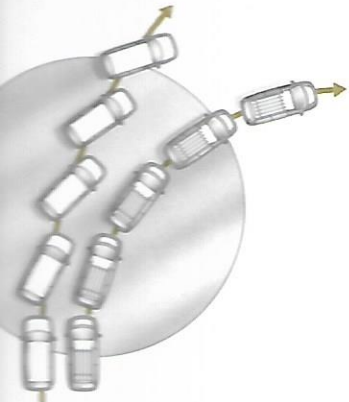

Four-wheel antilock brakes (ABS) are standard on all Town & Country models.

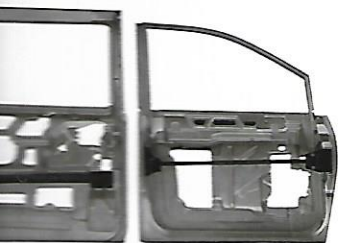

Side-guard door beams help provide protection in side-impact collisions.



Available Integrated Child Seat† helps keep a young traveler secure.

ADDITIONAL SAFETY FEATURES

- Center high-mounted rear stoplamp
- Child-protection lock on sliding side doors
- Energy-absorbing front seatbacks
- Energy-absorbing steering column
- Fade-resistant front vented disc brakes
- Fog lamps
- Hazard-warning flasher system
- Head restraints and shoulder/lap belts for all outboard seating positions
- Ignition and steering column lock
- Knee blockers
- Nonglare interior lighting
- Positive lock on automatic transaxle prevents shift out of gear when ignition switch is in the off position
- Safety-rim wheels

*Certified to the Federal Regulations that allow less forceful air bags. Always use seat belts. Remember a backseat is the safest place for children.

†For children at least one year old, weighing between 22 and 50 pounds and no more than 47 inches tall.

‡Optional on LX, LXi and Limited.

§At front and intermediate outboard seating positions.

¶Standard on Limited, optional on LX and LXi.

TOWN & COUNTRY QUALITY



CHRYSLER TOWN & COUNTRY IS SIMPLY A WONDER

of technical and design virtuosity—a feeling worth experiencing. Chrysler engineers and designers know that there's only one criterion of any real importance in the designing of a quality luxury minivan: **enhancing the enjoyment of motoring**. The world's finest luxury minivans are all conceived and engineered at the dramatic DaimlerChrysler Technology Center in Auburn Hills, Michigan. From initial styling and prototype development through countless hours of testing, Chrysler designers and engineers create and refine each product until it meets our **stringent expectations** for quality, performance and reliability. Because, you see, Chrysler doesn't believe in offering just the standards. Chrysler believes in setting them and then **exceeding** them.

Classically designed grille is adorned with a distinctive winged medallion reminiscent of the original Chryslers of 1924.



All Town & Country models include:

- Air Bags** — Next Generation driver and front-passenger*
- Air Conditioning** — Front (CFC-free) with manual Dual Zone Temperature Control, Mid-Cabin Comfort Control, includes heater and vent/air conditioning outlets in rear of front door trim panels
- Assist Straps** — Front-passenger seatback, driver seatback
- Brakes** — Antilock Brake System, four-wheel
- Climate Group** — II, Sunscreen/solar-control glass
- Console** — Overhead with mini-trip computer, compass, temperature, sunglasses and garage door opener holder
- Convenience Group**
 - I, Speed control, tilt steering column and power exterior mirrors
 - II, Convenience Group I plus power door locks
 - III, Convenience Group II plus power windows and vents
- 14 Cup/Juice Box Holders**
- Defroster** — Electric rear window
- Demisters** — Front side windows
- Door Locks** — Power, front, sliding and liftgate, child-protection rear (sliding doors)
- Doors** — Driver- and passenger-side sliding
- Dynamic Side-Impact Protection** — Steel side-guard door beams and structural reinforcements
- Fuel Door** — Driver-side, with interlock feature on driver-side sliding door
- Fuel Tank** — 20-gallon, tethered fuel cap
- Grocery Bag/Utility Hooks** — Rear seatback
- Instrument Cluster** — Analog, full-gauge with tachometer
- Light Group** — Ignition time delay, glove box, ashtray
- Lighting**
 - Exterior — Quad headlamps, halogen with park/turn/side marker lamps and built-in manual adjuster with leveling device; three-bulb taillamp, stoplamp, turn signal, side marker and back-up functions
 - Fog lamps
 - Interior — Front, courtesy/reading lamps integrated with overhead console
 - Intermediate, courtesy/reading lamps
 - Rear, dome, cargo, liftgate, dual floodlamps

- Map Pockets** — Front doors and front passenger-side seatbacks
- Mirrors** — Illuminated visor vanity
- Multifunction Control Lever** — Includes controls for turn signals, headlamps, lane-change feature, optical horn, instrument panel dimmer, windshield wipers/washers, pulse wipe
- Power Outlets** — Front and rear, 12V DC with tethered covers
- Seat Belts** — Color-keyed, Comfort-Fit Seat Belt System,TM height-adjustable shoulder belts and traveling seat belt buckles for front- and intermediate-row outboard passengers, single Unibelt for third-row outboard passengers and lap belt for inboard passenger, all belts made with Super-Soft webbing
- Seats**
 - Front — Bucket seats with reclining seatbacks and folding inboard armrests
 - Driver-side manual lumbar support
 - Eight-way power driver's seat
 - Rear — Seven-passenger deluxe trim with intermediate Quad Command bucket seats and three-passenger rear bench seat
 - Easy Out Roller Seats[®] (bench seat only)
- Speed Control** — Electronic with steering wheel-mounted controls
- Steering** — Power-assisted rack-and-pinion
- Steering Column** — Tilt
- Storage** — Bin instrument panel center console
- Bins, rear covered armrest
- Sun Visors** — With sunshade extensions
- Underhood Service Points** — Yellow with black lettering
- Windshield Wiper De-Icer** — Patented
- Wiper System** — Liftgate, continuous and intermittent with vehicle speed-sensitive intermittent mode
- Windshield, two-speed with vehicle speed-sensitive intermittent mode

*Certified to the Federal Regulations that allow less forceful air bags. Always use seat belts. Remember a backseat is the safest place for children.

FEATURES, OPTIONS AND PACKAGE GROUPS

Engine	Transmission	LX	LXi		Limited
3.3-Liter SMPI V6 FWD ¹⁾	4-Speed Automatic	28N	28R		
3.3-Liter SMPI V6 FFV FWD ²⁾	4-Speed Automatic	25N	25R		
3.8-Liter SMPI V6 FWD	4-Speed Automatic		29R	29Y	29Z
3.8-Liter SMPI V6 AWD	4-Speed Automatic	29N	29R	29Y	29Z
Air Conditioning — Rear with intermediate controls (included with Climate Group III or Value Plus Popular Equipment Group)		P	P	●	●
Assist Handle — A-pillar-mounted for front passenger				●	●
Battery — 500-ampere		●	●		
— 600-ampere (included with 3.8L engine) (standard on AWD models)		P	P	●	●
Brakes — Power-assisted front disc/rear drum (FWD models only)		●	●	●	●
— Power-assisted four-wheel disc (AWD models only)		●	●	●	●
Climate Group — III, Rear heater/air conditioner (included with Value Plus Popular Equipment Group)		O	P	●	●
Convenience Group — IV, Remote keyless and illuminated entry		O	●	●	●
— V, Convenience Group IV plus vehicle security alarm		O		●	●
— VI, Convenience Group V plus HomeLink [®] Universal Transceiver			O	●	●
Door Handles — Body-color		●	●	●	
— Chrome					●
Engine Block Heater		O	O	O	O
Floor Covering — Full-length carpeting		●	●	●	
— Plush 18-ounce full-length carpeting					●
Floor Mats — Front and rear		●	●	●	

	LX	LXI		Limited
	N	R	Y	Z
Exterior Mirrors — Exterior Power, heated, folding	●	●		
Exterior Mirrors — Exterior Power, heated, folding with memory feature (includes auto-dimming driver mirror on Limited)			●	●
Interior Rearview day/night	●	●	●	
Interior Rearview Automatic rearview day/night				●
Rack — Black	O	O	●	
Rack — Body-color				●
Seating — Fabric Wilmington premium cloth trim	●	●		
Seating — Fabric Wanderer leather trim (not available with Integrated Child Seat)			●	
Seating — Fabric Wanderer leather trim with Tri-Star perforated leather insert and Preferred Suede® trim				●
Seating — Fabric Heated front seating surfaces			O	●
Seating — Fabric Driver-side memory feature			●	●
Seating — Fabric 8-way power front-passenger seat			●	●
Seating — Fabric 7-passenger deluxe with intermediate Quad Command bucket seats with Integrated Child Seat® and 3-passenger rear bench seat	O	O		O
Seating — Fabric Driver's Group — Front and intermediate ashtrays and lighter	O	O	O	O
Sound System — AM/FM stereo radio with cassette and 4 speakers	●			
Sound System — Infinity Acoustic 10™ Sound System with AM/FM stereo radio with cassette and graphic equalizer		●		
Sound System — Infinity Acoustic 10™ Sound System with AM/FM stereo radio with cassette, CD player and graphic equalizer (Included in Value Plus Audio Group or Value Plus Popular Equipment Group)	P	P	●	●
Steering Wheel — With audio controls			●	●
Storage — Drawer, underseat (front passenger) with lock (not included in vehicles with power front-passenger seat)	●	●		
Storage — Bin, locking, inboard side of power front-passenger seat			●	●
Suspension — Fully independent front suspension with MacPherson struts and monoleaf rear springs(multileaf on AWD models)	●	●	●	●
Suspension — Heavy-duty (included in Loading Group, Trailer Tow Prep Group and Wheels/Handling Group)	P	P	P	P
Suspension — Load-leveling (standard on AWD models)	O	O	O	●
Tires — P215/65R15 BSW all-season	●			
Tires — P215/65R16 LBL all-season	O	●	●	●
Tires — Spare, compact	●	●		
Tires — Spare, full-size	O	O	●	●
Traction Control — Low-Speed (not available on AWD models)		O	●	●
Trailer Tow Prep Group — Includes 600-amp battery, 125-amp alternator, heavy-duty suspension and full-size spare tire	O	O	O	O
Value Plus Audio Group — Includes Infinity Acoustic 10™ Sound System with AM/FM stereo radio with cassette, CD player, and graphic equalizer	O			
Value Plus Popular Equipment Group — Includes rear air conditioning with intermediate controls, Infinity Acoustic 10™ Sound System with AM/FM stereo radio with cassette, CD player, and graphic equalizer and 16" Medallion cast aluminum wheels		O		
Vehicle Security Alarm	P	P	●	●
Wheels/Handling Group — Includes heavy-duty suspension, front and rear stabilizer bars, tires - 215/65R16 LBL and 16" Medallion aluminum wheels (FWD only)	O	O		
Wheels/Wheel Covers (set of 4) — 15" steel with Rallye wheel cover	●			
Wheels/Wheel Covers — 15" steel with Factor wheel cover		●		
Wheels/Wheel Covers — 16" Medallion aluminum (Included with Value Plus Popular Equipment Group)	O	P	●	
Wheels/Wheel Covers — 16" Medallion chrome aluminum				●

Legend: P = Available within package noted in parentheses. O = Optional.
 Available in CA, MA, NY and VT.
 Available in CA, MA, NY or VT.
 Intended for use by children at least one year old, weighing between 22 and 50 pounds and no more than 47 inches tall.

You would like to discuss vehicle details or pricing with a knowledgeable advisor before visiting

MEASUREMENTS



FRONT TRACK:
63.0"
OVERALL WIDTH:
76.8"



WHEELBASE:
119.3"
OVERALL LENGTH:
199.6"



REAR TRACK:
64.0"

MEASUREMENTS

EXTERIOR

Overall Height68.7"
Overall Width76.8"
Overall Length199.6"
Wheelbase119.3"
Front Track63.0"
Rear Track64.0"

TOWN & COUNTRY LX/LXi/LIMITED

SPECIFICATIONS

LENGTH

— Cargo compartment at floor

WIDTH

— Cargo compartment between wheelhousings

CARGO VOLUME

— 7-passenger seating

— Rear seats removed

TOWN & COUNTRY LX/LXi/LIMITED

EXTERIOR COLORS/INTERIOR COLORS⁽¹⁾



Emerald Green Metallic
Interior: Silver Fern,² Camel, Taupe³ 1, 2, 3



Bright Silver Metallic
Interior: Mist Gray, Taupe³ 1, 2, 3

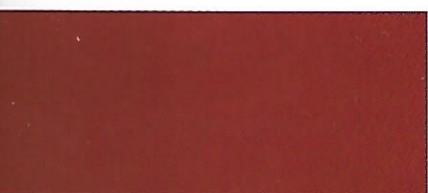

Crimson Red Metallic Tint
Interior: Mist Gray, Camel, Taupe³ 1, 2, 3



Patriot Blue Pearl Coat
Interior: Mist Gray, Camel 1, 2



Ivory White Pearl Tri-Coat
Interior: Mist Gray, Silver Fern,² Camel, Taupe³ 2, 3

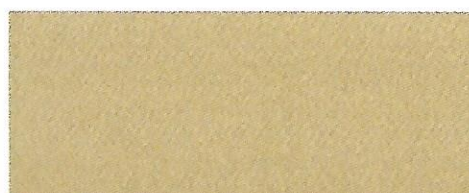

Champagne Pearl Coat
Interior: Camel, Taupe³ 1, 2, 3



Slate Pearl Coat 1, 2, 3



Bright White 1

FABRICS



Wanderer leather with TriStar Perforations shown in Taupe.



Wanderer leather shown in Camel. Also available in Mist Gray.



Wilmington premium cloth shown in Silver Fern. Also available in Mist Gray and Camel.

CHRYSLER ACCESSORIES FROM MOPAR

Every Chrysler accessory from Mopar is thoroughly designed for exceptional fit and quality, and will integrate perfectly with your



2000 Town & Country minivan. **Rear Seat Video*** lets rear-seat passengers enjoy their favorite movies or video games on long trips. Includes a video cassette player, and audio that can

be accessed through the vehicle's sound system and/or through wireless headphones. There's also a **Six-Disc CD Changer** which mounts conveniently in a unique dash console and operates from

integrated CD changer controls on RBN premium cassette radios. You

can add Mopar **Floor Mats** to keep everything clean underfoot. And

don't forget Mopar's **Molded Style Running Boards, state-of-**

the-art Sound Systems, and Front-End Covers. There are myriad

ways to enhance and protect

your new Chrysler Town &

Country. See your dealer for

brochure.

© Chrysler Winter 1999



WHEEL TREATMENTS



16-inch Rallye wheel cover (Set of four; standard on Town & Country LX.)



16-inch Factor wheel cover (Set of four; standard on Town & Country LX.)



16-inch Medallion cast aluminum wheel (Set of four; optional on Town & Country LX and LX.)



16-inch Medallion chrome aluminum wheel (Set of four; standard on Town & Country Limited.)

SOUND SYSTEMS



FM stereo radio with cassette player, graphic equalizer and Infinity Acoustic 10[®] Speaker System. (Standard on Town & Country Limited models. Optional on Town & Country LX and LX models.)



FM stereo radio with cassette player and graphic equalizer.



AM/FM stereo radio with cassette player and graphic equalizer. (Standard on Town &

CUSTOMER ONE CARE™

At DaimlerChrysler Corporation, our commitment to complete customer satisfaction is evident in every car and minivan we sell. Long after a vehicle is driven away from the showroom, we will be there to ensure that our customers remain pleased with every new-vehicle purchase. To prove this commitment, all Chrysler vehicles are covered by the 3/36 Customer One Care Plan,* which includes a 3-year/36,000-mile (whichever comes first) Bumper-to-Bumper Limited Warranty[†] and Roadside Assistance[‡] for 3 years or 36,000 miles. Roadside Assistance provides 24-hour, 7-day-a-week Emergency Road Service, contacted by a nationwide toll-free number. A 5-year or 100,000-mile Outer-Panel Rust-Through Limited Warranty covers the cost of all parts and labor needed to repair exterior sheet metal panels if perforated by corrosion. The 3/36 Customer One Care Plan stays with the vehicle, transferring automatically to subsequent owners at no cost during the warranty period.

*See your dealer for additional details and a copy of this limited warranty.

[†]Covers the complete vehicle against defects in materials and workmanship. Excludes wiper blades, clutch disc and brake linings, brake rotors and drums, normal maintenance items (these items are covered against defects for 12 months or 12,000 miles, whichever comes first) and tires (covered by their own manufacturer's warranty).

[‡]Roadside Assistance services are provided by Cross Country Motor Club, Inc. (In California, Cross Country Motor Club of California, Inc.)

LEASING

Leasing is a popular way to finance a new vehicle, and the **Gold Key Lease** offered by Chrysler Financial Company L.L.C. has the flexibility to fit your vehicle choice and your lifestyle. Lease payments are typically lower and for a shorter term than conventional financing. At lease end, you can: 1) turn the vehicle in and lease a new one; 2) buy the vehicle and keep it; 3) buy the vehicle and sell it for a possible profit. If the idea of driving the vehicle you want and paying less for it sounds great, ask your dealer about Gold Key Lease. **Gold Key Plus** is a great alternative to leasing for customers who want low payments and pride of vehicle ownership — Gold Key Plus offers both. Decide how long the vehicle will be driven and the trade-in value is guaranteed (less excess mileage and wear and tear). Ask your dealer for complete details. **Commercial Finance Options (CFO)** offers several finance and lease options to small and midsize businesses, municipalities and small fleet operators. A full range of automotive financing is available through Chrysler Financial, providing flexible payment plans and finance products for qualified buyers. Many of these plans can be customized to fit your particular budget and make your new vehicle even more affordable. The **College Graduate Program** is especially attractive to those just beginning their careers. Ask your salesperson for details about any of the above plans.

Chrysler Financial Company L.L.C. programs are offered subject to availability and state and local laws.

DAIMLERCHRYSLER SERVICE CONTRACTS

Additional protection for owners is available through optional DaimlerChrysler Service Contracts. These service plans are available in a variety of time and mileage combinations to meet your driving needs. Ask your dealer for more information or call 1-800-442-2666.

All product illustrations, specifications and competitive comparisons are based upon current information at the time of publication approval. Although descriptions are believed correct, complete accuracy cannot be guaranteed. DaimlerChrysler Corporation reserves the right to make changes at any time, without notice or obligation, in prices, specifications, equipment, colors and materials, and to change or discontinue models. Some of the equipment shown or described throughout this catalog is available at extra cost. See your dealer for the latest information.

Mopar, EVS II, Easy Out Roller Seats, Sentry Key and Customer One Care are trademarks of DaimlerChrysler. HomeLink is a registered trademark of Johnson Controls, Inc. Infinity Acoustic 10 is a trademark of Infinity Systems, Inc. CATIA is a registered trademark of Dassault Systems.

Always use seat belts. Remember a backseat is the safest place for children.

CHRYSLER



ENGINEERED TO BE GREAT CARS