

HOW TO NAVIGATE

To Turn the Pages

Touch/Click the arrows on either side of the brochure

Table of Contents

Touch/Click the Table of Contents button in the top navigation bar of the screen to advance to specific areas of interest

Video Components

To play video embedded within the brochure a live internet connection is required



AMERICAN CULTURE + ART + DESIGN • 2015 CHRYSLER TOWN & COUNTRY

2015 CHRYSLER TOWN & COUNTRY



Where you live and where you love.
Where you work, drive and travel.

Places are just states of mind.
How you got there is part of the story.

OUR TOWN & COUNTRY - THE STORY OF US

For every road traveled, it's as if it was paved just for you. Because an idea or design is never as original as the route taken by original people like you. To see and perceive, feel and hope in only the way that you can and the way that you do. It is beauty in the eye of the beholder.

BEHOLD YOU: AN ORIGINAL

Design your life and we'll get you there.

What it takes to make great design from the inside out. It's not what your car says about you, it's what goes into your choice of one. It's how you build your home, family and the passions you pursue. You decide your life and style and your vehicle should never claim to speak on your behalf. At Chrysler, we know that when we do our best - when we make a vehicle that is strong and safe, versatile and innovative, responsive and reliable, beautiful and luxurious to the touch and to the eye - that it complements you.

And becomes part of your story.



LIMITED PLATINUM & LIMITED

P.4
New Limited Platinum Edition
Power Sunroof
Power Folding 3rd-row Seat
Auto High-Beam and
High Intensity Discharge (HID) Headlamps
Interior Design/Comfort & Convenience
Leather-trimmed Seating
Heated Front Seats and Steering Wheel
Towing Capacity



TOURING-L & S

P.8
Seating for Seven
S Badging, Black Chrome Grille, Body Accents
S Black Torino Leather-wrapped Seating
with Cloth Inserts
Black Leather-wrapped Steering Wheel
S Interior Finishing Touches
Super Console, Performance Suspension
Tailgate Seat



TOURING & LX

P.14
Base Model Standard Lineup Features
Leather-trimmed Seating
3.6L Pentastar® V6 Engine
Fuel Efficiency
Horsepower
Stow 'n Go® Seating and Storage
Stow N Place Roof Rack



TECH CONNECT

P.18
Driver Information Display (DID)
Premium Alpine® Sound System
Blu-ray™ DVD, HDMI, USB Ports
Uconnect® Touchscreen
Phone, Entertainment, Bluetooth®
Navigation, Voice Command!™
SiriusXM® Radio² and SiriusXM Travel Link³



SAFETY & SECURITY

P.20
Advanced Multistage Air Bags⁴ Side Air Bags⁴
Strategically Placed High-strength Steel
Blind Spot Monitoring⁵/Rear Cross-Path Detection⁶
ParkView® Rear Back-Up Camera⁶
ParkSense® Rear Park Assist⁶
Tire Pressure Monitoring
SafetyTec™ Package



WHEELS & ATTIRE

P.24
Buyer's Guide
Authentic Mopar® Accessories
Wheels/Fabrics
Interior Trim/Exterior Colors
Trim Levels
Standard and Optional Features

platinum



THE TOWN & COUNTRY LIMITED PLATINUM celebrates the ultimate progression in style and luxury with innovative versatility. Based on the already luxurious Limited model, Platinum represents the top of the line with unique adornments and comfort technology. Sumptuous Nappa Premium Leather is carried throughout the interior, wrapping the front bucket seats, as well as second- and third-row seats. The heated wood/leather-wrapped steering wheel takes Platinum's distinguished quality and ultra driver convenience to the foremost level along with memory features for heated front seats, mirrors and power adjustable pedals. A standard optimized nine-speaker Alpine® 506-watt sound system and Dual DVD/Blu-ray™ Entertainment System enhance the entire cabin experience. Giving this pinnacle model a standard comprehensive SafetyTec™ Package provides the technological driving and parking sensors, alerts and visual aid to automatically activate as needed. Platinum also includes a power sunroof, upgraded High Intensity Discharge (HID) headlamps, Limited badging, a dazzling chrome roof rack and 17-inch fully polished wheels that bring further Platinum distinction along with an everyday celebration of your lifestyle.



Limited Platinum shown in Brilliant Black Crystal Pearl.



limited

The Town & Country Limited incorporates its own level of sophistication, adding standard features to the Touring-L model, such as all three rows of seating with super-soft Alcantara® suede inserts in Black with Nappa Leather bolsters, interior Piano Black appliques and detailed armrest stitching. This upper classmate includes a class-exclusive⁷ heated steering wheel, navigation capability via the Uconnect® touchscreen, eight-way power driver and front-passenger seats, heated front- and second-row seats, and seating for seven with available luxury second-row seats. Standard features also include the premium Super Console for additional storage that includes device charging and USB outlets. With the SafetyTec™ advanced safety and technology features combined with a one-touch power folding third-row seat and power folding mirrors, Limited makes its standing known on 17-inch aluminum wheels.

TOW AND GO – BECAUSE SOME TOYS ARE TOO BIG TO STOW. With a towing capacity of up to 3,600 lb,* a Class II receiver hitch and a trailer tow wiring harness, as well as load leveling and height control, this available package gives even greater options to the already versatile lifestyle that Town & Country has to offer. Add in the standard Trailer Sway Control, part of Electronic Stability Control (ESC)⁸ which recognizes sway unique to trailering, automatically applying the brakes to individual wheels and/or reducing engine power to help eliminate trailer sway. You can rest at ease knowing this system will help keep you and the toys you are towing safely on course and under control.
*When properly equipped.



NO HIP-CHECKS REQUIRED. Touring-L drivers know that winning takes a back seat to getting your players to the arena on time with all of their equipment. With seating for seven and plenty of storage space for duffel bags and hockey sticks, Town & Country makes the goal. And the water-resistant leather-trimmed seats make the sweaty, thirst-quenching ride home skate by like a distant memory — until the next game.

TOWN & COUNTRY BEATS ITS OWN RECORD FOR AUTOMOTIVE LOYALTY. The Touring-L's popularity and long-standing, innovative versatility is the reason why the 2015 Chrysler Town & Country is the most trusted minivan ever.⁵ Including all of the versatile features on Touring, Touring-L adds perforated leather-trimmed seats for distinctive styling and ventilation along with a power front-row driver and passenger seat, window shades, an available class-exclusive⁷ heated steering wheel and an available class-exclusive⁷ Super Console for enhanced comfort and convenience. Touring-L also includes a standard SafetyTec™ Package with intuitive driver-aided advanced technologies like Blind Spot Monitoring⁵ and Rear Cross-Path Detection.⁶



DESTINATION: FIELD TRIP. Because the ride there and who comes with you is just as big of a deal as where you're going. And whether you're museum hopping or hip hopping, you're always ready to bring more along for the outing. Being the designated driver means all the standard safety rules apply, never getting lost, and having everyone's favorite music and movies at your fingertips. Never again will they ask how much longer, but they will ask when they can go again. With your Town & Country, it's just around the corner.



AN INSIDE ATTITUDE. A monotone Black interior, unique to the Town & Country S, starts with Black Torino leather-trimmed seats with Silver stitching and embroidered "S" logo, and Black Ballistic cloth seat inserts. Piano Gloss Black appliques are found on the instrument panel and the spokes of the Black leather-wrapped steering wheel, and the Chrysler wing design on the steering wheel matches the Black background of the exterior badging. Finishing interior touches include a Black headliner and upper consoles, Black center console and an "S" logo in the instrument panel cluster. A premium Super Console provides power outlets, cup holders, covered storage, and more to both front- and second-row passengers. A class-exclusive* dual Blu-ray™/DVD system with HDMI input and two USB ports for recharging is standard on S. This system allows backseat passengers to view standard DVDs and Blu-ray videos or to play a high-definition video game system on the screens. Wireless headphones allow backseat passengers to enjoy this state-of-the-art system without forcing front-seat passengers to hear the accompanying audio.



A SPORTING EXTERIOR. The Town & Country S brings a cool, modern design to the Touring model and is tailored for an active, style-minded lifestyle. The exterior enhancements, as well as premium standard equipment, make this edition a welcome member to the Chrysler family of S trims. The exterior features a Black chrome grille, Black-background front and rear Chrysler wing design badges, a Black rear fascia step pad, "S" model badging, blacked-out headlight bezels and 17-inch Hyper Black aluminum wheels. Premium, low-rolling resistance tires, low-drag brake calipers and rear bearings enhance fuel efficiency. The performance suspension on S adds a new level of handling dynamics to the driving experience, yet still provides a comfortable ride that's expected in a luxury minivan.

THE ABOVE-BOARD SURGE - SUP

FOR FAMILIES THAT SPORT TOGETHER. Whether you're considering trying your hand at stand-up paddle boarding or someone in your family has caught the wave, there's no doubt it's one of the fastest growing watersports for all levels and is becoming a popular outdoor activity. Invented in Hawaii as an alternative to traditional surfing, SUP has been gliding across the mainland throughout the past decade. Water- and fitness-loving SUPers are popping up along coasts, inland lakes and rivers, thanks to the versatility of this new sport. Offering unique horizon and under-the-surface views with minimal gear and beginning skill required, SUP makes the top of family outing lists. With an average board length of 10 ft, the Town & Country makes a great vehicle to safely transport them with ease.

ONLY PREMIUM MINIVAN WITH STANDARD POWER SLIDING DOORS? With the push of a button, in the cabin or on the key fob, the dual sliding doors effortlessly open. These power doors detect most obstacles in their path to automatically halt their motion and reverse.¹⁰

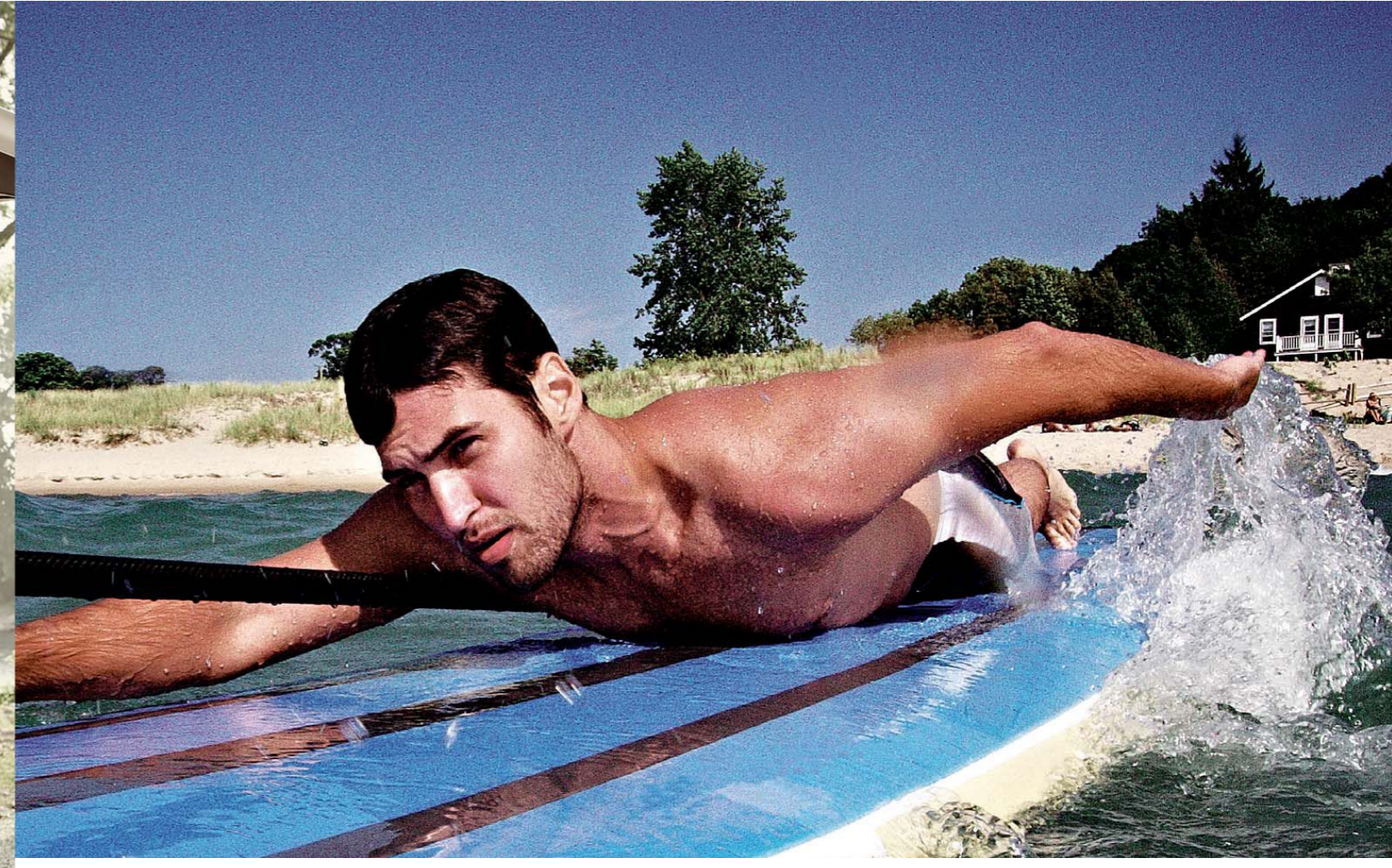

TAILGATE SEAT. The generous accommodations include an ingenious flip option for the third-row seat — folding it down over the bumper for a perfect tailgating bench. You'll gain space to stretch for putting on gear, watching the kids' game or simply enjoying the view from your personal shelter while you stay dry and comfortable.

[LEARN MORE CHRYSLER.COM](#)

POISED FOR PRACTICE
TRADITIONS ARE WHAT YOU INVENT

LEARN MORE
CHRYSLER.COM

25 HWY MPG*
FUEL ECONOMY

LX &
touring

THESE ARE THE DAYS. Special occasions can be found in the simple things when it's your day-in-the-life routine. That's why Town & Country provides a host of standard comfort, convenience, power and styling features that set the tone for the lineup. Starting with the LX base model, the packed standard-equipment features include leather-trimmed interior and seating, Uconnect® touchscreen radio with ParkView® Rear Back-Up Camera,⁶ three-zone HVAC, Stow N Place® Roof Rack, power sliding doors and liftgate, Stow 'n Go® seating and storage system, steering-wheel audio and cruise controls, sunscreen glass, power locks, power second-row windows, power third-row vents, six stereo speakers and 17-inch aluminum wheels. The Touring model then adds a single-DVD player, automatic temperature control, Electronic Vehicle Information Center (EVIC), fog lamps and automatic headlamps, power eight-way driver's seat and the added luster of chrome bodyside molding for a dressed-up attitude.

CONFIDENCE BOOSTER. Since getting everyone there confidently is the only option, you'll know why it matters to have a vehicle this powerful. Powered by the standard 3.6L Pentastar® V6 engine with Variable Valve Timing (VVT), this award-winning engine boasts best-in-class⁷ 283 horsepower and 260 lb-ft of torque, yet efficiently provides up to 25 highway mpg,* combining an exceptional blend of high torque, fuel efficiency, low emissions and quiet operation. The Chrysler Town & Country also features a class-exclusive Fuel Economizer feature that alters transmission shift patterns to help improve fuel efficiency with the touch of a button.

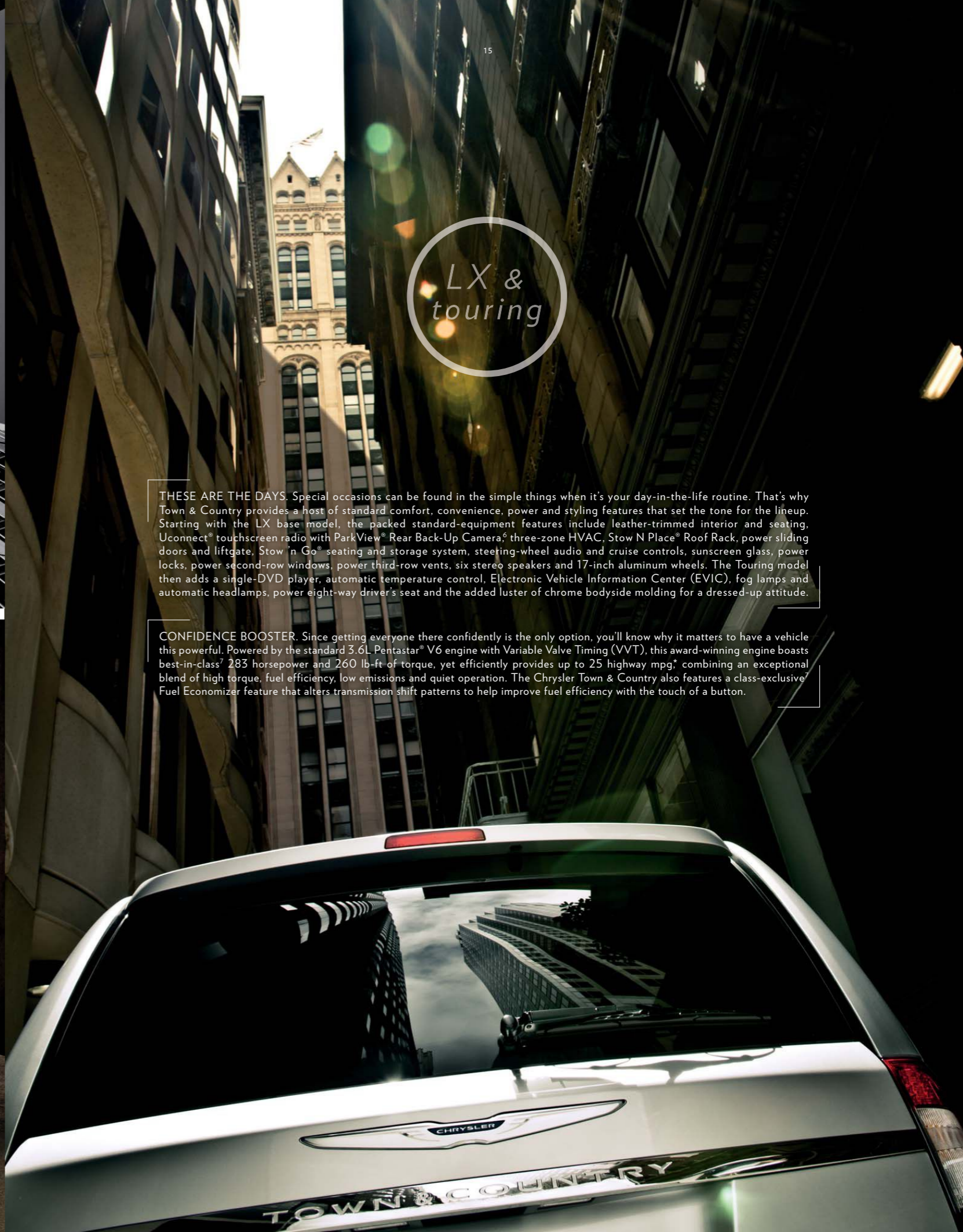

*2014 EPA estimated 17 city/25 hwy mpg with 3.6L engine and 6-speed automatic transmission.

ON-THE-FLY READY. Just because the schedule is booked doesn't mean you're not looking for an opening. And when you see it, you're ready to grab the gear and hit some open spaces. Canceled appointments are the new free time and everyone needs a little more of that. With your Town & Country, you're always ready for the openings. Enjoy the time with your favorite people and let them be them. Don't forget to capture and share your original moments at ChryslerOwners.com



INVENTING VERSATILITY
flipcity

THE MOST INNOVATIVE SEATING AND STORAGE IN ITS CLASS? Luxury need not come at the expense of practicality with standard leather-trimmed seats and the Stow 'n Go® seating and storage system from the LX model on up. The fold-and-stow second- and third-row seats fold individually into floor bins, allowing you to go from seven seats to two, or any combination in between. With all seats stowed, the Town & Country yields a flat cargo floor and 144.2 cubic feet of storage for easy loading without ever having to remove a seat. When the seats are in their upright positions, in-floor bins store a multitude of items, from laptops, purses and toys to backpacks and sporting equipment. The available class-exclusive® Stow N Place® Roof Rack System can carry up to 150 pounds of cargo while the convenience of folding crossbars that attach to the side rails when not in use improves aerodynamics.

ONE MOTION. The simple fold-and-stow system allows the head restraint to fold down automatically for easier operation and reveals what makes Town & Country legendary: Stow 'n Go® seating with in-floor storage bins and fold-in-floor second- and third-row seats. When the seats are in their upright positions, in-floor bins are available to accommodate carry-ons.

AVAILABLE THIRD-ROW POWER SEATS. With the touch of a button, the available one-touch power folding third-row 60/40 split-bench seat folds directly into the floor. This feature also includes obstacle detection¹⁰ to automatically pause if something is detected within the seat's path of motion.





the sweet sound of a life well-shared

mobiletainment

THE BEST MADE EVEN BETTER WITH BLU-RAY.™ Let this premium level of entertainment features keep your passengers occupied with the available Dual DVD/Blu-ray™ Entertainment System with class-exclusive? Blu-ray Disc™ player. With an available single-DVD system, two available nine-inch VGA high-resolution screens that flip down from the overhead console, two USB ports, HDMI connectivity and game-console inputs, the kids don't have to settle on just one thing to watch.

The video system can be operated from either the rear-seat entertainment unit, the wireless remote or the radio head unit. The self-contained entertainment system is located in the overhead rail, which also contains storage for the wireless headphones and remote. LED Blue Sapphire halo lighting glows from the overhead rail, providing a relaxing environment for viewing. SiriusXM Satellite Radio² is also standard on all models. The game shown — Disney®/Pixar's Brave: The Video Game — is available now for Xbox® 360. © 2014 Disney/Pixar



LEARN MORE CHRYSLER.COM



UCONNECT® TOUCHSCREEN FOR MUSIC, NAVIGATION AND COMMUNICATION.

ENTERTAINMENT. Manage all your media with multiple ways to access audio, including Bluetooth® Streaming Audio, iPod® control with Voice Command¹, DVD player, auxiliary input jack, SD card slot and compatible multimedia devices with SiriusXM® Satellite Radio² (one year of service included).

PHONE. Uconnect Phone is the in-vehicle, voice-activated communication system that allows you to pair up to seven Bluetooth compatible phones and then talk virtually hands-free. This system is also clever enough to synchronize with your phone's contacts¹¹ — up to 1,000 entries.

VOICE COMMAND¹ It helps simplify driving by letting you keep your eyes on the road and your hands on the wheel. Use your voice to select AM/FM radio stations and SiriusXM Satellite Radio² channels, and make calls.

WEB.¹¹ Put the power of high-speed Internet in your vehicle with Mopar® Web,¹² making your vehicle a mobile hotspot. Passengers can use multiple devices at the same time. There's no need for cell cards or software with this Authentic Chrysler Accessory by Mopar. It's all wireless. Subscription required. Sold separately.

NAVIGATION. Provides turn-by-turn voice guidance and visual display. It features the Garmin® intuitive user interface, bringing the Garmin handheld experience to a factory in-dash radio.

SIRIUSXM TRAVEL LINK.³ Brings national weather forecasts, fuel prices for local gas stations, in-game and final sports scores, weekly sports schedules, local movie theater listings and local ski conditions right to your vehicle. Your first five years of SiriusXM Travel Link is included.

SIRIUSXM ALL ACCESS PACKAGE.² Enjoy over 150 channels of the best programming for all the places life takes you. In your vehicle — you'll get every channel available on your radio, including all the premium programming. On the go — with a SiriusXM Internet Radio² subscription included with the All Access² trial, you'll get SiriusXM² on your computer, smartphone or tablet. Go to siriusxm.com/getallaccess for more information.

GO TO DRIVEUCONNECT.COM TO FIND OUT MORE.

LEARN MORE DRIVEUCONNECT.COM





SECURING YOUR MOST VALUABLE ASSETS. All Town & Country vehicles are equipped with the child restraint anchorage system called LATCH (Lower Anchors and Tethers for Children). The system has three vehicle anchor points for installing LATCH-equipped child seats without using the vehicle's seat belts.

POWER LIFTGATE WITH OBSTACLE DETECTION!⁹ Like the sliding doors, the power liftgate detects most obstacles in its path and will automatically stop and reverse.

CHILD PROTECTION REAR DOOR LOCKS. A small lever on the front edge of the sliding door disables the rear doors' inside release handles.

PROTECTING YOU AND YOUR FAMILY IS OUR STRONGEST INSTINCT.

BULLYING AFFECTS US ALL. IT'S UP TO ALL OF US TO PREVENT IT.



CHRYSLER AND THE RFK CENTER.
The Chrysler brand has a proud tradition of helping to keep families safe and secure. And when it comes to keeping them safe from bullying, we've taken on a prevention initiative. We've partnered with Mrs. Robert F. Kennedy and Kerry Kennedy of the Robert F. Kennedy Center for Justice and Human Rights to raise awareness about this problem. Together we can help stop bullying before it starts.

PROJECT SEATBELT.
For the majority of U.S. drivers, fastening a seat belt when they get into a car is an automatic behavior. Although seat belts don't protect drivers or passengers from all injuries or harm, buckling a seat belt has been shown to significantly reduce the risk.

Just as we buckle our seat belts to keep ourselves and others safe, we can take measures to prevent bullying and keep all young people safe. When children and teenagers feel safe and supported in their homes, schools and communities, they are significantly less likely to experience bullying.

Too often, we think about bullying only after it has happened. Parents may not talk to their children about bullying until they are already affected. Schools often institute an "anti-bullying" policy, but may not take the critical steps needed to make that policy work. Just like a seat belt, a policy cannot work if it just hangs there – it needs to be engaged.

The mission of RFK Project SEATBELT is to create the conditions at home, at school and in the community so that treating EVERYONE with respect becomes the norm – in other words, universal respect becomes as automatic as fastening a seat belt.

 Learn more at: bullying.rfkcenter.org/what-is-seatbelt

IT'S THE LEVEL OF SAFETY AND SECURITY THAT YOU'LL CALL PEACE OF MIND.

AVAILABLE SAFETYTEC™ PACKAGE. Additional technologically advanced offerings are bundled among the 53 standard and available safety and security features that help to protect what matters most. The SafetyTec Package includes rain-sensing windshield wipers, Auto High-Beam Headlamp Control, Tire Pressure Monitoring Display, ParkSense® Rear Park Assist⁶ and Blind Spot Monitoring⁵ with Rear Cross-Path Detection⁶. These active technological features put Town & Country in a class by itself.

ADVANCED MULTISTAGE FRONT AIR BAGS⁴ This feature regulates the amount of force necessary for the front occupants by impact severity, including low-risk deployment.

FRONT SEAT-MOUNTED SIDE AIR BAGS⁴ Additional air bags are integrated into the front seats to offer pelvic and thorax protection. The air bags deploy consistently with driver and front-passenger seat positions.

SUPPLEMENTAL SIDE-CURTAIN AIR BAGS⁴ These air bags extend protection to all outboard front- and rear-seat passengers, including third-row outboard passengers. Upon side impact, the system deploys the specific side air bag and curtain required for occupant protection.

TIRE PRESSURE MONITORING SYSTEM. Individual tire pressure amounts are displayed in the instrument cluster and alert the driver to tires with high or low pressure.

CONSTANT-FORCE RETRACTORS. Seat belt retractors sense vehicle impact and immediately apply pressure to the seat belt to properly position the occupant before the full load of impact is imparted. It then reduces the seat belt load in order to moderate forces during the impact event.

DRIVER'S INFLATABLE KNEE BLOCKER⁴ This separate air bag located in the lower instrument panel is designed to help position the driver properly for the front air bag.

ACTIVE FRONT-ROW HEAD RESTRAINTS¹³ In the event of a rear-end collision, these restraints automatically move forward and upward to decrease the space between the head restraint and the occupant's head.



STRATEGICALLY PLACED HIGH-STRENGTH STEEL. Town & Country architecture includes dual-phase, high-strength and hot-stamped steel, resulting in a strong safety cage that contributes to overall vehicle-impact performance.

CRUMPLE ZONES. In the event of an impact, specifically designed front and rear crush zones absorb energy and redirect it away from passengers, helping to reduce the risk of injury.

SECURITY CLEARANCE.

ENHANCED ACCIDENT RESPONSE SYSTEM (EARS). All Town & Country vehicles are equipped with EARS. This system makes it easier for emergency personnel to see and reach occupants in the event of an accident by turning on interior lighting, flashing hazard lamps and unlocking doors after air bag⁴ deployment. EARS also shuts off the flow of fuel to the engine.

POWER ADJUSTABLE PEDALS. Available adjustable brake and accelerator pedals allow you to customize their position, enabling you to maintain a comfortable distance from the steering wheel. The memory function on Limited Platinum customizes each fob's position setting.

DOOR ALERT. This selectable feature automatically flashes signal lights, indicating which sliding door is open.

ONLY PREMIUM MINIVAN WITH STANDARD POWER SLIDING DOORS.⁸ With the push of a button, in the cabin or on the key fob, the dual sliding doors effortlessly open. These power doors detect most obstacles¹⁰ in their path to automatically halt their motion and reverse.

REMOTE KEYLESS ENTRY. The power sliding doors and power liftgate allow you to slide open rear doors and open the liftgate, all with the touch of just a couple of buttons on the key fob, overhead console or inside the cabin.

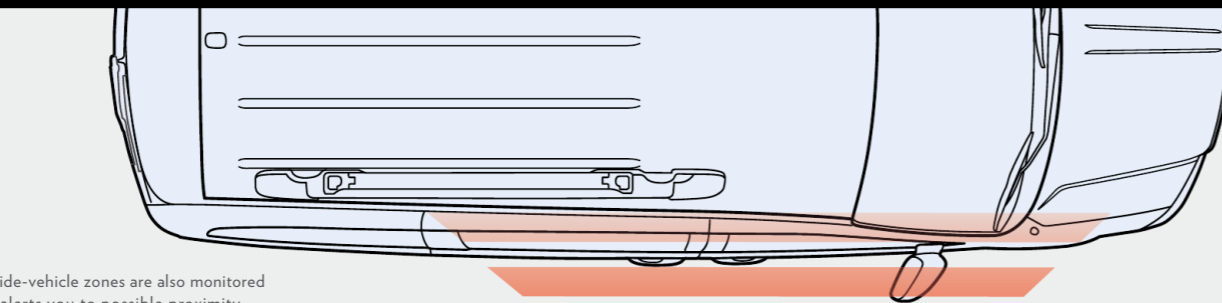

BLIND SPOT MONITORING (BSM)⁵ Difficult-to-view side-vehicle zones are also monitored by the radar technology of this available feature which alerts you to possible proximity danger when driving. While traveling in forward gears, an illuminated icon appears in the driver's sideview mirror and an audible warning sounds (if activated) when another vehicle is approaching alongside. BSM is included as part of the available SafetyTec™ Package and includes Rear Cross-Path Detection.⁶

REAR CROSS-PATH DETECTION⁶ Included as part of the available SafetyTec™ Package, Rear Cross-Path Detection⁶ alerts the driver to most approaching low-speed vehicles when backing out of parking spots.



PARKSENSE® REAR PARK ASSIST⁶ This available feature uses radar technology to detect most obstacles¹⁰ behind the vehicle and gives the driver both visual and audible alerts about those obstacles.

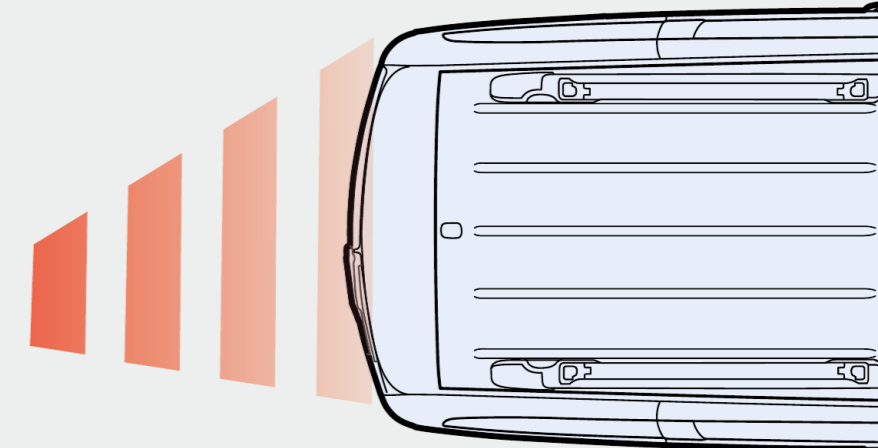
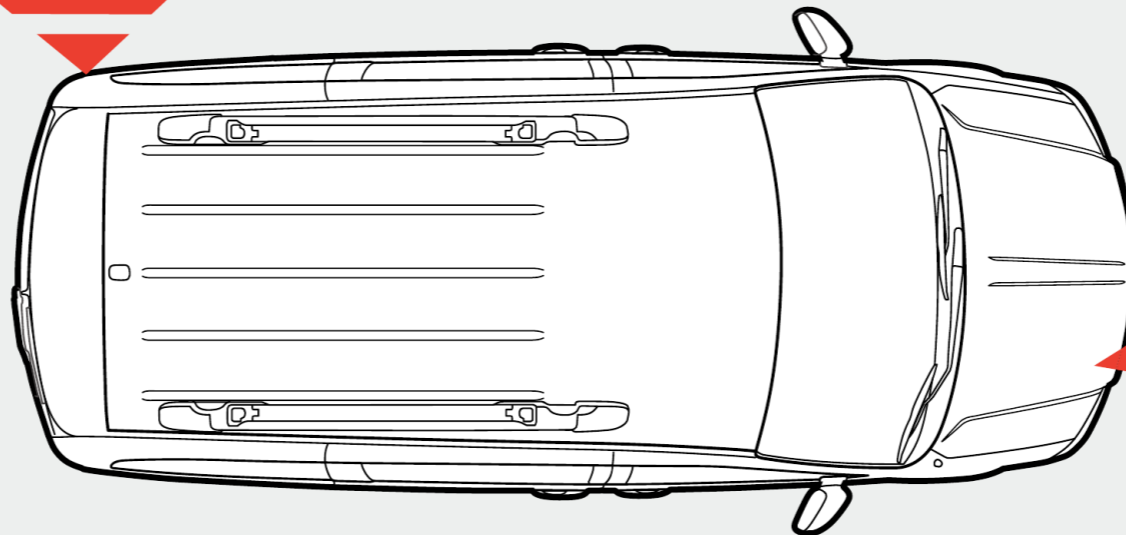
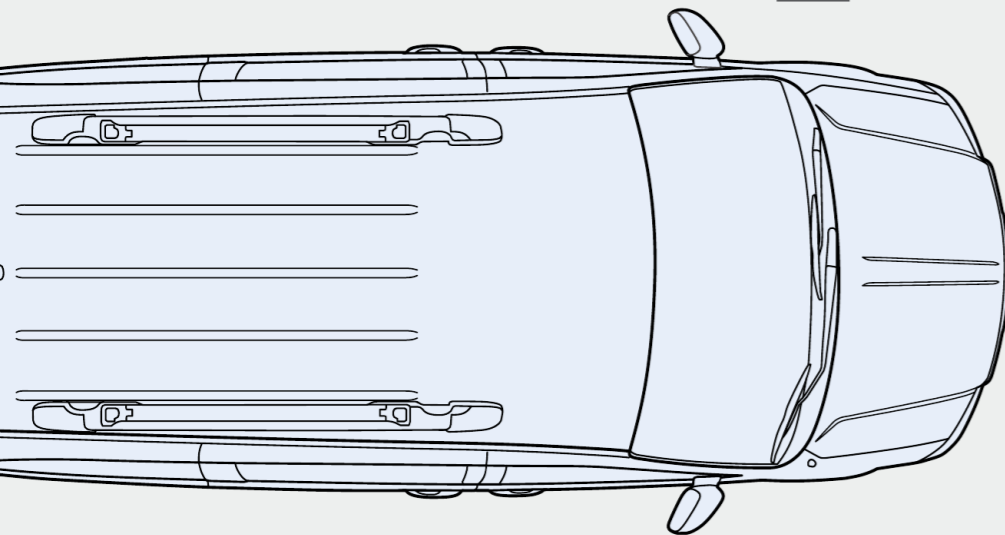



BUILD & PRICE



FIND A DEALER



LEARN MORE
CHRYSLER.COM

WHEELS & ATTIRE

WHEELS & ATTIRE

SELECT FEATURES	LX	TOURING	S MODEL	TOURING-L	LIMITED	LIMITED PLATINUM
MECHANICAL FEATURES						
ALTERNATOR – 160-AMP	*	*	*	*	*	*
BATTERY – 730-AMP, MAINTENANCE-FREE	*	*	*	*	*	*
BRAKES – 4-WHEEL ANTILOCK WITH VENTED FRONT AND SOLID REAR DISCS	*	*	*	*	*	*
ENGINE BLOCK HEATER	O	O	O	O	O	O
ENGINE OIL COOLER	*	*	*	*	*	*
ENGINES/TRANSAXLE – 3.6L PENTASTAR® V6 VVT FLEX FUEL WITH 6-SPEED AUTOMATIC	*	*	*	*	*	*
DEFROSTER – REAR WINDOW	*	*	*	*	*	*
FUEL OPTIMIZER SWITCH	*	*	*	*	*	*
FUEL TANK – 20-GALLON WITH TETHERED CAP	*	*	*	*	*	*
HEAVY-DUTY ENGINE COOLING – INCLUDES ENGINE OIL COOLER, HEAVY-DUTY TRANSMISSION COOLER AND HEAVY-DUTY RADIATOR	*	*	*	*	*	*
HORN – DUAL-NOTE, ELECTRIC	*	*	*	*	*	*
SPEED CONTROL – ELECTRONIC WITH STEERING WHEEL-MOUNTED CONTROLS	*	*	*	*	*	*
STEERING – POWER, RACK AND PINION	*	*	*	*	*	*
SUSPENSION – TOURING-TUNED, FRONT INDEPENDENT MACPHERSON STRUTS WITH REAR TWIST-BEAM AXLE WITH COIL SPRINGS	*	*	*	*	*	*
– PERFORMANCE SUSPENSION			*			
– LOAD-LEVELING AND HEIGHT-CONTROL (INCLUDED IN TRAILER TOW GROUP, PREMIUM GROUP OR MOBILITY PREP GROUP)	P	P	P	P	P	P
TIP START – QUIET START, PREVENTS DOUBLE STARTS	*	*	*	*	*	*
EXTERIOR FEATURES						
DOOR HANDLES – BODY-COLOR	*	*	*	*	*	*
– BRIGHT					*	*
DOOR LOCKS – POWER	*	*	*	*	*	*
DOORS – PASSENGER-SIDE POWER SLIDING	*	*	*	*	*	*
– DRIVER-SIDE POWER SLIDING	*	*	*	*	*	*
FASCIA – BODY-COLOR FRONT AND REAR, WITH REAR SCUFF PAD	*	*	*	*	*	*
FOG LAMPS – PROJECTOR		*	*	*	*	*
GLASS – SUNSCREEN	*	*	*	*	*	*
GRILLE – BRIGHT	*	*	*	*	*	*
– BLACK CHROME			*			
HEADLAMP BEZELS – BLACK			*			
HEADLAMPS – QUAD-HALOGEN WITH HEADLAMPS-OFF TIME DELAY	*	*	*	*	*	*
– DUAL HIGH INTENSITY DISCHARGE (HID) WITH HEADLAMPS-OFF TIME DELAY						*
– AUTOMATIC		*	*	*	*	*
– AUTO HIGH-BEAM HEADLAMP CONTROL (INCLUDED IN SAFETYTEC™ PACKAGE)		P	P	*	*	*
LIFTGATE – POWER	*	*	*	*	*	*
MIRRORS – BODY-COLOR, FOLDING, POWER, HEATED	*	*	*	*	*	*
– CHROME, POWER, HEATED, WITH SUPPLEMENTAL SIGNALS, EXTERIOR DRIVER'S-SIDE AUTO-DIMMING				*		
– CHROME, POWER FOLDING, HEATED, WITH SUPPLEMENTAL SIGNALS AND EXTERIOR DRIVER'S-SIDE AUTO-DIMMING					*	
– CHROME, POWER FOLDING, HEATED, WITH SUPPLEMENTAL SIGNALS AND EXTERIOR DRIVER'S-SIDE AUTO-DIMMING WITH MEMORY FEATURE						*
MOLDING – BODY-COLOR BODYSIDE	*	*	*	*	*	*
– BRIGHT BODYSIDE		*	*	*	*	*
– BRIGHT BELT	*	*	*	*	*	*
ROOF RACK – STOW N PLACE® WITH BLACK SIDE RAILS	*	*	*	*	*	*
– STOW N PLACE WITH BRIGHT SIDE RAILS WITH BLACK END CAPS					*	*
SILL APPLIQUÉ – BODY-COLOR	*	*	*	*	*	*
SUNROOF – POWER, INCLUDES DUAL REAR MINI OVERHEAD CONSOLES WITH TWO BINS (REPLACES OVERHEAD CONSOLE AND APPLIQUÉ SUNGLASSES BIN)		O		O	O	*
TIRES – P225/65R17 BSW ALL-SEASON	*	*	*	*	*	*
– P225/65R17 BSW ALL-SEASON TOURING				*	*	*

* = Included. O = Optional. P = Available within Package noted.

SELECT FEATURES	LX	TOURING	S MODEL	TOURING-L	LIMITED	LIMITED PLATINUM
EXTERIOR FEATURES (CONTINUED)						
TIRE INFLATOR KIT	*	*	*	*	*	*
– COMPACT SPARE TIRE	O	O	O	O	O	*
WHEELS – 17-INCH ALUMINUM	*	*	*	*	*	*
– 17-INCH HYPER BLACK ALUMINUM			*			
– 17-INCH PAINTED ALUMINUM				*		
– 17-INCH POLISHED ALUMINUM					*	*
– 17-INCH SATIN SILVER ALUMINUM*						*
WINDOWS – POWER FRONT ONE-TOUCH UP/DOWN ON THE DRIVER'S SIDE AND ONE-TOUCH DOWN ON THE PASSENGER SIDE	*	*	*	*	*	*
– POWER 2ND-ROW	*	*	*	*	*	*
– POWER REAR-QUARTER VENTS	*	*	*	*	*	*
WINDSHIELD WIPERS – VARIABLE/INTERMITTENT	*	*	*	*	*	*
– RAIN-SENSING (INCLUDED WITH SAFETYTEC™ PACKAGE)		P	P	*	*	*
– REAR WINDOW WIPER/WASHER	*	*	*	*	*	*
INTERIOR FEATURES						
AIR CONDITIONING – THREE-ZONE TEMPERATURE CONTROL	*	*	*	*	*	*
– THREE-ZONE AUTOMATIC TEMPERATURE CONTROL WITH PARTICULATE AIR FILTER		*	*	*	*	*
ASSIST HANDLES – FRONT-PASSENGER, MOUNTED ON A-PILLAR; 2ND-ROW, MOUNTED IN HEADLINER AND ON B-PILLAR	*	*	*	*	*	*
CARPETS – FLOOR AND CARGO AREA	*	*	*	*	*	*
CLOCK – ANALOG	*	*	*	*	*	*
CONSOLE – OVERHEAD WITH INTERIOR OBSERVATION MIRROR, SUNGLASSES BIN, LED LAMPS AND SWITCHES FOR POWER DOORS AND LIFTGATE	*	*	*	*	*	*
– SINGLE REAR OVERHEAD CONSOLE SYSTEM INCLUDES FOUR STORAGE BINS, 2ND- AND 3RD-ROW SWIVEL LED LAMPS AND HALO LIGHT RING (REPLACED BY DUAL MINI OVERHEAD CONSOLE IF SUNROOF IS ORDERED; IF ORDERED, THE VIDEO SCREENS WILL DELETE THE OVERHEAD STORAGE BINS)	*	*	*	*	*	*
ELECTRONIC VEHICLE INFORMATION CENTER (EVIC) – COLOR DISPLAY IN INSTRUMENT PANEL WITH CONTROLS ON THE STEERING WHEEL		*	*	*	*	*
FLOOR MATS – EASY-CLEAN	O	O	O	O	O	O
FLOOR SILENCER – REAR	*	*	*	*	*	*
GARAGE DOOR OPENER – PROGRAMMABLE, THREE-FUNCTION WITH REMOTE CONTROLS FOR GARAGE DOOR OPENERS, INTERIOR/EXTERIOR HOME LIGHTING OR FOR SECURITY DEVICES	*	*	*	*	*	*
GLOVE BOX – DUAL	*	*	*	*	*	*
GROCERY BAG HOOKS – REAR, 3RD-ROW SEATBACK	*	*	*	*	*	*
INTERIOR ACCENTS – CHROME	*	*	*	*	*	*
LIGHTING – OVERHEAD AMBIENT SURROUND LIGHTING	*	*	*	*	*	*
– REAR SWIVELING READING/COURTESY	*	*	*	*	*	*
– LIFTGATE, SINGLE FLOODLAMP	*	*	*	*	*	*
– LED, LOCATED IN OVERHEAD THAT ILLUMINATES THE FRONT CENTER CUP HOLDER AND CONSOLE	*	*	*	*	*	*
– ILLUMINATED FRONT-DOOR STORAGE	*	*	*	*	*	*
– DOOR COURTESY LAMPS	*	*	*	*	*	*
MIRRORS – REARVIEW, AUTO-DIMMING	*	*	*	*	*	*
– ILLUMINATED VISOR VANITY	*	*	*	*	*	*
POWER OUTLETS – 12-VOLT DC LOCATED IN INSTRUMENT PANEL AND REAR QUARTER-TRIM PANEL	*	*	*	*	*	*
– AUXILIARY, 12-VOLT IN INSTRUMENT PANEL	*	*	*	*	*	*
– AUXILIARY, 115-VOLT INVERTER WITH AUXILIARY OUTLETS IN FRONT OF DRIVER-SIDE QUARTER-TRIM PANEL	*	*	*	*	*	*
SHADES – 2ND- AND 3RD-ROW RETRACTABLE WINDOW		O	O	*	*	*
SHIFT KNOB – LEATHER-WRAPPED	*	*	*	*	*	*
STEERING COLUMN – TILT/TELESCOPING, MANUAL	*	*	*	*	*	*

* = Included. O = Optional. P = Available within Package noted. *Late availability.



BUILD & PRICE



FIND A DEALER



LEARN MORE
CHRYSLER.COM

WHEELS & ATTIRES

WHEELS & ATTIRES

SELECT FEATURES

	LX	TOURING	S MODEL	TOURING-L	LIMITED	LIMITED PLATINUM
INTERIOR FEATURES (CONTINUED)						
STEERING WHEEL – LEATHER-WRAPPED	•	•		•	•	
– LEATHER-WRAPPED WITH ACCENTS			•			
– WOOD/LEATHER-WRAPPED						•
– STEERING WHEEL-MOUNTED AUDIO CONTROLS	•	•	•	•	•	•
– HEATED (INCLUDED WITH DRIVER CONVENIENCE GROUP)		P	P	P	•	•
– BLACK GLOSS FINISH INSTRUMENT PANEL			•		•	
STORAGE – OPEN BIN IN LOWER INSTRUMENT PANEL, WITH LEFT REAR QUARTER-TRIM BIN	•	•		•	•	
– BLACK INSTRUMENT PANEL			•			
– CONSOLE, PREMIUM, REMOVABLE, SLIDING FLOOR CONSOLE WITH CUP HOLDERS AND POWER OUTLET; CAN BE ADJUSTED FOR 2ND-ROW PASSENGER USE		•		•		○
– SUPER CONSOLE – INTEGRATED CENTER CONSOLE WITH COVERED STORAGE BINS, CUP HOLDERS FOR 1ST AND 2ND ROWS, LARGE STORAGE DRAWER AND TWO POWER OUTLETS			•	○	•	•
SEATING						
FABRICS – PREMIUM CLOTH		○				
– LEATHER-TRIMMED 1ST- AND 2ND-ROW	•	•				
– PERFORATED LEATHER-TRIMMED 1ST- AND 2ND-ROW				•		
– BLACK TORINO LEATHER-TRIMMED 1ST- AND 2ND-ROW WITH EMBROIDERED "S" LOGO IN SEATBACKS AND BLACK BALLISTIC CLOTH INSERTS			•			
– NAPPA LEATHER-TRIMMED WITH ALCANTARA® SUEDE INSERTS, 1ST- AND 2ND-ROW BUCKET SEATS					•	
– LUXURY NAPPA LEATHER-TRIMMED 1ST- AND 2ND-ROW WITH SUEDE MICROFIBER ACCENTS						•
– FRONT, 8-WAY POWER DRIVER'S SEAT WITH TWO-WAY POWER LUMBAR ADJUSTER	○	•	•			
– EIGHT-WAY POWER DRIVER'S SEAT AND EIGHT-WAY FRONT-PASSENGER SEAT, WITH TWO-WAY POWER LUMBAR ADJUSTER FOR DRIVER'S SEAT (LIMITED PLATINUM INCLUDES DRIVER'S-SEAT MEMORY FEATURE)				•	•	•
– HEATED FRONT (INCLUDED IN DRIVER CONVENIENCE GROUP)		P	P	P	•	•
– HEATED 2ND-ROW (INCLUDED IN DRIVER CONVENIENCE GROUP)			P	P	•	•
REAR – STOW 'N GO® SEATING AND STORAGE SYSTEM WITH INTERMEDIATE BUCKET SEATS WITH FOLD-IN-FLOOR AND REAR 60/40 SPLIT-FOLDING BENCH WITH FOLD-IN-FLOOR AND TAILGATE POSITION FEATURES	•	•	•	•	•	•
– INTERMEDIATE LUXURY BUCKETS WITH REAR FOLD-IN-FLOOR SEATING				○		○
– POWER ONE-TOUCH-FOLDING 3RD-ROW WITH POWER RECLINE (INCLUDED IN PREMIUM GROUP)				P	•	•

EXCLUSIVE STOW 'N GO. Fold-and-stow system allows the head restraint¹³ to fold down automatically for simple one-motion operation.



AVAILABLE THIRD-ROW POWER SEATS. One-touch power-folding third-row 60/40 split-bench seat folds directly into the floor.



• = Included. ○ = Optional. P = Available within Package noted.

SELECT FEATURES

	LX	TOURING	S MODEL	TOURING-L	LIMITED	LIMITED PLATINUM
UCONNECT®						
UCONNECT 430 – CD/DVD/MP3/HDD RADIO WITH 6.5-INCH TOUCHSCREEN, 28GB HARD DRIVE (APPROXIMATELY 6,700-SONG CAPACITY), GRACENOTE MUSIC ID® AND AUXILIARY JACK, SIRIUSXM® SATELLITE RADIO ² AND PARKVIEW® REAR BACK-UP CAMERA ⁶	•	•	•	•		
UCONNECT 430N – CD/DVD/MP3/HDD RADIO WITH 6.5-INCH TOUCHSCREEN, GPS NAVIGATION, 28GB HARD DRIVE (APPROXIMATELY 4,250-SONG CAPACITY), SIRIUSXM SATELLITE RADIO ² , SIRIUSXM TRAVEL LINK ³ , GRACENOTE MUSIC ID, IPOD® CONTROL, AUXILIARY JACK, BLUETOOTH® STREAMING AUDIO AND PARKVIEW REAR BACK-UP CAMERA ⁶		○	○	○	•	•
SIRIUSXM SATELLITE RADIO ² – INCLUDES ONE-YEAR SUBSCRIPTION	•	•	•	•	•	•
SPEAKERS – SIX	•	•	•	•	•	
– NINE AMPLIFIED WITH SUBWOOFER; INCLUDES 506-WATT AMPLIFIER						•
VIDEO SCREEN – 2ND-ROW 9-INCH QVGA SCREEN WITH DVD PLAYER		•		•	•	
– 2ND- AND 3RD-ROW 9-INCH QVGA SCREENS WITH DVD PLAYER AND BLU-RAY™ PLAYER			•	○	○	•
SAFETY & SECURITY FEATURES						
ACTIVE HEAD RESTRAINTS ¹⁵ – FRONT-ROW SEATS	•	•	•	•	•	•
AIR BAGS ⁴ – ADVANCED MULTISTAGE DRIVER AND FRONT-PASSENGER, INCLUDES LOW-RISK DEPLOYMENT	•	•	•	•	•	•
– SIDE-CURTAIN ⁵ FOR OUTBOARD OCCUPANTS IN ALL THREE ROWS	•	•	•	•	•	•
– FRONT SEAT-MOUNTED SIDE ⁴	•	•	•	•	•	•
– DRIVER'S INFLATABLE KNEE BLOCKER ⁴	•	•	•	•	•	•
BLIND SPOT MONITORING SYSTEM ⁵ – INCLUDED IN SAFETYTEC™ PACKAGE		P	P	•	•	•
CHILD SEAT ANCHOR SYSTEM (LATCH) – MOUNTS FOR TWO CHILD SEATS IN THE 2ND ROW HELP EASE THE INSTALLATION OF COMPATIBLE AFTERMARKET CHILD SEATS	•	•	•	•	•	•
ELECTRONIC STABILITY CONTROL ⁸ – INCLUDES BRAKE ASSIST AND ALL-SPEED TRACTION CONTROL	•	•	•	•	•	•
PARKSENSE® REAR PARK ASSIST SYSTEM ⁶ – INCLUDED IN SAFETYTEC PACKAGE		P	P	•	•	•
PARKVIEW REAR BACK-UP CAMERA ⁶	•	•	•	•	•	•
PEDALS – POWER ADJUSTABLE WITH MEMORY FEATURE						•
REAR CROSS-PATH DETECTION ⁶ – INCLUDED IN SAFETYTEC PACKAGE		P	P	•	•	•
REMOTE KEYLESS/ILLUMINATED ENTRY SYSTEM – INCLUDES TWO TRANSMITTERS, SENTRY KEY® ANTI-THEFT ENGINE IMMOBILIZER AND HEADLAMPS-OFF TIME DELAY	•	•	•	•	•	•
SLIDING DOOR ALERT SYSTEM ¹⁰ – HAZARD LAMPS FLASH WHEN SLIDING DOOR IS IN OPERATION, SIGNALING OTHER DRIVERS THAT PASSENGERS COULD BE ENTERING/EXITING THE VEHICLE	•	•	•	•	•	•
TIRE PRESSURE MONITORING WARNING LAMP	•	•	•			
TIRE PRESSURE MONITORING DISPLAY SYSTEM – DISPLAYS TIRE PRESSURE FOR EACH INDIVIDUAL TIRE (INCLUDED WITH SAFETYTEC PACKAGE)		P	P	•	•	•
UCONNECT VOICE COMMAND ¹ – REQUIRES BLUETOOTH COMPATIBLE PHONE; INCLUDES REMOTE USB PORT	•	•	•	•	•	•
PACKAGES/EQUIPMENT GROUPS						
DRIVER CONVENIENCE GROUP – INCLUDES HEATED STEERING WHEEL, HEATED FRONT SEATS		○	○	○		
DUAL DVD/BLU-RAY ENTERTAINMENT GROUP – INCLUDES 2ND- AND 3RD-ROW QVGA 9-INCH SCREENS, BLU-RAY DVD PLAYER, HIGH-DEFINITION MULTIMEDIA INTERFACE AND USB CHARGING PORTS, WIRELESS HEADPHONES, VIDEO REMOTE CONTROL			•	○	○	•
PREMIUM GROUP – INCLUDES POWER FOLDING 3RD-ROW SEAT, CHROME POWER FOLDING HEATED EXTERIOR MIRRORS WITH TURN SIGNAL INDICATORS AND AUTO-DIMMING FEATURE FOR DRIVER'S MIRROR				○	•	•
SAFETYTEC PACKAGE – INCLUDES RAIN-SENSING WINDSHIELD WIPERS, AUTO HIGH-BEAM HEADLAMP CONTROL, TIRE PRESSURE MONITORING DISPLAY, PARKSENSE REAR PARK ASSIST SYSTEM ⁶ , BLIND SPOT MONITORING ⁵ AND REAR CROSS-PATH DETECTION ⁶		○	○	•	•	•
SINGLE-DVD ENTERTAINMENT GROUP – INCLUDES 2ND-ROW 9-INCH QVGA SCREEN, HIGH-DEFINITION MULTIMEDIA INTERFACE AND USB CHARGING PORTS, WIRELESS HEADPHONES, VIDEO REMOTE CONTROL		•		•	•	
TRAILER TOW GROUP – INCLUDES CLASS II RECEIVER HITCH AND LOAD-LEVELING AND HEIGHT-CONTROL SUSPENSION		○	○	○	○	○
MOPAR® WEB ¹² – AN AUTHENTIC ACCESSORY FROM MOPAR		○	○	○	○	○

• = Included. ○ = Optional. P = Available within Package noted.



Choose Authentic Chrysler Accessories by Mopar® for quality parts and accessories made to custom-fit your Chrysler Town & Country. Mile after mile, you'll keep going strong with our expert technicians, genuine parts, Mopar Vehicle Protection® plans, Express Lane Service and online Mopar Owner Connect® Web site. See your Chrysler dealer for all the latest parts and accessories. You can learn more about the world of Mopar and all it has to offer at mopar.com



accessories

MOLDED RUNNING BOARDS.

Stylishly substantial boards feature a high-strength durable substructure that can take the pounding your family dishes out. Available in select body colors.



CHROMED BILLET ALUMINUM GRILLE INSERT.

Make your grille stand out with this custom design that features chromed billet aluminum for durability and a unique diamond design.



HITCH RECEIVER.*

Built for the long haul, this hitch receiver allows you to tow up to 1,800 lb. Ball Mount, Hitch Ball, Wiring Harness and Hitch Plug sold separately.

SPARE TIRE KIT.

You'll always be prepared in case you get a flat, wherever you are. This kit has all the right tools to help make installing a spare tire easy and convenient.



MOPAR WEB.¹²

Get high-speed Internet in your vehicle. Mopar Web's in-vehicle router receives broadband Internet, allowing passengers to surf the Web, social-network, look up directions, check email, play online games or download music. Works with any WiFi-enabled device. No cell cards or software required. Subscription required. Sold separately.

THE CHRYSLER COLLECTION

Bring the Chrysler brand style and distinction to your lifestyle in and out of your vehicle with authentic professional, active, travel and home accessories and apparel for your favorite Chrysler enthusiast. You'll also wear your pride-of-ownership attitude on your sleeve when you boast one of the popular Imported From Detroit™ items. Shop the complete collection to show you know what earned luxury is all about at collection.chrysler.com and IFDstore.com



Women's Chrysler Emblem T-Shirt (Item# 1144P)

Women will enjoy the look and feel of this soft, smooth fine jersey t-shirt. A necessity for any wardrobe.

- Specifications
- Lightweight 4.5 oz. t-shirt
 - 100% ring-spun combed cotton fine jersey construction
 - Made in the U.S.A.
 - 1" x 1" rib set-in collar
 - Chrysler script shadow design (left upper chest); Chrysler wing design (back yoke)
 - Sizes: S-XL
 - Available in maroon

Chrysler Acrylic Tumbler (Item# 10N5K)

This innovative tumbler allows you to drink from anywhere on the rim.

- Specifications
- 16-ounce capacity
 - Push-bottom operation
 - 360-degree drinking spout
 - Hand washing recommended
 - Chrysler word vertically printed in black on one side
 - Available in grey



Chrysler New Era Fitted Cap (Item# 1143Y)

Finding a comfortable fit is easy with this stylish-looking fitted baseball cap.

- Specifications
- 90% polyester/10% spandex construction
 - Structured
 - Mid profile
 - Embroidered Chrysler wing design
 - Sizes: L/XL
 - Available in black



IFD Dog Tags (Item# 10GD2)

Custom pewter dog tags with die-cut eagle and map pattern on a 24" ball chain. Top tag has die-cut eagle and laser-etched Imported From Detroit logo; back tag has map of Detroit pattern etched. Arrives in velvet bag. Made in the U.S.A.



Women's Circle Scarf (Item# 10FE6)

A versatile infinity/continuous loop scarf that can be worn in many different ways. Imported From Detroit logo in repeat design throughout scarf. Available in black. Made in the U.S.A.



Men's IFD Black T-Shirt (Item# 102YT)

Do you have the know-how that runs generations deep? Prove it with this exceptionally soft, hard-working tee. Available in black and sizes S-2XL. Made in the U.S.A.

WARRANTIES

Chrysler vehicles are covered by a Chrysler Group LLC 3-Year or 36,000-Mile Basic Limited Warranty (excludes normal maintenance and wear items), as well as a 5-Year or 100,000-Mile Powertrain Limited Warranty that is fully transferable and includes Roadside Assistance services: Flat Tire, Lockout, Towing, Out of Gas/Fuel Delivery and Battery Jump Assistance. Ask your dealer for details and a copy of these limited warranties.

AUTOMOBILITY

The Chrysler Group LLC Automobility program provides aftermarket reimbursement incentives on adaptive vehicle upfit equipment in order to help provide safe and reliable vehicle modifications to enhance accessibility for all people. For more information, call (800) 255-9877 or visit chryslerautomobility.com

SIRIUSXM® SATELLITE RADIO²

SiriusXM Satellite Radio² delivers over 150 channels, including commercial-free music, sports, news, talk, entertainment, traffic and weather. Factory-installed SiriusXM Satellite Radio² includes a one-year subscription. For more information, go to siriusxm.com

MOPAR® OWNER CONNECT®

Your Chrysler vehicle ownership gives you the credentials to access a secure "owners-only" Web site. Once registered, you'll gain online access to your service records, extensive vehicle information and exclusive special offers. Owners are invited to register their Chrysler vehicle at moparownerconnect.com



Earn 3 points per \$1 on qualifying purchases made at Chrysler Group LLC dealerships, 2 points per \$1 on qualifying travel purchases and 1 point per \$1 on qualifying purchases everywhere else with the new Chrysler MasterCard.® Points may be redeemed at your local dealership for cash off your new or used vehicle, accessories, parts or service — including your next oil change. Or choose from hundreds of other rewards, including travel, cash back to your account, merchandise or gift cards.¹⁴ For more information or to apply, visit ChryslerCard.com

MOPAR VEHICLE PROTECTION® (MVP)

Mopar Vehicle Protection (MVP) has a vested interest in your satisfaction and owner experience with your new Chrysler vehicle. MVP is the only extended protection provider backed by the manufacturer, Chrysler Group LLC. We stand behind every MVP plan with certified, factory-trained technicians and the use of authentic Mopar parts. Your plan is honored at over 2,600 dealerships within the United States, Canada, Puerto Rico and Mexico. Be sure to ask for a Mopar Vehicle Protection plan at your dealership, call (800) 442-2666 or visit moparvehicleprotection.com

JOIN IN

Join fellow enthusiasts and tell your story by posting comments, participating in discussions and sharing your Chrysler vehicle photos and videos. Join our community on Facebook (facebook.com/Chrysler), follow us on Twitter (twitter.com/Chrysler), Google+ (plus.google.com/+Chrysler), Instagram (instagram.com/Chrysler), Pinterest (pinterest.com/Chrysler) and check us out on YouTube (youtube.com/TheChryslerChannel). Thank you for following.

GO MOBILE

Take an engaging, multimedia tour of your Town & Country on your mobile device. Log on to the Chrysler.com mobile site for a comprehensive, at-a-glance review of what you need to know about your vehicle. Experience interactive demonstrations of the entire lineup, gaining access to product information at your fingertips, wherever you go.

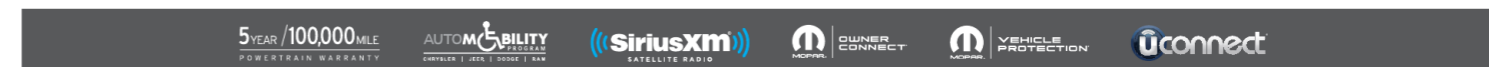

(1) Requires a mobile phone equipped with the Bluetooth Hands-Free Profile (HFP). Visit UconnectPhone.com for system and device compatibility. (2) SiriusXM audio and data services each require a subscription after the trial included with the new vehicle purchase, sold separately or as a package, by SiriusXM Radio Inc. If you decide to continue service after your trial, the subscription plan you choose will automatically renew thereafter and you will be charged according to your chosen payment method at then-current rates. Fees and taxes apply. To cancel, you must call SiriusXM at 1-866-635-2349. See SiriusXM Customer Agreement for complete terms at www.siriusxm.com. All fees and programming subject to change. © 2014 SiriusXM Radio Inc. Sirius, XM and all related marks and logos are trademarks of SiriusXM Radio Inc. (3) The SiriusXM Travel Link data displays and individual product availability vary by vehicle hardware. Not all vehicles or devices are capable of receiving all Travel Link services offered by SiriusXM; Weather Forecast and Current Conditions may not be available in all locations and features of individual systems will vary. Images shown are for representative purposes only and are not real products. For actual features and images of real products, consult the vehicle manufacturer. SiriusXM is not responsible for any errors or inaccuracies in the SiriusXM Travel Link services or their use. Our satellite service is available only to those at least 18 and older in the 48 contiguous U.S.A. and DC. Our Sirius satellite service is also available in PR (with coverage limitations). Our Internet radio service is available throughout our satellite service area and in AK and HI. (4) The advanced front air bags in this vehicle are certified to the new U.S. federal regulations for advanced air bags. Children 12 years old and younger should always ride buckled up in a rear seat. Infants in rear-facing child restraints should never ride in the front seat of a vehicle with a passenger front air bag. All occupants should always wear their lap and shoulder belts properly. (5) Always check visually for vehicles prior to changing lanes. (6) Always look before proceeding. An electronic drive aid is not a substitute for conscientious driving. Always be aware of your surroundings. (7) Based on the latest available competitive information and the Chrysler Group LLC Premium Minivan segment. (8) No system, no matter how sophisticated, can repeal the laws of physics or overcome careless driving actions. Performance is limited by available traction, which snow, ice and other conditions can affect. When the ESC warning lamp flashes, the driver needs to use less throttle and adapt speed and driving behavior to prevailing road conditions. Always drive carefully, consistent with conditions. Always wear your seat belt. (9) Based on 2001 through 2013 model year repurchase rates. (10) Detects most obstacles. As with all electronically controlled systems, care is advised. (11) Phone must support Bluetooth Phone Book Access Profile (PBAP). (12) Mopar Web feature is not intended for use by the driver while the vehicle is in motion. Always drive carefully. Subscription required. (13) Always sit properly with the head restraint properly adjusted. Never place anything in front of the head restraint. (14) Complete details, including restrictions, limitations and exclusions, will be available when you become a Cardmember. MasterCard is a registered trademark of MasterCard International Incorporated. This card is issued by First Bankcard, a division of First National Bank of Omaha, pursuant to a license by MasterCard International Incorporated.

© 2014 Chrysler Group LLC. All rights reserved. This brochure is a publication of Chrysler Group LLC. All product illustrations and specifications are based upon current information at the time of publication approval. Chrysler Group LLC reserves the right to make changes from time to time, without notice or obligation, in prices, specifications, colors and materials, and to change or discontinue models which are considered necessary to the purpose of product improvement or for reasons of design and/or marketing. Chrysler, the Chrysler wing design, Imported From Detroit, Mopar, Mopar Owner Connect, Mopar Vehicle Protection, ParkSense, ParkView, Pentastar, Sentry Key, Stow 'n Go, Stow 'n Place, Town & Country and Uconnect are registered trademarks, and SafetyTec is a trademark of Chrysler Group LLC. Alcantara is a registered trademark of Alcantara S.p.A. Alpine and the Alpine logo are registered trademarks of Alpine Electronics, Inc. All rights reserved. Bluetooth is a trademark of Bluetooth SIG, Inc. Blu-ray Disc is a registered trademark of Blu-ray Disc Association. Disney is a registered trademark of Disney. All rights reserved. Facebook and logo are trademarks of Facebook, Inc. Garmin and the Garmin logo are registered trademarks of Garmin, Ltd. or its subsidiaries and are registered in one or more countries, including the U.S. Gracenet and MusicID are registered trademarks of Gracenet, Inc. in the United States and/or other countries. Instagram is a registered trademark of Instagram, Inc. Michelin is a registered trademark of Michelin North America, Inc. iPad, iPhone, iPod and iTunes are registered trademarks of Apple Inc. Pinterest is a registered trademark of Pinterest, Inc. Sirius, XM and all related marks and logos are trademarks of SiriusXM Radio Inc. © 2014 SiriusXM Radio Inc. The Twitter name, logo, Twitter T, Tweet and Twitter bird are trademarks of Twitter, Inc. in the United States and other countries. Xbox 360 is a registered trademark of Microsoft. YouTube and Google+ social service are registered trademarks of Google Inc.

*Check User Guide for hitch type, load capacity and heavy-duty equipment required. Do not exceed rated tow capacity of the vehicle as equipped. Trailer may require some items not supplied by Mopar.



T&C LX

SELECT STANDARD EQUIPMENT

- 3.6L V6 Pentastar® Engine (283 hp/260 lb-ft)
- Leather-trimmed Seating
- Media Center 430 Radio with Back-Up Camera⁶
- Uconnect™ Voice Command¹
- Manual Three-zone HVAC
- Stow N Place® Roof Rack
- Power Sliding Doors/Liftgate¹⁰
- Stow 'n Go® Seating
- Front-seat Side Air Bags⁴
- Steering Wheel-mounted Audio and Cruise Controls
- Sunscreen Glass
- Power Locks
- Power 2nd-row Windows
- Power 3rd-row Vents
- 6 Speakers
- 17-inch Aluminum Wheels



T&C TOURING

SELECT STANDARD EQUIPMENT OVER LX

- Single DVD
- Automatic Three-zone HVAC
- Fog Lamps
- Auto Headlamps
- Power 8-way Driver's Seat
- Chrome Bodyside Molding
- Remote USB Port – Charge Only



T&C S

SELECT STANDARD EQUIPMENT OVER TOURING

- Leather-trimmed Seats with Fabric Inserts and Silver Stitching
- 17-inch Hyper Black Aluminum Wheels
- Blacked-out Headlamps
- Black Chrome Grille
- Piano Black Interior Accents
- "S" Badging
- Super Console
- Dual Blu-ray/DVD



T&C TOURING-L

SELECT STANDARD EQUIPMENT OVER TOURING

- Perforated Leather-trimmed Seats
- 2nd- and 3rd-row Window Shades
- Power Passenger Seat
- 17-inch Painted Aluminum Wheels
- Chrome Mirrors with Signals
- SafetyTec™ Package
- Blind Spot Monitoring⁵
- Rear Cross-Path Detection⁶
- Rain-sensing Wipers
- Premium Tire Pressure System
- Auto High-Beam Headlamp Control
- Rear Park Assist⁶



T&C LIMITED

SELECT STANDARD EQUIPMENT OVER TOURING-L

- Alcantara® Suede and Leather-trimmed Seats
- Super Console
- 17-inch Polished Aluminum Wheels
- Heated 1st- and 2nd-row Seats
- Heated Steering Wheel
- Power 3rd-row Folding Seat
- Power Folding Mirrors
- Navigation



T&C LIMITED PLATINUM

SELECT STANDARD EQUIPMENT OVER LIMITED

- 9 Speakers with 506-watt Amplifier
- Nappa Premium Leather-trimmed Seats
- Memory – Seats, Mirrors, Power Adjustable Pedals
- Heated Wood/Leather-wrapped Steering Wheel
- High Intensity Discharge (HID) Headlamps
- Dual Blu-ray/DVD
- Chrome Roof Rack
- Sunroof

COLORS AND FABRICS

EXTERIOR PAINT COLORS: BRIGHT WHITE, BRILLIANT BLACK CRYSTAL PEARL, MOCHA JAVA PEARL, TRUE BLUE PEARL, GRANITE CRYSTAL METALLIC, BILLET SILVER METALLIC, DEEP CHERRY RED CRYSTAL PEARL AND CASHMERE PEARL

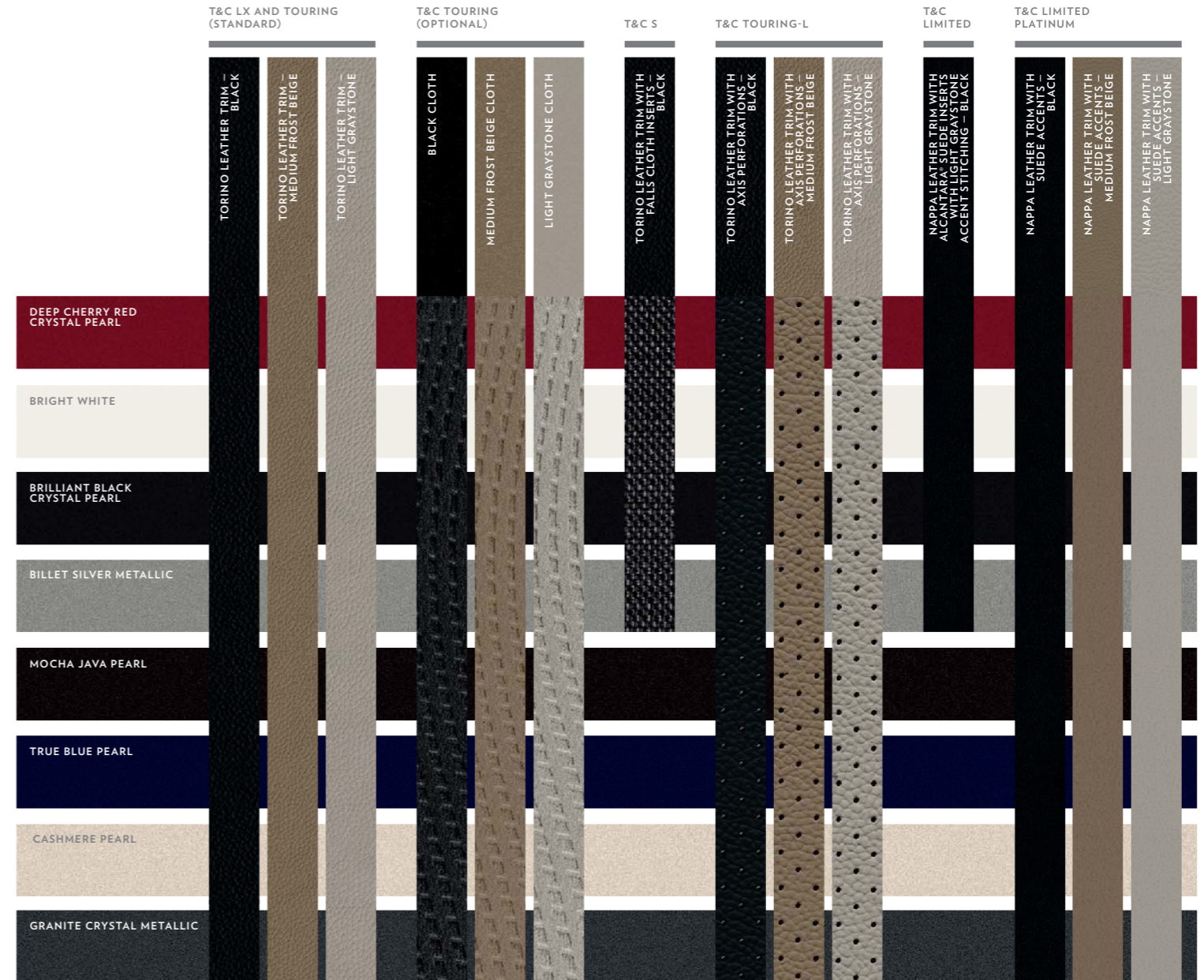

WHEELS



TOWN & COUNTRY LX & TOURING STANDARD
17-INCH ALUMINUM



TOWN & COUNTRY S STANDARD
17-INCH HYPER BLACK ALUMINUM



TOWN & COUNTRY TOURING-L STANDARD
17-INCH PAINTED ALUMINUM



TOWN & COUNTRY LIMITED AND LIMITED PLATINUM STANDARD
17-INCH POLISHED ALUMINUM



TOWN & COUNTRY LIMITED PLATINUM STANDARD
17-INCH SATIN SILVER ALUMINUM (LATE AVAILABILITY)



2015 CHRYSLER TOWN & COUNTRY
1.800.CHRYSLER / CHRYSLER.COM

Research

[BUILD & PRICE](#)

[COMPARE MODELS](#)

[COMPETITIVE COMPARE](#)

[SIGN UP FOR UPDATES](#)

Locate

[FIND A DEALER](#)

[SCHEDULE A TEST DRIVE](#)

Cost

[VIEW INCENTIVES & OFFERS](#)



CHRYSLER.COM

74-383-2511

Chrysler is a registered trademark of Chrysler Group LLC.