

STAY CONNECTED

VISIT US ONLINE TO CREATE YOUR IDEAL INFINITI

www.infiniti.com

JOIN OUR COMMUNITY, AND GET THE LATEST INFO

 [Facebook.com/infiniti](https://www.facebook.com/infiniti)

 [Instagram.com/infinitiusa](https://www.instagram.com/infinitiusa)

 [Twitter.com/infinitiusa](https://www.twitter.com/infinitiusa)

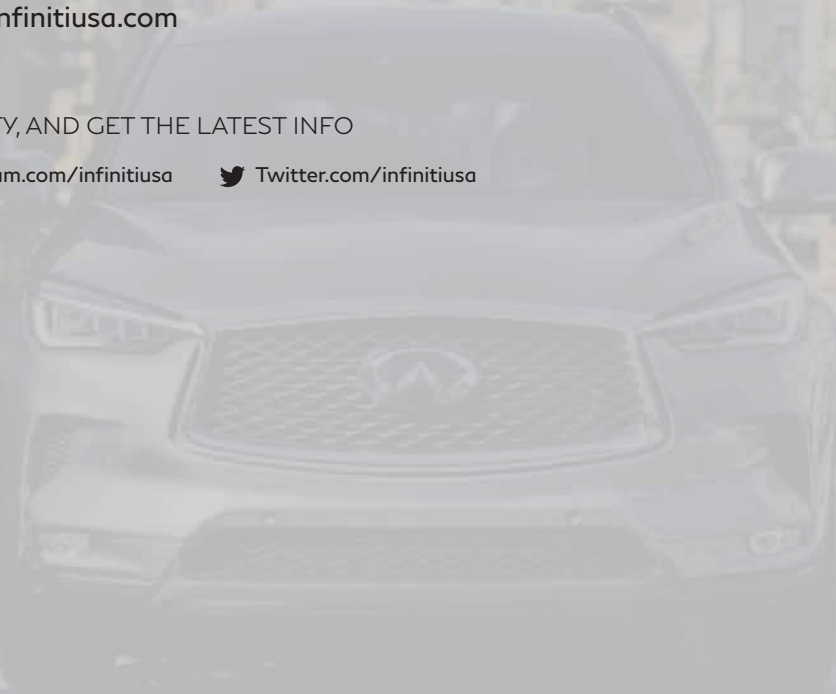

2020
QX50



INFINITI
EMPOWER THE DRIVE®

This brochure is intended for general descriptive and informational purposes only. It is subject to change and does not constitute an offer, representation or warranty (express or implied) by Nissan North America, Inc. Interested parties should confirm the accuracy of any information in this brochure as it relates to a vehicle directly with an INFINITI Retailer before relying on it to make a purchase decision. Nissan North America, Inc. reserves the right to make changes, at any time, without prior notice, in prices, colors, materials, equipment, specifications, and models and to discontinue models or equipment. Due to continuous product development and other pre- and post-production factors, actual vehicle, materials and specifications may vary from this brochure. Some vehicles shown with optional equipment. See the actual vehicle for complete accuracy. Availability and delivery times for particular models or equipment may vary. Specifications, options and accessories may differ in Hawaii, U.S. territories and other countries. For additional information on availability, options or accessories, see your INFINITI Retailer or visit INFINITI website.

Final production vehicle may vary. Always wear your seat belt, and please don't drink and drive. ©2019 INFINITI. IN-01594 Reorder #205021 (9/19, 15K, CC) ♻️ Reducing our environmental footprint is an important goal at INFINITI. That's why this brochure uses paper stock that is certified to contain a minimum of 10% post-consumer waste materials.

FINALLY, LIFE AND LUXURY ARE ON THE SAME PAGE



Only something stunning and breakthrough could bring life and luxury together. Something like the 2020 INFINITI QX50, where next-generation performance technology and uncompromising design form a vibrant collaboration. This is performance that anticipates future scenarios and it's like nothing you've ever driven. An INFINITI world's first production variable compression turbo engine² delivers what many thought was impossible: optimal power and efficiency in one engine. INFINITI drive assist technologies complement your natural abilities, letting you drive with less stress so you can do more than you could alone. A flagship interior embodies the perfect fit of color, contrast and premium materials, while a sliding second-row seat accommodates changing needs.³ When a premium crossover is as useful as it is progressive, you're at your best. Because it's not about luxury, but what you do with it that counts.

LUXURY SHOULD BE LIVED IN



▲ ROLL WITH DISTINCTION **1** 19 X 7.5-inch Silver-Painted Aluminum-Alloy Wheels **2** 20 X 8.5-inch Silver-Painted and Machine-Finished Aluminum-Alloy Wheels** **3** 20 X 8.5-inch Dark-Painted Aluminum-Alloy Wheels**



▲ A BALANCE OF ENERGY AND PURPOSE At a glance, the QX50 appears seamless and sculptural, but upon closer inspection, you'll see a blend of distinctive proportions and innovation. A clamshell hood design, that wraps over the fenders, creates a feeling of flowing power. A large wheel-to-body ratio translates into an athletic stance,¹ while eye-inspired LED headlights on the ProASSIST Package look to the future through an angled cube design.¹



▲ EVOLVE YOUR DRIVE Autonomous vehicles are coming to our highways. ProPILOT Assist,^{1,4} available on QX50 SENSORY, supports drivers with the same drive assist technologies that will inspire and empower you in the future. When activated, these innovations help you stay centered in the lane, navigate stop-and-go highway traffic,⁴ set vehicle speed and keep a set distance to the vehicle ahead.⁵ To help minimize stress and increase awareness of posted speed limits, Traffic Sign Recognition⁶ gives you a reminder on your instrument panel, Head-Up Display¹ and top navigation screen.^{1,7}

*INFINITI has taken care to ensure that the color swatches presented here are the closest possible representations of actual vehicle colors. Swatches may vary slightly due to the printing process and whether viewed in daylight, fluorescent or incandescent light. Please see the actual colors at your local INFINITI Retailer.**Additional cost applies for this option.

EXTERIOR COLORS*



▲ PAINT WITH PERSONALITY From sophisticated to dynamic, color inspires your own personal style.

INTERIOR COLOR/MATERIAL*

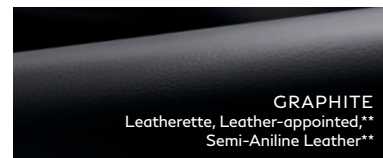

GRAPHITE
Leatherette, Leather-appointed,**
Semi-Aniline Leather**

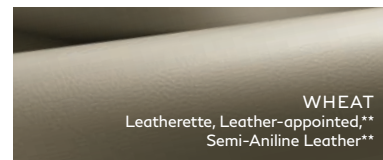

WHEAT
Leatherette, Leather-appointed,**
Semi-Aniline Leather**



WHITE
Semi-Aniline Leather**

INTERIOR TRIM*



PAINTED ALUMINUM

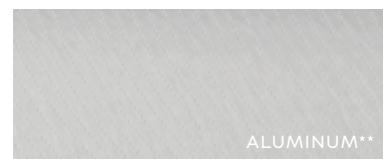

ALUMINUM**



NATURAL MAPLE WOOD**

^ EVERY CHOICE IS BOLD A rich and modern palette is the foundation for a premium space. Engage the senses with a striking combination of sight and touch.

SPACE FOR SELF-EXPRESSION

To live authentically, you have to free yourself from self-limiting beliefs. Enter the QX50, which lets you be as expressive as you desire. High-quality materials, contrasting textures and a multi-tone color combination tap into your creative instincts. Quilted white semi-aniline leather-appointed seats on QX50 AUTOGRAPH heighten your sense of beauty and artistry as they support you from one adventure to the next.¹ An interior that's revealing, flexible and generous enough to make room for your true nature welcomes the many ways you share yourself with the world.

*INFINITI has taken care to ensure that the color swatches presented here are the closest possible representations of actual vehicle colors. Swatches may vary slightly due to the printing process and whether viewed in daylight, fluorescent or incandescent light. Please see the actual colors at your local INFINITI Retailer. **Additional cost applies for this option.



▼ POWER OR EFFICIENCY? YES.

The INFINITI VC-Turbo™ is the first production variable compression turbo to continually transform for optimal power and efficiency.² The secret is



its unique multi-link system that varies the engine compression ratio between 8:1 for more power to 14:1 for greater mileage. Today, the choice between a powerful engine or an efficient one is over. Have both.



INFINITI InTouch™ featuring Apple CarPlay® integration^{9,10}

ADAPTING TO CHANGE A sliding and reclining second-row seat can give you the room – and flexibility – you need by moving forward and back almost six inches.^{3,8} For help opening the trunk, opt for the Motion-Activated Liftgate¹ on QX50 AUTOGRAPH.

IN SYNC WITH YOUR LIFE The INFINITI InTouch™ system allows you to use your compatible iPhone® with Apple CarPlay®. Or make your Android Auto™ compatible phone your preferred driving companion. Navigation provides real-time traffic information and turn-by-turn directions while enhanced Wi-Fi transforms QX50 into a high-speed hotspot.^{1,7,9,10}

TECH THAT HELPS LOOK OUT FOR YOU

As automotive technology becomes more advanced, we are striving to find new ways to anticipate the dangers around you. Many are INFINITI world's first technologies like Predictive Forward Collision Warning,⁵ which can alert you to a potential collision two cars ahead. Around View® Monitor with Moving Object Detection,¹⁰ on QX50 ESSENTIAL, which uses four cameras and one virtual composite 360° view to elevate parking.¹¹ Finally, Blind Spot Intervention® on the ProASSIST Package helps detect cars in your blind spot area and can intervene to help avoid a collision.¹²



Forward Emergency Braking with Pedestrian Detection¹⁴

TRIM LEVELS & PACKAGES

QX50 PURE	QX50 LUXE	QX50 ESSENTIAL	QX50 SENSORY	QX50 AUTOGRAPH
<p>MECHANICAL AND PERFORMANCE</p> <ul style="list-style-type: none"> 2.0L VC-Turbo™ 4-cylinder engine (268-hp @ 5,600 rpm, 280 lb-ft @ 1,600-4,800 rpm) Continuously Variable Transmission with manual shift mode Front-Wheel Drive or INFINITI Intelligent All-Wheel Drive¹⁵ <p>DESIGN</p> <ul style="list-style-type: none"> LED automatic-on/off headlights LED signature Daytime Running Lights 19-inch silver-painted aluminum-alloy wheels with 235/55R19 run-flat, all-season tires Body-color, manual folding and power adjustable outside mirrors Body-color door handles with chrome accent Front door handle courtesy lights Rear privacy glass <p>CRAFTSMANSHIP</p> <ul style="list-style-type: none"> Leatherette seating Painted aluminum interior trim accents 60/40-split fold-down rear seatbacks with slide and recline^{3,8} Leather-wrapped steering wheel with paddle shifters and leather-accented shifter 10-way power adjustable driver's seat, including 2-way power lumbar 8-way power adjustable front passenger's seat Dual zone Automatic Temperature Control System 	<p>TECHNOLOGY</p> <ul style="list-style-type: none"> INFINITI InTouch™ dual display system, with upper 8-inch and lower 7-inch LCD touch-screen displays^{9,10} HD Radio® Technology 6-speaker audio system with AM/FM radio and CD player Apple CarPlay® integration for your compatible iPhone^{9,10} Android integration for your Android Auto™ compatible phone^{9,10} Bluetooth® Hands-free Phone System, audio streaming^{9,10} 4 USB charging ports¹⁶ SiriusXM® Radio with Advanced Audio features^{9,10} INFINITI Intelligent Key with Push Button Ignition Electronic parking brake Power rear liftgate INFINITI Intelligent Key with Illuminated Push Button Start Rear Sonar System¹⁷ <p>SAFETY</p> <ul style="list-style-type: none"> Forward Emergency Braking with Pedestrian Detection¹⁴ Predictive Forward Collision Warning⁵ High Beam Assist headlights Lane Departure Warning¹⁸ Blind Spot Warning¹⁹ Rear Automatic Braking²⁰ RearView Monitor²¹ Rear Cross Traffic Alert²² <p>Includes all QX50 PURE standard features, plus:</p> <p>DESIGN</p> <ul style="list-style-type: none"> Power sliding/tilting panoramic moonroof and power sliding sunshade Roof rails²³ LED front fog lights <p>CRAFTSMANSHIP</p> <ul style="list-style-type: none"> Textured aluminum interior trim accents <p>TECHNOLOGY</p> <ul style="list-style-type: none"> Remote Engine Start²⁴ Auto-dimming rearview mirror with HomeLink® Universal Transceiver <p>Optional Packages: 7 8</p>	<p>Includes all QX50 LUXE standard features, plus:</p> <p>DESIGN</p> <ul style="list-style-type: none"> Heated outside mirrors <p>CRAFTSMANSHIP</p> <ul style="list-style-type: none"> Heated front seats <p>TECHNOLOGY</p> <ul style="list-style-type: none"> INFINITI InTouch™ Navigation with 3D building graphics, 5-year complimentary access to Premium Traffic and MapCare^{7,9,10} Automatic Collision Notification and Emergency Call^{9,10} SiriusXM® Traffic with 3-month trial access to real-time traffic information^{9,10} SiriusXM® Travel Link with 3-month trial access to Weather, Fuel Prices, Stock Prices, Sport Scores, Movie Listings and Parking^{9,10} INFINITI InTouch™ with Wi-Fi Hotspot^{9,10} Front Sonar System¹⁷ Rain-sensing wipers <p>SAFETY</p> <ul style="list-style-type: none"> Around View® Monitor with Moving Object Detection¹¹ <p>Optional Packages: 1 2 9</p>	<p>Includes all QX50 ESSENTIAL features, plus:</p> <p>DESIGN</p> <ul style="list-style-type: none"> 20-inch silver-painted, machine-finished aluminum-alloy wheels with 255/45R20 run-flat, all-season tires Unique cube design I-LED headlights (LED high/low beam) <p>CRAFTSMANSHIP</p> <ul style="list-style-type: none"> Leather-appointed, perforated seating Bose® Performance Series metallic speaker grilles on tweeters Heated, leather-wrapped steering wheel <p>TECHNOLOGY</p> <ul style="list-style-type: none"> Bose® Performance Series 16-speaker Premium Audio System, including subwoofer Adaptive Front Lighting System Power tilting and telescoping steering column Dual-occupant memory system for driver's seat, steering wheel and outside mirrors Outside mirrors with reverse tilt-down feature Distance Control Assist²⁵ <p>SAFETY</p> <ul style="list-style-type: none"> Intelligent Cruise Control²⁶ Blind Spot Intervention¹³ Lane Departure Prevention¹⁸ <p>Optional Packages: 3 4</p>	<p>Includes all QX50 SENSORY features, plus:</p> <p>DESIGN</p> <ul style="list-style-type: none"> 20-inch dark-painted aluminum-alloy wheels with 255/45R20 run-flat, all-season tires <p>CRAFTSMANSHIP</p> <ul style="list-style-type: none"> Climate-controlled front seats Rear side window sunshades Semi-aniline leather-appointed, perforated seating Natural Maple Wood interior trim accents Ultrasuede® headliner and pillars Black Ultrasuede® upper door, upper instrument panel, seat and center console lid accents (Graphite interiors only) 2-way passenger's power lumbar support Tri-Zone Automatic Temperature Control System <p>TECHNOLOGY</p> <ul style="list-style-type: none"> ProPILOT Assist: Lane Keep Assist and Intelligent Cruise Control with full speed range, stop & hold, and auto-resume^{4,26} Head-Up Display Direct Adaptive Steering® Traffic Sign Recognition^{6,10} Motion-Activated Liftgate²³ Enhanced LED interior ambient lighting <p>Optional Packages: 5 6</p>

PACKAGES

<p>1 PROASSIST PACKAGE</p> <p>Requires 2</p> <ul style="list-style-type: none"> Distance Control Assist²⁵ Intelligent Cruise Control²⁶ Blind Spot Intervention¹³ Lane Departure Prevention¹⁸ Unique cube design LED headlights (LED high/low beam) Adaptive Front Lighting System 	<p>3 PROACTIVE PACKAGE</p> <p>Requires 4</p> <ul style="list-style-type: none"> ProPILOT Assist: Lane Keep Assist and Intelligent Cruise Control with full speed range, stop & hold, and auto-resume^{4,26} Head-Up Display 	<p>4 CLIMATE PACKAGE</p> <ul style="list-style-type: none"> Climate-controlled front seats Rear side window sunshades Tri-Zone Automatic Temperature Control System 	<p>5 PREMIUM WHITE LEATHER PACKAGE</p> <ul style="list-style-type: none"> White semi-aniline leather-appointed seating with quilting Blue Ultrasuede® interior accents Brown Ultrasuede® headliner and pillars Blue piping accents 	<p>6 TOW PACKAGE²⁷</p> <p>AUTOGRAPH AWD models only.</p> <ul style="list-style-type: none"> 3,000-lb. maximum towing capacity Tow hitch, receiver and wiring harness
<p>2 CONVENIENCE PACKAGE</p> <ul style="list-style-type: none"> Leather-appointed, perforated seating Power tilting and telescoping steering column Dual-occupant memory system for driver's seat, steering wheel and outside mirrors Outside mirrors with reverse tilt-down feature Heated steering wheel 	<p>8 NAVIGATION PACKAGE</p> <p>Requires 7</p> <ul style="list-style-type: none"> INFINITI InTouch™ Navigation with 3D building graphics, 5-year complimentary access to Premium Traffic and MapCare^{7,9,10} SiriusXM® Traffic with 3-month trial access to real-time traffic information^{9,10} SiriusXM® Travel Link with 3-month trial access to Weather, Fuel Prices, Stock Prices, Sport Scores, Movie Listings and Parking^{9,10} INFINITI InTouch™ with Wi-Fi Hotspot^{9,10} 	<p>9 EDITION 30 PACKAGE²⁸</p> <p>Requires 1. Cannot be combined with 2 3 4 5 6 7 8</p> <ul style="list-style-type: none"> "EDITION 30" badge "EDITION 30" front illuminated stainless steel kick plates Dark chrome exterior accents - grille surround, front fender accent, and liftgate finisher 20-inch dark finish aluminum-alloy wheels with 255/45R20 run-flat, all-season tires Black grille mesh Black mirror caps Body color rear diffuser Graphite headliner, sun visors, and pillars 	<p>7 HEATED SEATS PACKAGE</p> <p>Requires 8</p> <ul style="list-style-type: none"> Heated front seats 	



1 CHROME BODY SIDE MOLDINGS 2 20-INCH WHEELS

▲ **EXTERIOR** Style without pretense. Designed with functionality in mind, Chrome Body Side Moldings underscore the powerful lines of your QX50 while protecting your side panels. Large 20-inch wheels enhance another aspect of your vehicle – its athletic stance. When you're on the go, a Lifestyle Receiver Mount for 2-inch mounted carriers accommodates bikes and snowboards.²³ Every accessory amplifies the true nature of your INFINITI.

▼ **INTERIOR** Take life with you. Keep your purse or tablet close by with a Console Net located inside the cabin. Out in the elements? Embrace your adventurous nature with All-Season Floor Mats that collect dirt and sand, preserving your interior footwells. Sometimes, life is full of imperfect moments. Keep your QX50 protected with a Stainless Steel Rear Bumper Protector that guards against scrapes when loading and unloading cargo.



3 ALL-SEASON FLOOR MATS
4 STAINLESS STEEL REAR BUMPER PROTECTOR



GENUINE INFINITI ACCESSORIES FOR WHAT'S POSSIBLE

Life is filled with possibilities. Genuine INFINITI Accessories²⁹ can empower you to turn the 'what-ifs' into reality. Each accessory is made with exacting standards, the same ones we utilize when building your INFINITI QX50.

This approach ensures each item is designed and manufactured to integrate seamlessly with your vehicle and provide a custom fit and finish. For more information and to shop online for Genuine INFINITI Accessories, go to parts.infiniti.com.

ACCESSORIES SHOWN: ROOF RAIL CROSSBARS AND YAKIMA® FRONTLOADER^{23,30}

▼ **CARGO** Hold virtually anything, including memories. Cargo Block Stabilizers and a Cargo Mat work together to secure bulky items from sliding or tipping. While a Cargo Organizer keeps the stuff of memories neatly arranged.²³



1 CARGO ORGANIZER²³
2 INFINITI RADIANT ILLUMINATED KICK PLATES

▲ **LIGHTING** Illuminate elegance with signature lighting accessories. The effect lends an upscale ambience and offers a modern appeal that is unmistakable. From the soft glow of the INFINITI logo along the front door sills to the drama of INFINITI Radiant Welcome Lighting, brilliance is all around. Turn it on.

ADDITIONAL ACCESSORIES TO CONSIDER:

- Remote Engine Start²⁴
- Silver-Painted Grille
- Hatch Tent
- Hideaway Cargo Net
- Carpeted Floor Mats
- Chrome Front Fascia Accents
- Chrome Front Lip Finisher
- Chrome Mirror Caps



^ CELEBRATE THE DIFFERENCES

One of the most compelling interiors to date, the QX50 AUTOGRAPH features exquisite craftsmanship, fine detail from stitching to surface finishes, and a tailored cabin brought to life with the Bose® Performance Series 16-speaker Premium Audio System.¹



FEED YOUR INDIVIDUALITY QX50 AUTOGRAPH WITH PREMIUM WHITE LEATHER

Inspiration can come from anywhere. Our designers went to the beach and were not only moved by its sheer beauty but also by the realization of how nature could impact design. Step inside the QX50 and a sense of wonder will nourish your spirit. You'll be greeted with a creamy off-white reminiscent of soft white-sand beaches, a chocolate brown as deep and rich as driftwood, and a dark blue evocative of ocean water. Together all three materials strike an inviting balance between warm and cool, creating an invigorating environment that is finished in semi-aniline leather appointments, contrast stitching and genuine open-pore wood. Sometimes the most inspirational places are intensely personal.

TECHNICAL SPECS

INTERIOR DIMENSIONS

Cargo volume ²³ – behind first-row – without / with panoramic moonroof (cubic feet)	65.1 / 64.4
Cargo volume ²³ – behind second-row – without / with panoramic moonroof (cubic feet)	31.4 / 31.1
Head room without panoramic moonroof – first-row / second-row (inches)	41 / 39.1
Head room with panoramic moonroof – first-row / second-row (inches)	40 / 38.4
Leg room – first-row / second-row (inches)	39.6 / 38.7

CAPACITY

Maximum tow capacity ²⁷	3,000 lbs
Fuel tank	16 gallons
Seating	5-passengers

FUEL ECONOMY

Estimated Fuel Economy FWD ³¹ – city / highway / combined (mpg)	23 / 29 / 26
Estimated Fuel Economy AWD ³² – city / highway / combined (mpg)	22 / 28 / 25

See infinitusa.com for complete list of specifications.

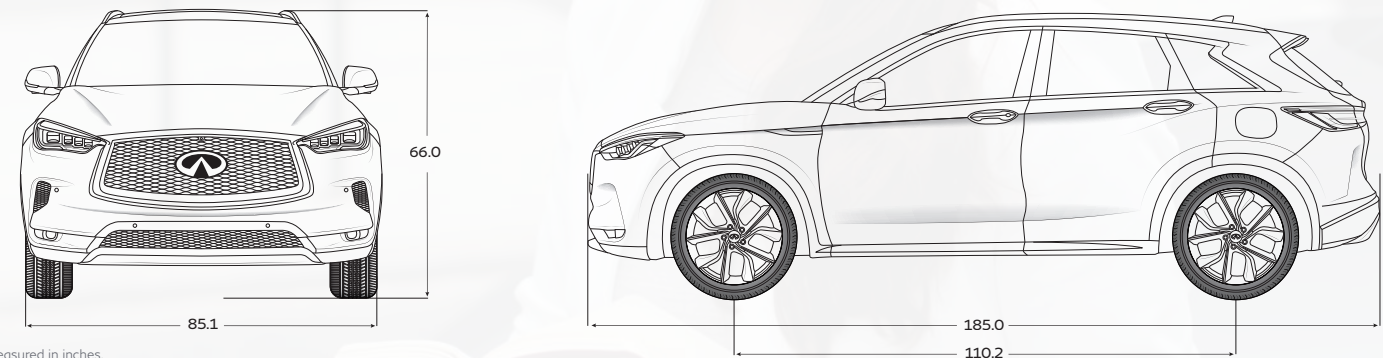

All dimensions are measured in inches.

¹Available on select models. ²VC-Turbo™ launched by INFINITI in model year 2019. ³Slide-forward function should not be performed with the Child Restraint System occupied. Do not ride in a moving vehicle when the seatback is reclined. For the most effective protection, the seat should be upright. See Owner's Manual for safety information. ⁴ProPILOT Assist cannot prevent collisions. It is the driver's responsibility to be in control of the vehicle at all times. Always monitor traffic conditions and keep both hands on the steering wheel. System operates only when lane markings are detected. Does not function in all weather, traffic and road conditions. System has limited control capability and the driver may need to steer, brake or accelerate at any time to maintain safety. See Owner's Manual for safety information. ⁵Predictive Forward Collision Warning is intended to warn you before a collision occurs; it cannot prevent a collision. Speed & other limitations apply. See owner's manual for details. ⁶Traffic Sign Recognition (TSR) may not detect and read all traffic signs in all conditions. Driver should monitor all traffic signs and obey all traffic laws. ⁷Never program while driving. GPS mapping may not be detailed in all areas or reflect current road status. ⁸Do not ride in a moving vehicle when the seatback is reclined. For the most effective protection, the seat should be upright. See Owner's Manual for safety information. ⁹Available services/features may be shown. Compatible connected device may be required. Only use services/features and device when safe and legal to do so. Subject to GPS and wireless network availability and connection, and system/technology limitations. Text rates/data usage/subscription may apply. Some services/features provided by companies not within Infiniti or its partners' or agents' control and may be discontinued at any time. For more information, see retailer, Owner's Manual, or www.infinitiUSA.com/intouch/important-information. ¹⁰If equipped, your vehicle may include INFINITI InTouch connected features and services such as Emergency Call and Automatic Collision Notification for one year, Wi-Fi, Navigation, Bluetooth and other connected features that can be viewed by model on the INFINITI InTouch website here: <https://www.infinitusa.com/intouch/system-details>. For complete information about your INFINITI InTouch features and services, please consult your vehicle's INFINITI InTouch Owner's Manual at <https://owners.infinitusa.com/owners/navigation/manualsAndGuides>. For more information, please visit <https://www.infinitusa.com/intouch/important-information>. Compatible connected device may be required. Subject to GPS and wireless network availability and connection, and system/technology limitations. INFINITI InTouch with Wi-Fi terms and conditions of subscriber agreement apply. ¹¹Around View Monitor with Moving Object Detection cannot completely eliminate blind spots and may not detect every object. MOD operates at vehicle speeds below 5 mph. Always check surroundings and turn to look behind you before moving vehicle. ¹²Virtual composite 360° view. ¹³Blind Spot Intervention cannot prevent all collisions and may not detect every object or warn in all situations. Driver should always turn and look before changing lanes. See Owner's Manual for safety information. ¹⁴Forward Emergency Braking with Pedestrian Detection cannot prevent all collisions and may not provide warning or braking in all conditions. Driver should monitor traffic conditions and brake as needed to prevent collisions. See Owner's Manual for safety information. ¹⁵Intelligent All-Wheel Drive cannot prevent collisions or provide enhanced traction in all conditions. Always monitor traffic and weather conditions. ¹⁶Driving is serious business and requires your full attention. If you have to use the connected device while driving, exercise extreme caution at all times so full attention may be given to vehicle operation. ¹⁷Sonar System may not detect every object. Driver should always check surroundings before driving. See Owner's Manual for safety information. ¹⁸Lane Departure Warning and Lane Departure Prevention only operate when lane markings are detectable. See Owner's Manual for safety information. ¹⁹Blind Spot Warning cannot prevent collisions and may not detect every object or warn in all situations. Driver should always turn and look before changing lanes. See Owner's Manual for safety information. ²⁰Rear Automatic Braking cannot prevent all collisions and may not provide warning or braking in all conditions. Driver should monitor traffic conditions and brake as needed to prevent collisions. See Owner's Manual for safety information. ²¹RearView Monitor may not detect every object and does not eliminate blind spots or warn of moving objects. See Owner's Manual for safety information. ²²Rear Cross Traffic Alert may not detect all vehicles. See Owner's Manual for safety information. ²³Cargo and load capacity limited by weight and distribution. Always secure all cargo. Heavy loading of the vehicle with cargo, especially on the roof, will affect the handling and stability of the vehicle. ²⁴State laws may apply. Review before using. ²⁵Distance Control Assist uses limited braking and is not a collision avoidance or warning system. Driver should monitor traffic conditions and brake as needed to prevent collisions. See Owner's Manual for safety information. ²⁶Intelligent Cruise Control uses limited braking and is not a collision avoidance or warning system. Driver should monitor traffic conditions and brake as needed to prevent collisions. See Owner's Manual for safety information. ²⁷Towing capacity varies by configuration. See INFINITI Towing Guide and Owner's Manual for additional information. ²⁸Edition 30 Package available late 2019. ²⁹Covered by INFINITI's Limited Warranty on Genuine INFINITI Accessories for the longer of 12 months/12,000 miles (whichever is earlier) or the remaining period under the 4-year/60,000-mile INFINITI New Vehicle Limited Warranty. Terms and conditions apply. See Warranty Information Booklet for details. ³⁰Cargo and load capacity limited by weight and distribution. Always secure all cargo. Heavy loading of the vehicle with cargo, especially on the roof, will affect the handling and stability of the vehicle. Yakima accessory is not a Genuine INFINITI Accessory. Not warranted by INFINITI. Refer to product manufacturer for warranty details. INFINITI Limited Warranty does not cover damages or failures to the vehicle caused by improper installation of any INFINITI-approved accessory or components. Contact your retailer for details. Yakima® is a registered trademark of Yakima Products, Inc. ³¹2020 QX50 FWD EPA Fuel Economy Estimates 23 City, 29 Highway. Actual mileage may vary with driving conditions – use for comparison only. ³²2020 QX50 AWD EPA Fuel Economy Estimates 22 City, 28 Highway. Actual mileage may vary with driving conditions – use for comparison only. Android® and Android Auto™ are trademarks of Google LLC. Apple CarPlay® is a registered trademark of Apple, Inc. Bluetooth® is a registered trademark of Bluetooth SIG, Inc. Bose® is a registered trademark of The Bose Corporation. HD Radio® is a registered trademark of iBiquity Digital Corporation. HomeLink® is a registered trademark of Gentex Corporation. iPhone® and iPod® are registered trademarks of Apple, Inc. All rights reserved. iPhone®, XM, and SiriusXM names and all related marks and logos are trademarks of Sirius XM Radio Inc. All other trademarks are the property of their respective owners.