



MASERATI

EXCELLENCE THROUGH PASSION

GRANCABRIO RANGE



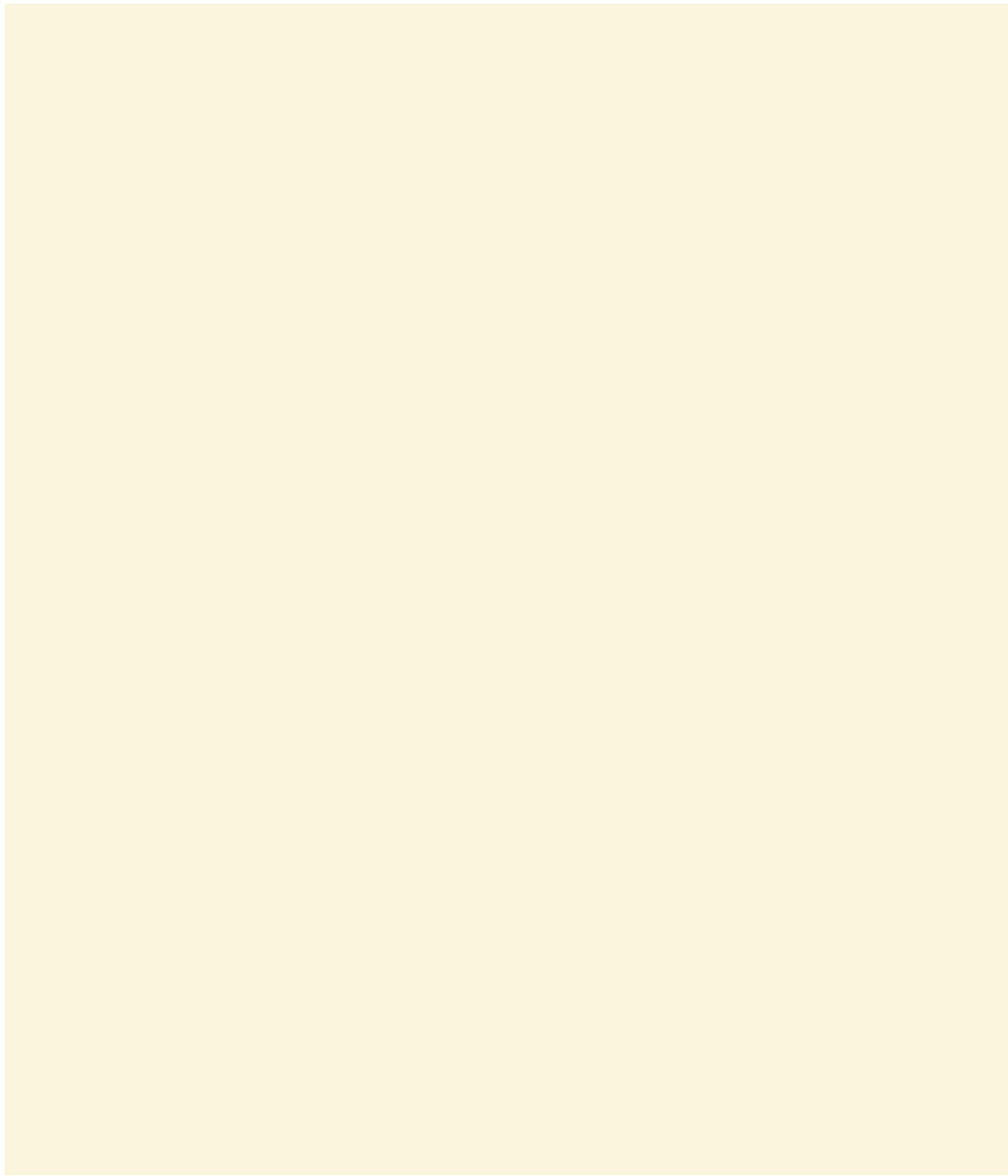

MASERATI

EXCELLENCE THROUGH PASSION

EVERY MASERATI IS A TRUE WORK OF ART, ITS PERFECTION EXPRESSING THE MARQUE'S PROUD HERITAGE AND ITS CURRENT PRESTIGE AND DISTINCTION. IN THESE INSPIRATIONAL CARS ARE FOUND BREATHTAKING STYLING, GROUNDBREAKING INNOVATION AND SUMPTUOUS LUXURY, ALL UNDERPINNED BY THE EXPERIENCE AND EXPERTISE OF THE HIGHLY SUCCESSFUL MASERATI CORSE RACING TEAM.

THROUGHOUT ITS LONG AND GLORIOUS EXISTENCE, MASERATI HAS ALWAYS BEEN SYNONYMOUS WITH POWER, PASSION, SOPHISTICATED AND REFINEMENT. BY CONTINUALLY STRIVING FOR EXCELLENCE IN EVERY LAST DETAIL IT HAS PLAYED A PIVOTAL ROLE IN ITALY'S PROUD AUTOMOTIVE HISTORY - ITS MISSION BEING TO DELIVER THE UNIQUE MASERATI MOTORING EXPERIENCE TO THE WORLD'S MOST DISCERNING DRIVERS.



MASERATI GRANCABRIO RANGE <i>THE OPEN-AIR EXPERIENCE</i>	6
MASERATI GRANCABRIO <i>EXPERIENCE MORE</i>	10
MASERATI GRANCABRIO SPORT <i>ELEVATE THE EXPERIENCE</i>	44
MASERATI GRANCABRIO RANGE <i>TWO PERSONALITIES, ONE SOUL</i>	70
THE ENTIRE MASERATI WORLD	108



Maserati

MO 145 SP MO



MASERATI GRAN CABRIO SPORT
ELEVATE THE EXPERIENCE

THE MASERATI GRANCABRIO RANGE

THE OPEN-AIR EXPERIENCE

WHEN PASSION MEETS INSPIRATION, THE OUTCOME IS ALWAYS SUBLIME, AND NOWHERE IS THIS BETTER EXEMPLIFIED THAN IN MASERATI'S RANGE OF CONVERTIBLES - THE GRANCABRIO AND GRANCABRIO SPORT. TO DRIVE THESE CARS IS A FEAST FOR THE SENSES: THEIR LOOKS ARE SIMPLY STUNNING, THEIR SOUNDS ARE UNFORGETTABLE, EVERY SURFACE IS EXQUISITE TO THE TOUCH, AND EVEN THEIR AROMA AROUSES SENSATIONS OF OPULENCE AND LUXURY. THEY ARE THE SUMMATION OF MASERATI'S LONG CHERISHED VALUES: IMMENSE POWER, INSPIRATIONAL HANDLING, AND ALL-ENVELOPING LUXURY: ABSOLUTE DRIVING PLEASURE, JUST WAITING TO BE EXPERIENCED.

MASERATI GRAN CABRIO
EXPERIENCE MORE





MASERATI GRANCABRIO

EXPERIENCE MORE

THERE'S SOMETHING VERY SPECIAL ABOUT DRIVING 'AL FRESCO'. IT'S ALL ABOUT BEING AT ONE WITH THE ENVIRONMENT, SAVOURING THE ESSENTIAL PLEASURES OF THE SURROUNDING LANDSCAPE AND REJOICING IN THE ENSUING SENSE OF FREEDOM. HOWEVER, A MASERATI GRANCABRIO IS NOT JUST A SENSUAL EXPERIENCE, IT IS A LIFESTYLE CHOICE, AS WELL. IT NOT ONLY MAKES A POWERFUL PERSONAL STATEMENT ABOUT THE OWNER BUT ALSO ALLOWS EVERYONE ONBOARD TO SHARE IN THE OCCASION. THE REAR SEATS, INDIVIDUALLY CRAFTED AND CONTOURED LIKE THOSE AT THE FRONT, PROVIDE A HIGHLY PERSONALISED AND INTIMATE SETTING FOR TWO FULL-SIZE ADULTS, BRINGING COMFORT AND PRACTICALITY TO A CAR WHOSE BADGE DENOTES AN IMPECCABLE RACING PEDIGREE.





EMOTIVE STYLE

The GranCabrio's elegant profile bears the unmistakable signature of Pininfarina. The imposing front end culminates in the horizontal headlights that emerge seamlessly from the front wings, whilst the centrepiece of the grill is a large chrome Maserati Trident. The drama of the side view is accentuated by short overhangs, a long bonnet, and striking 20" alloy wheels.

The rear of the Maserati GranCabrio gives further emphasis to the car's sportiness and advanced technology: the triangular light clusters comprise some 96 LEDs to ensure maximum night-time visibility. With the top up, the impression is of power, fluidity and muscularity, a look that is enhanced by new, rounded rear wings that match the aggressive look of the front. However, at the touch of a button the car's character is transformed: the roof disappears and a gorgeous new shape reveals itself, all in the space of just 28 seconds.





MASERATI GRAN CABRIO
EXPERIENCE MORE



The Maserati GranCabrio's unique spirit continues inside with a skilfully chosen blend of modernity, elegance, racing style and comfort – an interior to cosset the privileged few who will experience the GranCabrio, either as driver or passenger.

In the cabin, all the materials are worked with precision and skill by expert craftsmen in leather and wood; inspiration and perfection are the only ways to describe the Maserati GranCabrio's interior. The first thing to strike the eye is the dashboard, which is laid out horizontally and is highlighted by the central V-shape. The controls are located in such a way as to give the driver the feeling of total control: the major dynamic functions are controlled by buttons on the driver's side, whilst the most commonly used multimedia controls can be operated via those on the steering wheel. The functions are then displayed on the seven inch screen of the Maserati Multi Media System, which is mounted in the centre of the dashboard – in a raised position for improved visibility.

The all-round attention to detail manifests itself in numerous features, such as the subtle chrome inlay that elegantly decorates the buttons on the dashboard and steering wheel, the Trident emblem that is hand-crafted on the seat headrests, the Alcantara® trim that lines the back of the gearshift paddles, and the prominent hand-stitching of the front and rear armrests.







MASERATI GRAN CABRIO
EXPERIENCE MORE

MASERATI GRAN CABRIO
EXPERIENCE MORE





THE ULTIMATE IN COMFORT

The Maserati GranCabrio is the ultimate expression of open-top motoring, delivering to both driver and passengers an intimate relationship with the sights, sounds and smells of the surrounding landscape, along with a very special sense of freedom. Everyone on board will enjoy the unparalleled comfort in an elegant and luxurious environment.

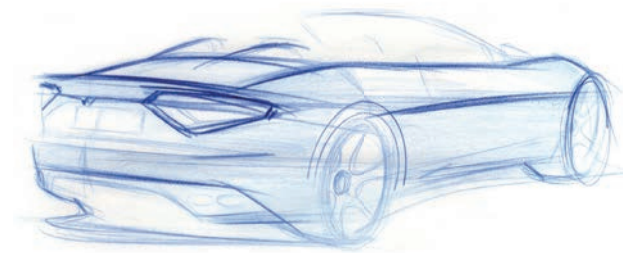

FRONT SEATS

Both front seats are fully electric, including the lumbar support adjustment. An optional comfort package includes seat position memories, a three-temperature seat heating system and an electrically adjustable steering column with an easy entry/exit function. This automatically raises and lowers the steering column when the door is opened, to help the driver get in and out more easily. The contours of the seats and the seatbacks have been designed to provide the torso and legs with plenty of support, especially during high speed cornering.

REAR SEATS

The seats in the rear of the GranCabrio are similar in design to those at the front and accommodate two adults in complete comfort. There are two cup-holders (mirroring those at the front) and a handy oddments receptacle located on the central tunnel. Once the occupants are in their seats, they find themselves in an extremely relaxing, slightly reclined position.







Maserati

MO 145 BD MO

HIGH-TECH LUXURY

The highly sophisticated engineering of the GranCabrio allows the driver to enjoy the driving experience to the full. And like all Maseratis, it conforms to the very highest levels of safety.





MASERATI GRAN CABRIO
EXPERIENCE MORE

AERODYNAMIC EFFICIENCY

The aerodynamics and styling of the car have been developed in tandem to minimise the airflow vortices that are unique to a cabriolet. The drag coefficient is only 0.35 with the top up, and 0.39 with top down – exceptional figures for an open top car. This has been achieved thanks to the special design of the floorpan and, of course, the overall styling of the body that minimises drag and maximises downforce.

WEIGHT DISTRIBUTION

What helps make the GranCabrio such fun to drive and so highly responsive is its finely balanced weight distribution. With the top up, 49% of the car's weight is carried by the front wheels and 51% by the rear wheels, whilst with the top down, the respective figures are 48% and 52%. This balance has been achieved by moving the engine back behind the front axle. It means that everyday driving becomes predictable, easy, and stress-free, with traction maximised when accelerating (particularly on low grip surfaces). Roadholding is improved, too, whilst the car remains exceptionally stable and well balanced even during emergency manoeuvres.

The perfect balance of the GranCabrio is further enhanced by the hydraulic gearbox being integrated into the engine block, and by the dual-section transmission shaft, which delivers torque to the wheels via a self-locking differential (25% lock in traction, 45% in release) to limit any loss of grip.

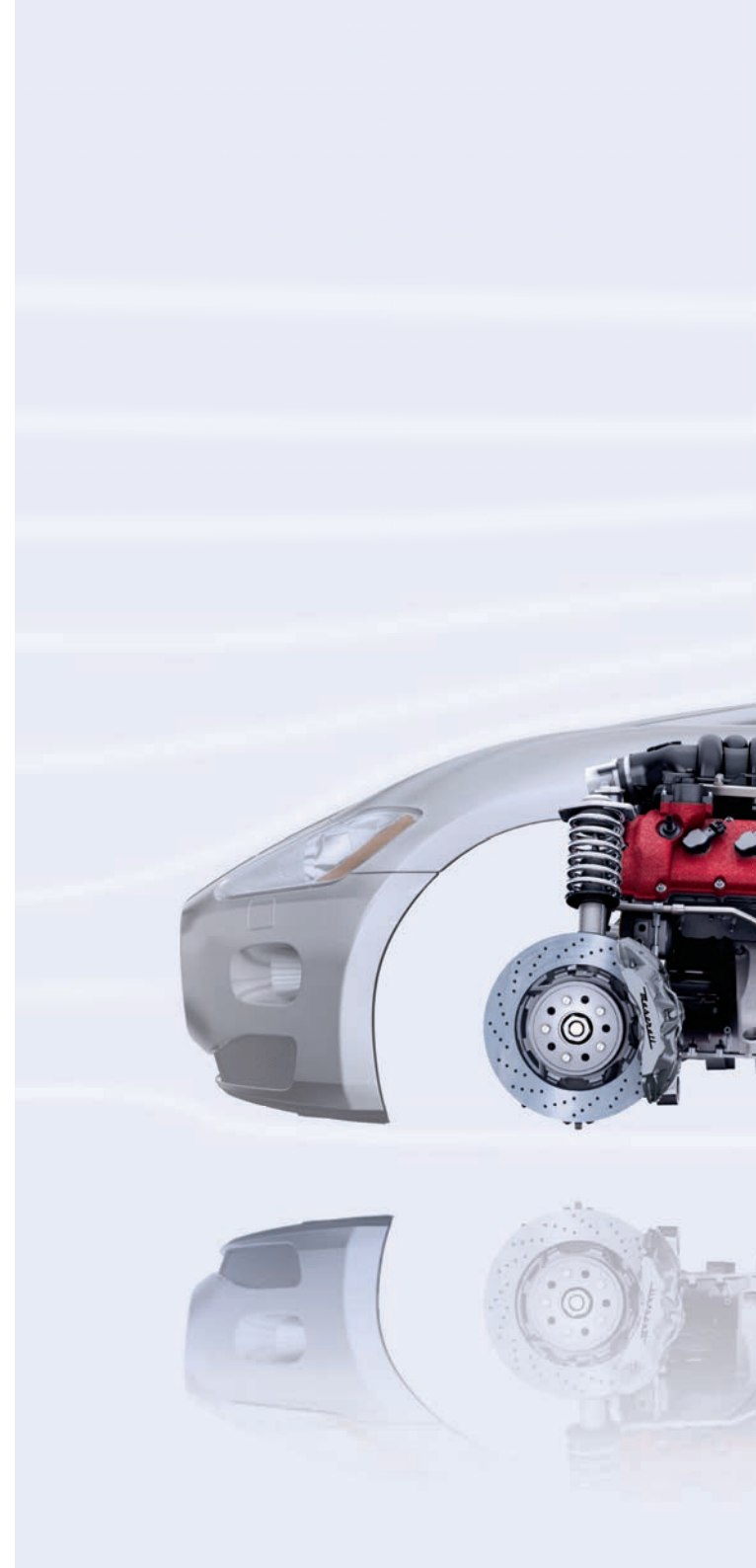

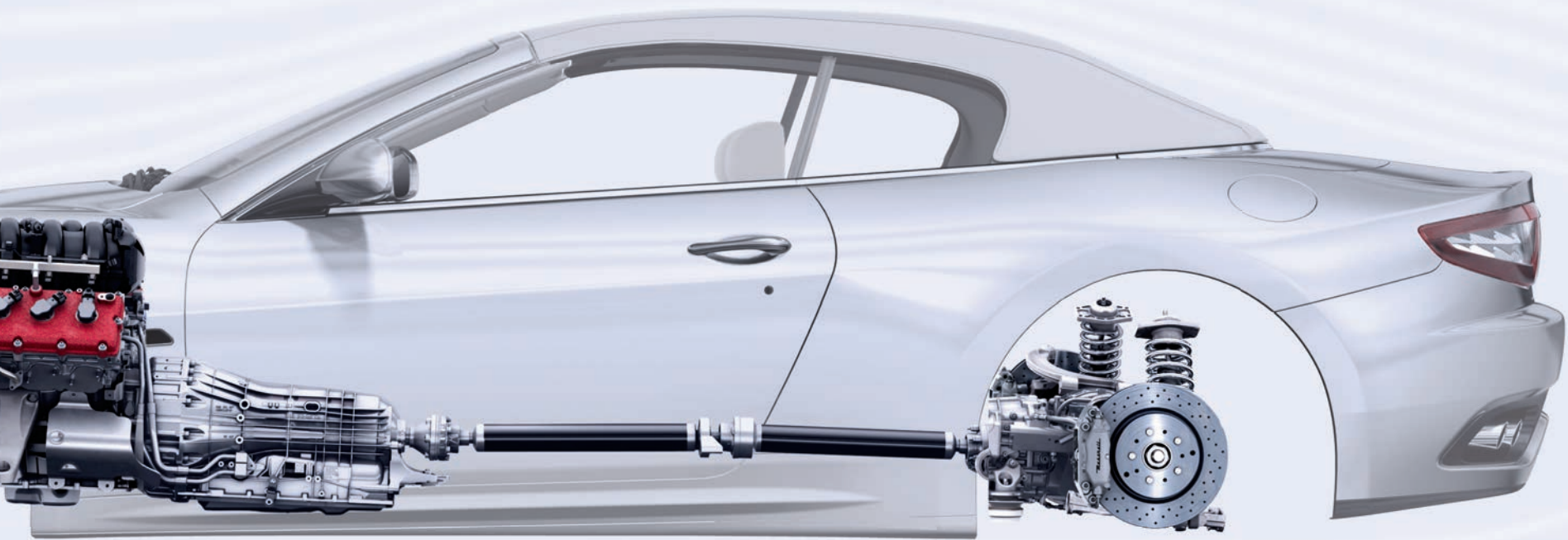

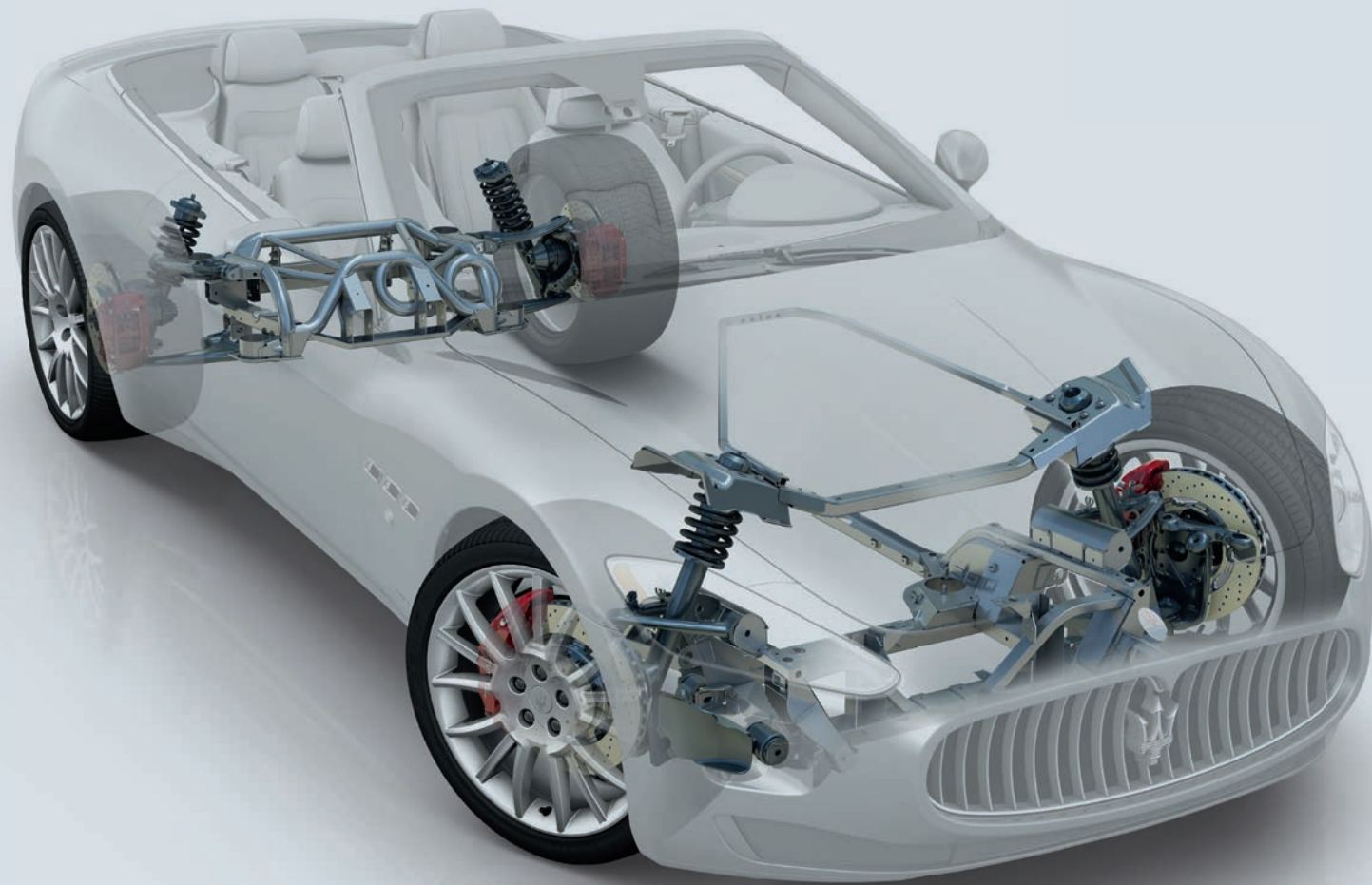

CHASSIS

The GranCabrio's chassis structure is made of steel, whilst the bonnet and front bumper reinforcement member is aluminium. The boot lid is constructed from a special thermoset plastic material which not only reduces the car's weight but is also more resistant to minor damage and corrosion.

The rigidity of the new chassis is extremely impressive: a dynamic torsional frequency of 27.2 Hz. Although 100 kg heavier than the GranTurismo coupé, the Maserati GranCabrio is every bit as exciting and pleasurable to drive.

SUSPENSION

The Maserati GranCabrio is equipped with aluminium gas dampers, and uses the Skyhook Continuous Damping System. This system "chooses" the optimum damping settings for the prevailing road and driving conditions, thus soaking up any bumps or jolts and ensuring the highest levels of ride comfort.

The Skyhook system employs acceleration sensors that detect the movements of each wheel and also the car body; the ECU then analyses this information and immediately adjusts the damper settings accordingly.

The driver can alter the car's handling characteristics by selecting one of two presets: Normal and Sport. The first mode provides relatively soft damping for a more comfortable ride; the second is more rigid, with reduced roll and load transfer.

The dynamic performance of the GranCabrio is also assisted by the Maserati Stability Programme (MSP), which has been specially developed by Maserati to optimise driving dynamics and safety. The system comprises a set of sensors that can detect any deviations from the car's ideal trajectory and then act on the brakes and engine to stabilise the car and correct any oversteer or understeer.



BRAKING SYSTEM

The Maserati GranCabrio is equipped with a high performance braking system employing dual-cast technology for the front brakes, a system developed in collaboration with Brembo. Each disc's external braking surface is made of cast iron, whilst the hub is aluminium; the monobloc brake callipers, also in aluminium, are more resistant to deformation than traditional two-piece callipers. The braking system has two circuits, with four ventilated and perforated discs. The front brakes comprise monobloc aluminium callipers with six pistons of different diameters and dual-cast discs measuring 360 x 32 mm, whilst the rear ones feature aluminium callipers with four pistons of different diameters and 330 x 28 mm discs. EBD is an integral part of the ABS system, for optimum braking force distribution between the front and rear wheels. To facilitate uphill starts, the car employs the Hill Holder system, which keeps the brakes on for a few seconds after the brake pedal is released on uphill slopes, thus enabling the driver's foot to shift over to the accelerator pedal without the vehicle moving backwards.

The GranCabrio is equipped with an electronic parking brake, which is engaged by an electric control on the central tunnel. The car also features HBA (Hydraulic Brake Assist) – a system that recognises panic braking and then, irrespective of the driver's foot pressure, applies the brakes with full force to minimise the stopping distance.







AWESOME POWER

At the heart of the GranCabrio lies Maserati's glorious 4.7 litre V8, with a power delivery of 440 hp at 7000 rpm, and a maximum torque of 490 Nm at 4750 rpm. The engine is configured at 90°, with timing handled by two chain-driven overhead camshafts per bank and four valves per cylinder controlled by hydraulic tappets. The camshafts on the intake side are fitted with a low pressure continuous phase timing variator, with valve actuation times of less than 0.15 seconds. The single timing chain makes the engine exceptionally reliable and quiet, with very low friction levels and consequently reduced fuel consumption. The precision timing also means excellent cylinder filling capacity, which in turn enhances the car's performance.

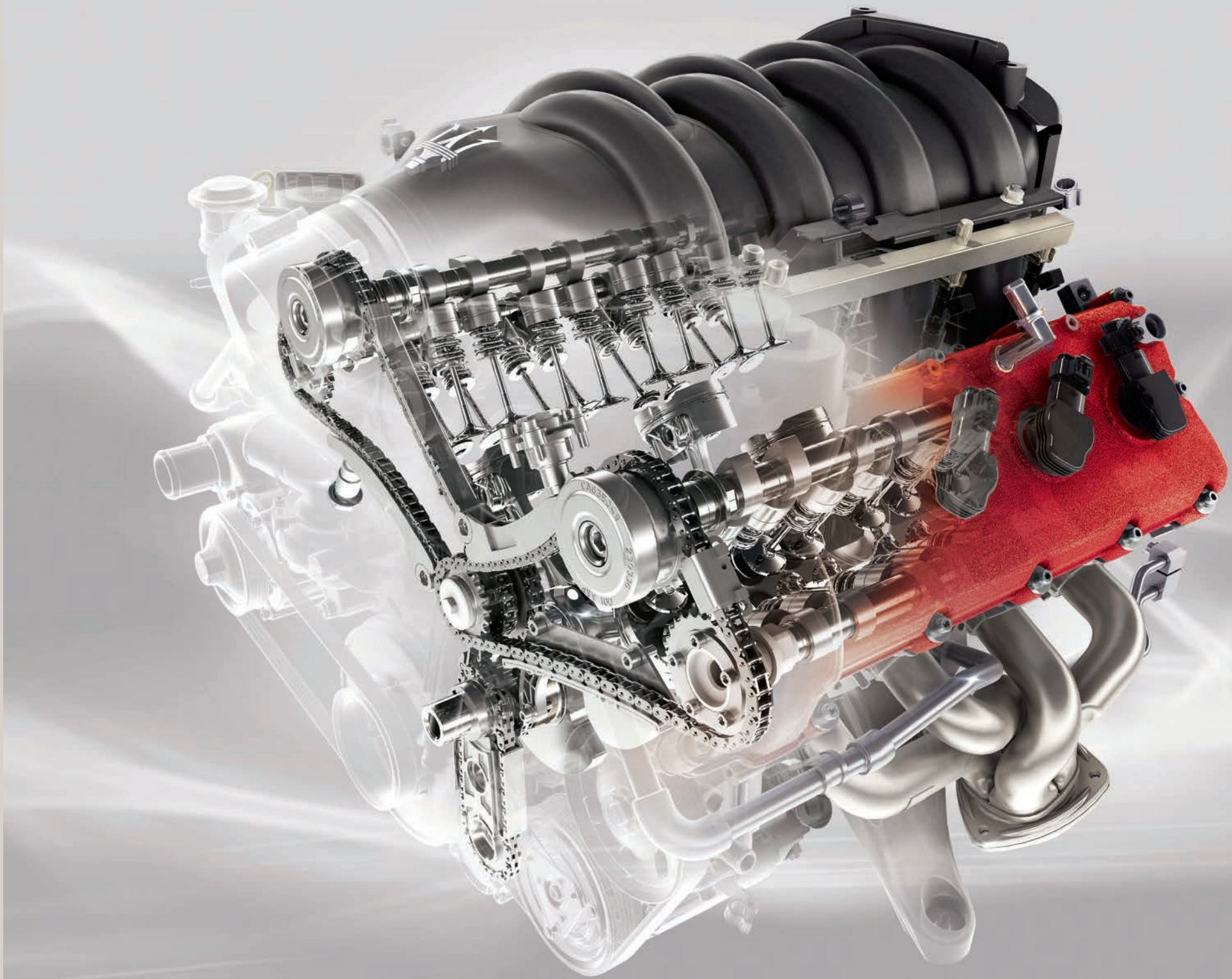

Wet sump lubrication is a feature of the 4.7 V8, the sump being integrated into the crankcase. The engine oil is circulated by a single immersed pump – a system that significantly reduces engine noise and consequently improves passenger comfort. 82% of torque is available from as low as 2500 rpm, delivering exceptional pick-up even in higher gears, so that overtaking is safer and driving in general is more enjoyable and sporty. Finally, the adoption of a metal matrix, perforated sheet catalytic converter delivers Euro 5 homologation without sacrificing performance.



PNEUMATIC EXHAUST BY-PASS VALVES

The Maserati GranCabrio's exhaust is controlled by pneumatic valves which, in Normal mode, are closed to ensure a low, discreet sound level. However, pressing the Sport button not only changes the car's performance and handling dynamics but also opens the exhaust valves, thus enabling the engine to deliver maximum power with a stirring roar – which is even more thrilling to hear with the top down.

The by-pass is controlled by a governor so that it only opens at over 3000 rpm. This gives the car two distinct characters: discrete and modest at low engine speeds, and responsive and powerful at high revs for an unforgettable driving experience.

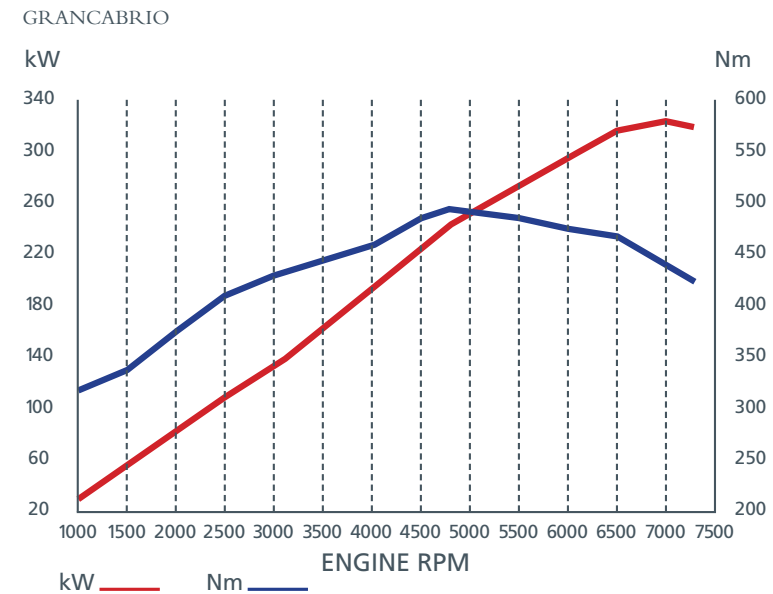



AUTOMATIC TRANSMISSION WITH HYDRAULIC TORQUE CONVERTER

The Maserati GranCabrio matches a ZF 6 speed automatic gearbox to its 4.7 litre engine – a combination which will impress the most demanding drivers with its acceleration, whilst still delivering smooth and fluid gearchanges for the comfort of all onboard.

The new hydraulic transmission enhances the performance of the Maserati V8 engine, especially at low and medium revs, without affecting performance at the higher end. Changing gear in Manual-Sport mode is very much in the super-fast sports car tradition.

The driver can choose from four different gearchanging modes:

AUTO NORMAL MODE

When driving normally, the shifting patterns are configured for maximum ride comfort. Upshifts occur as early as possible to achieve the lowest levels of vibration and engine noise, and to minimise fuel consumption. Gearchanges are smooth and almost unnoticeable.

When the driving style is recognised as being more sporty, gearshifts automatically take place at higher engine speeds, reducing the number of changes and resulting in higher performance.

AUTO SPORT MODE

In a normal driving, without heavy acceleration, the transmission drops down a gear compared to Auto Normal mode, making driving more engaging and producing a louder, more resonant engine noise.

When driving in this more sporty way, gearchanges occur at much higher engine speeds, whilst downshifting due to braking is calibrated to happen just before a bend in order to provide optimal control when entering it and then delivering the maximum power when exiting it.

This is the ideal set-up for challenging roads and more dynamic driving.

AUTO ICE MODE

When the driver activates the ICE mode, Sport mode is automatically deactivated (if it was on) and the stability control system (MSP) restored (if it was previously off); first gear is not engaged in order to reduce torque and prevent wheelspin, and gear changes take place at between 3000 and 4000 revs to optimise the car's traction.

MANUAL MODE

When the gearlever is shifted from D to the +/- position, gears are selected directly by the driver sequentially using either the gearshift lever or the paddles on the steering column. Using the gearshift lever, the driver changes gear in precisely the same way as a racing car: pulling the lever back changes up, while pushing it forwards changes down, which follows the motion of the body under acceleration and braking. The driver can at any time change from using the lever to the steering wheel paddles (by leaving the gearlever in the +/- slot). The steering wheel paddles adopted by Maserati differ from other systems used by its competitors due to their ergonomic positioning, i.e. attached to the steering column. This makes them immediately accessible at all times and, since they are in a fixed position, the driver always knows exactly where they are – an important safety feature in emergencies. Using the gearshift paddles also allows the driver to keep both hands on the wheel. Gearshifts are made with a simple flick of the fingers, which means extra safety on fast, winding roads, not to mention greater driving enjoyment.

In order to optimise driving safety and reliability, Manual mode includes automatic upshifts at the maximum permitted engine speed and automatic downshifts to prevent the engine from labouring. The exception is fifth gear, where the driver must make the change, both to maintain a sporty driving experience and to optimise performance.

The electronic kick-down can be activated at any time by flooring the accelerator in Auto mode. In Manual mode this function is disabled, as the driver uses the gearshift or paddles to select the appropriate gear.



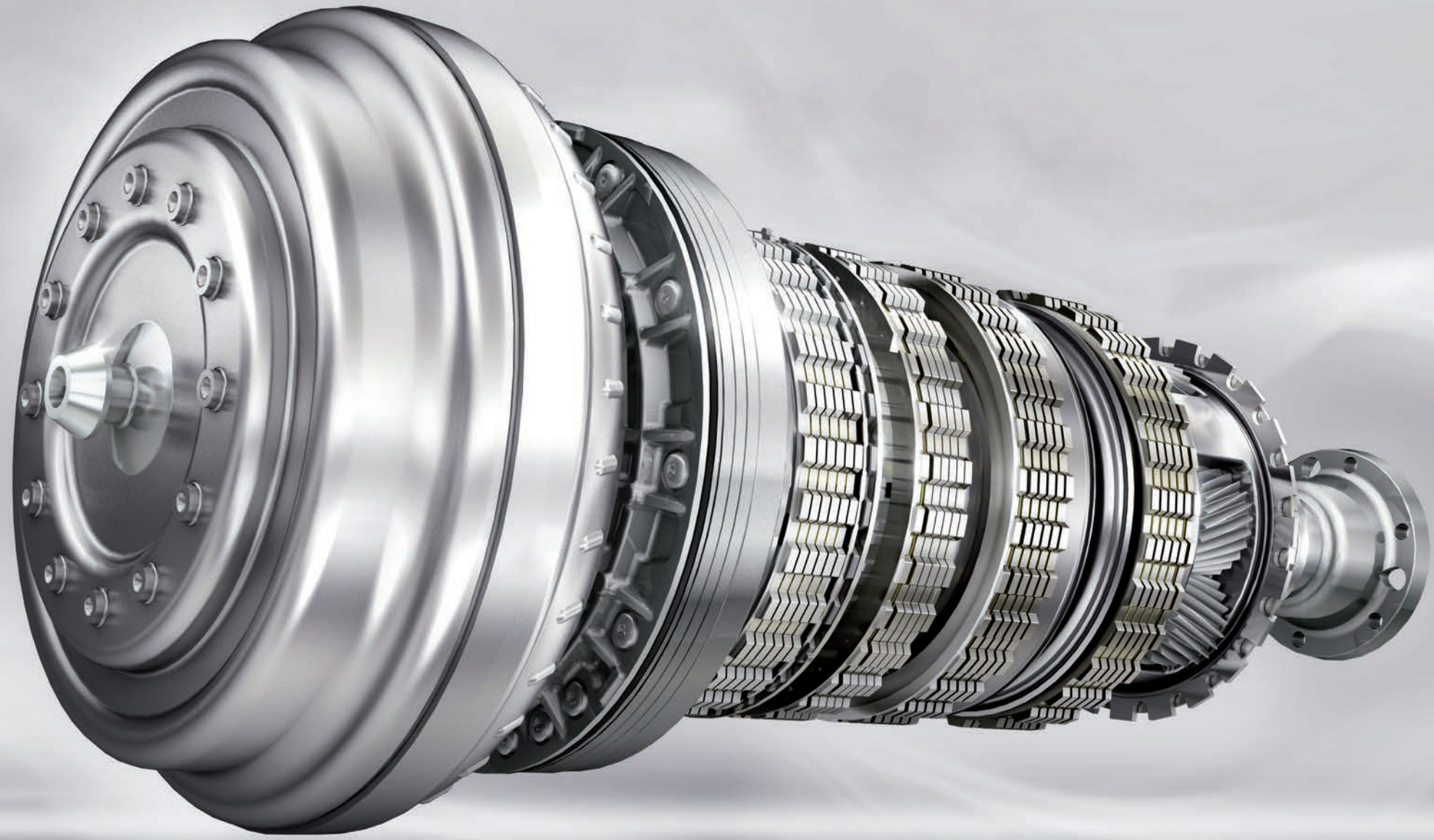

TRANSMISSION AND STEERING

The hydraulic transmission is located at the front of the car and is integrated with the engine. The driveshaft is articulated into two sections, transmitting the drive to the wheels through a self-locking differential.

Steering responsiveness and precision are also important aspects of a dynamic driving experience, as well as being vital to comfort and safety. The electronic servo-system ensures that the power steering action is always proportionate to the car's speed, so that there is always the right amount of 'feel' when driving at high speeds, yet light and precise steering when manoeuvring in tight spaces – which is made even easier in the GranCabrio, thanks to a turning circle of just 10.7 metres.

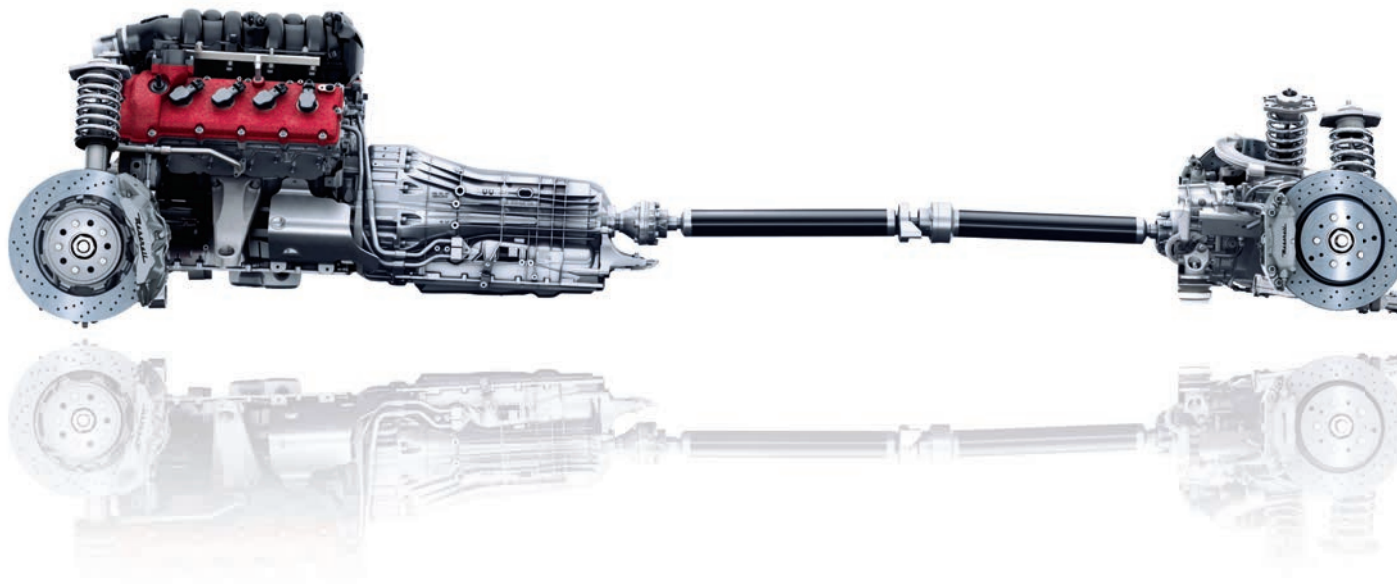

THE MASERATI GRANCABRIO SPORT

ELEVATE THE EXPERIENCE

THE NEW GRANCABRIO SPORT IS THE NATURAL EVOLUTION OF THE HIGH-PERFORMANCE GRANCABRIO. IT IS A CAR THAT EXPANDS HORIZONS AND BRINGS NEW LEVELS OF DRIVING PLEASURE TO THOSE ENTHUSIASTS WHO RELISH THE ULTIMATE IN PERFORMANCE AND THE THRILL OF WIND-IN-THE-HAIR MOTORING.

MASERATI GRAN CABRIO SPORT
ELEVATE THE EXPERIENCE



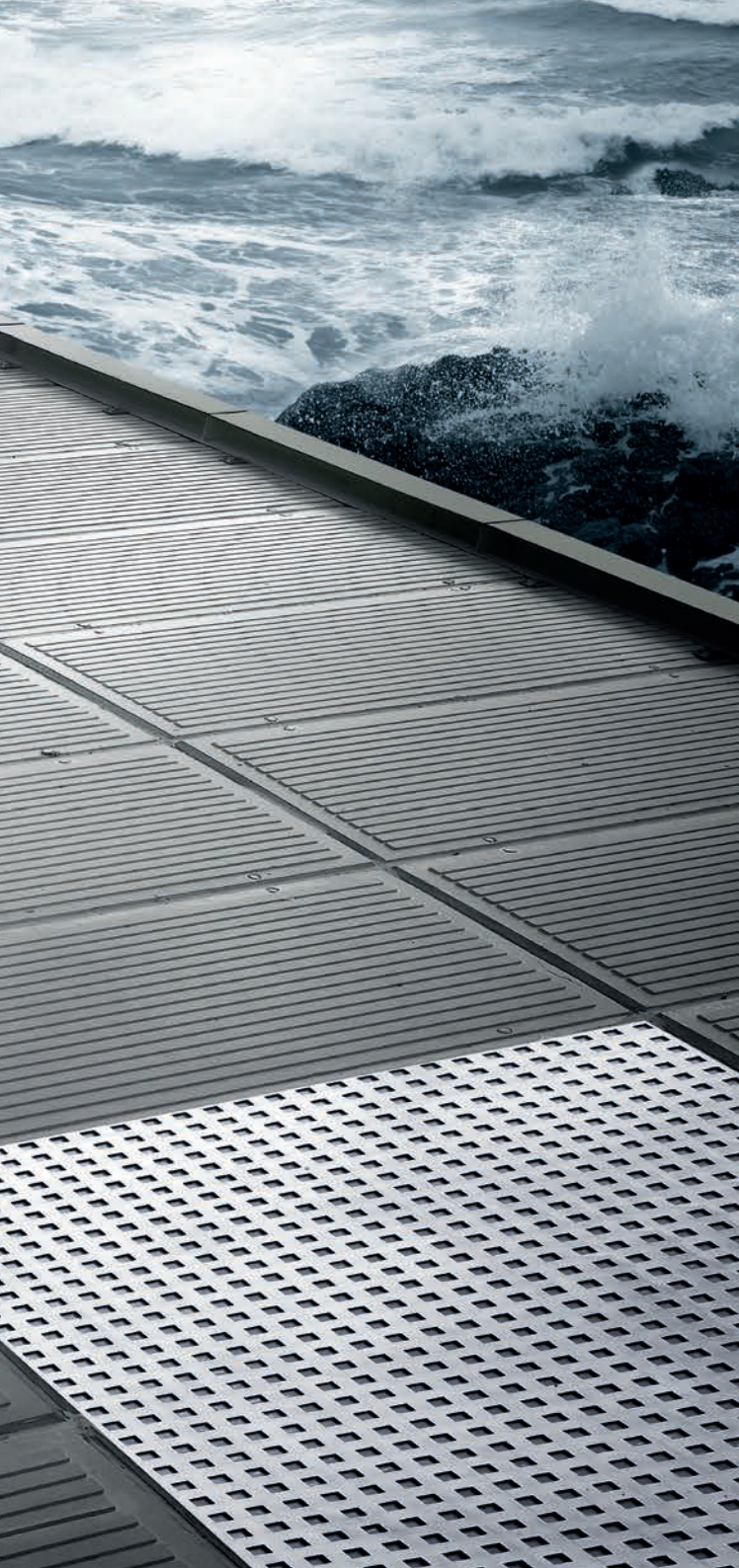

PASSION IN A SOPHISTICATED GUISE

Designed to deliver the ultimate in power and speed, the new Maserati GranCabrio Sport is available in a colour that defines its exuberant personality: Rosso Trionfale, inspired by the colour used on the Maserati racing cars in the 1950s. The most noticeable of its special styling features is the dynamic, distinctive design of the front. The famous Maserati radiator grille carries black vertical slats and a Trident badge with red highlights in the centre - the stylish touch that's shared by all Maserati's most powerful models. The headlights then have an internal black surround, with white detailing at the sides.



The front winglets have a new design and, like the door handles and rear-view mirror casings, are coloured to match the car's body. These items are also in carbon fibre through the MC Sport Line options. The body-coloured side skirts not only emphasise the car's aggressive character, but also make an important contribution to the vehicle's aerodynamics by channelling the air-flow to the rear wheels in the most efficient way. The side skirts can be supplied in black upon request. A black finish is also used along the shadow line around the windows, accentuating the car's dynamic image, and again on the tailpipes, which give a racing look to the rear end. Oval in shape, they make the new GranCabrio Sport highly distinctive, whilst through the MC Sport Line options they are available in carbon fibre.

20" Astro wheels have been specially designed for the GranCabrio Sport and come in two colours: Silver and Anthracite Grey, the latter with a very unusual metal-effect finish. Embellished with large tridents, they further underline the car's aggressive demeanour.





COMFORT FOR FOUR

The GranCabrio Sport exerts a charm that is truly hypnotic – the enticing invitation to take the wheel soon becomes truly irresistible. Excitingly aggressive yet with all the comfort and space expected of a car in its class, the GranCabrio Sport is uniquely tempting. To see it is to desire it.

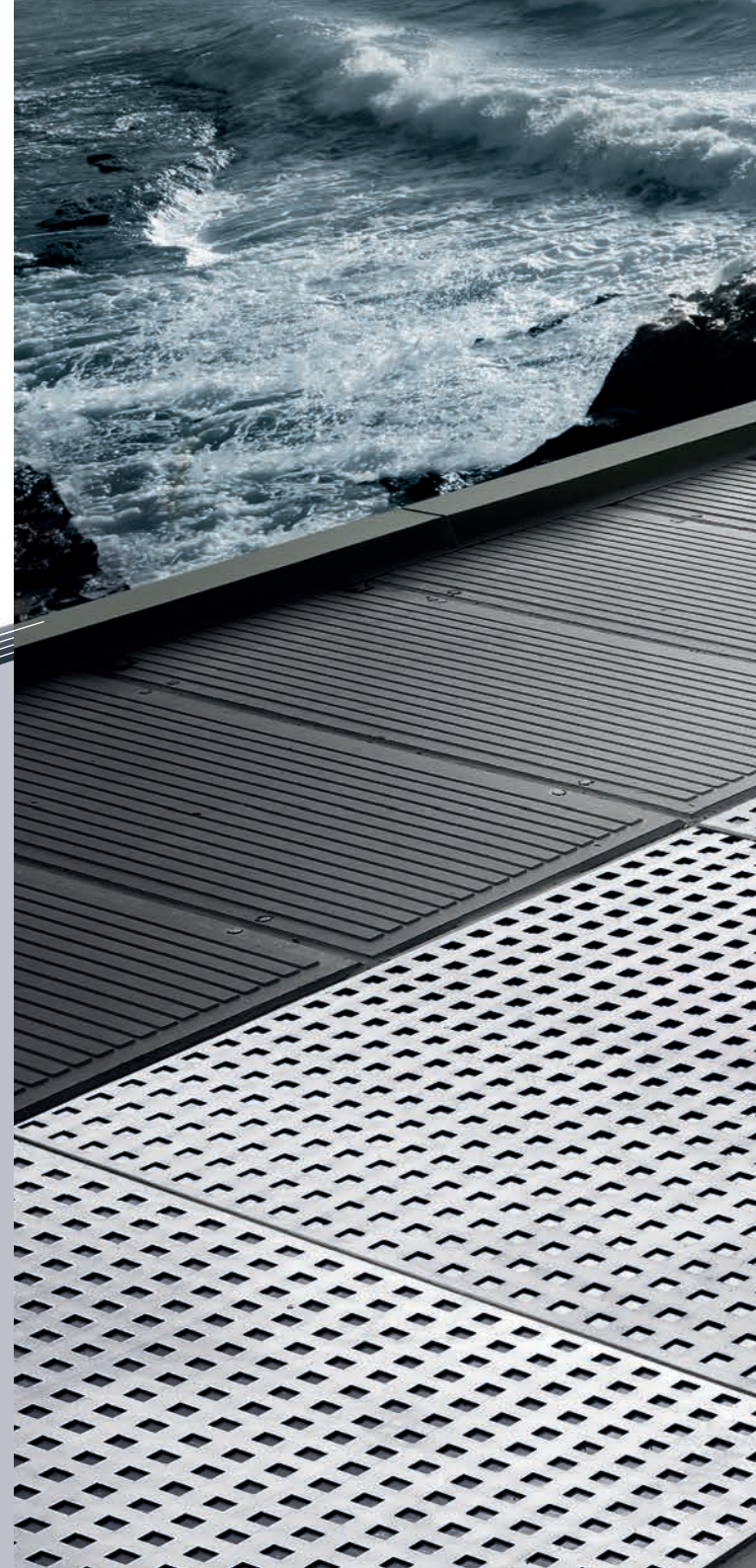



MASERATI GRAN CABRIO SPORT
ELEVATE THE EXPERIENCE



FRONT SEATS

The all-electric front seats come with lumbar support adjustment and can be specified with the optional comfort package. This includes seat position memories, heating with three temperature settings, and an easy entry/exit system which automatically raises or lowers the steering column when the door is opened, enabling the driver to get in and out of the car more easily. Certain details then make the GranCabrio Sport's interior even more exclusive. The new M-Design stitching in the centre of the seats resembles the Maserati radiator grille, whilst the soft Poltrona Frau® leather is available in two new colours, Bianco Pregiato and Grigio Chrono. The seats can also be personalised with the Trident logo stitched into the headrests in contrasting colours to the leather.

REAR SEATS

The GranCabrio Sport is a proper four seater that allows everyone on board to share the joys of open-top motoring. The individual contoured rear seats feature the same prestigious detailing as those at the front, and provide the perfect place for relaxation and ease. Once seated, the body settles into a comfortable, slightly reclined position that's ideal for the enjoyment high-speed motoring, even along fast, winding roads.





INTERIOR DETAILING

The GranCabrio Sport's interior surfaces help make the cabin even more sophisticated and refined. With the Dark Chrome finish, the interior acquires an aggressive look, whilst Glossy Black is perfect with the carbon fibre features. The wide range of carpets and mats has been extended with the new Grigio Chrono colour that matches up with the new Poltrona Frau® leather.

DRIVING PLEASURE

Standard on the GranCabrio Sport are two new features that underline its racing pedigree and enhance the driving experience. Firstly the leather steering wheel has Trofeo Design gearshift paddles that are longer than usual to ensure that they can easily be operated with the wheel at any angle. Then, in true racing style, the brake and accelerator pedals come in drilled aluminium.

INSTRUMENT PANEL AND DOOR SILL COVERS

The clear and concise instrument panel is identical to that of the GranCabrio, except for the addition of a digital rev counter that shows the best time to change gear.

The finishing touch to this exclusive environment is the brushed aluminium sill covers that sport the Maserati logo.



MC SPORT LINE CUSTOMISATION: A GRANCABRIO SPORT EXCLUSIVE

MC Sport Line customisation packages are designed to make the GranCabrio Sport even more sporty, dynamic, and individualistic. They include both styling kits and functional accessories that have been developed in competitive racing by the highly experienced Maserati Corse motorsport team.

Given the racing context, carbon fibre is used a lot in the products found in the MC Sport Line. On the exterior of the GranCabrio Sport, these include the front winglets, the door mirror casings, the door handles and the tailpipes. On the inside there are door sills with the MC Sport Line logo, the pedals and footrest, the gear shift paddles, the dashboard, the door panels and rear side panel mouldings, the central part of the dashboard, the instruments' housing, the steering-wheel rim and the gearshift control panel.

On the outside, the bonnet can be made even more striking with the V stripe livery, whilst aerodynamic fins in the rear bumpers emphasise the car's low-slung setup. Glossy black 20" Neptune wheels are then the ideal finishing touch for any GranCabrio Sport customised with MC Sport Line equipment.

TMC

Sport Line





STATE-OF-THE-ART TECHNOLOGY

The advanced, high-tech systems found on the GranCabrio Sport place the car at the very forefront of automotive engineering. Excitement, adrenalin and pure driving pleasure can be guaranteed, along with the highest standards of safety.

SKYHOOK SPORT SUSPENSION

Maseratis are renowned for their roadholding and handling, and these are two areas in which the GranCabrio Sport excels, thanks largely to its innovative suspension system. When the driver presses the 'Sport' button on the dashboard, the car's character is transformed as it switches to a more sporty set-up that has been specially developed to enhance its roadholding abilities. The dampers used in the Skyhook suspension have aluminium bodies and provide a constantly variable damping action. The system is controlled by an ECU that receives data from the acceleration sensors on each wheel and the chassis. It instantly processes the information and identifies the driving style, as well as the road surface conditions. The proportional valves installed in each of the dampers then allow the software to regulate their set-up in response to the prevailing conditions.

BRAKING SYSTEM

The GranCabrio Sport is equipped with a powerful braking system. The four ventilated discs are machined with four slots and sixteen blind holes around the perimeter, which reduce stopping distances and make the braking performance more constant in the long term. The slots help keep the brake pads clean and free from dust, and also break up the flow of water in the rain. Meanwhile the extra holes disperse the heat and ensure that the pads wear in a uniform manner.



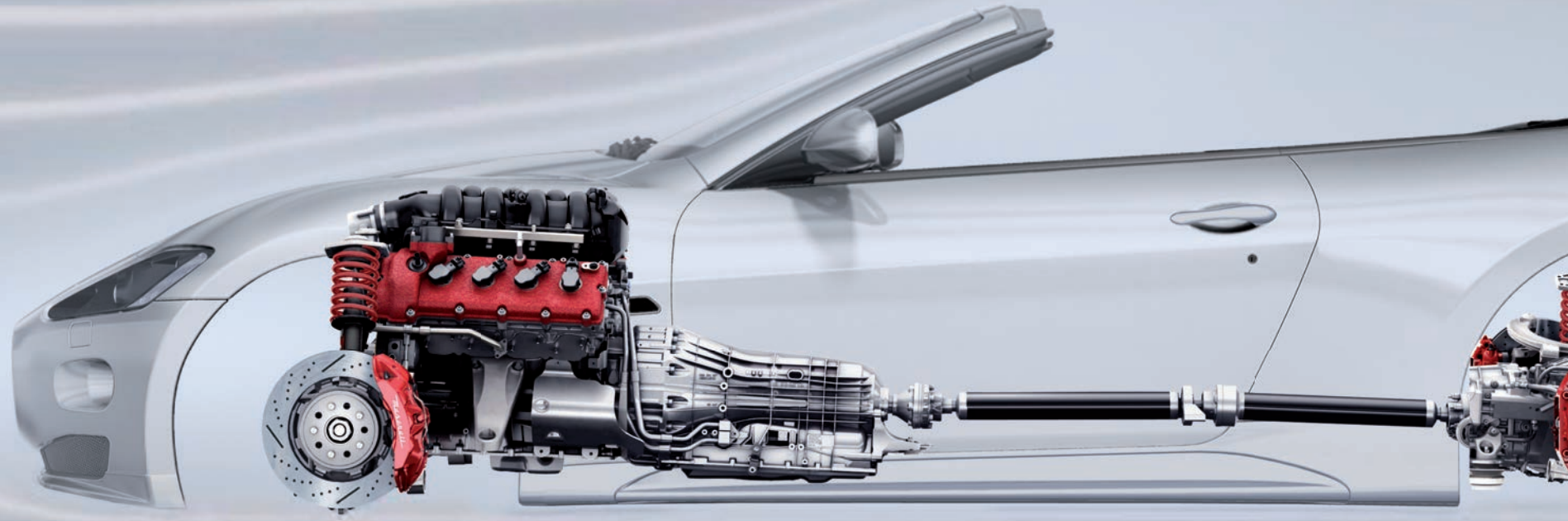



AERODYNAMIC EFFICIENCY

The aerodynamics and styling of the GranCabrio Sport have been developed in tandem to minimise the drag coefficient: just 0.35 with the roof up, and 0.39 with roof down – exceptional figures for an open top car. This was achieved in part thanks to the special structural reinforcement underneath the body, and the painstaking design of the hood, which does not impair the car's aerodynamic efficiency even at high speed.

CHASSIS

The supporting monocoque is made of galvanised steel with box-section panels. The bonnet and front bumper cross-member are in aluminium and the boot lid is formed from a thermoset composite material. The chassis exceeds the most severe international crash test standards: constructed in steel, it incorporates a tubular structure at the rear to support the suspension and differential, and a front section to support the V8 engine.

THE IRRESISTIBLE APPEAL OF HIGH PERFORMANCE

Under the bonnet of the GranCabrio Sport lies a mighty engine with prodigious power and a deep, sonorous note to match. The most powerful of Maserati's powerplants, this glorious 4.7 litre V8 delivers 450 hp at 7,000 rpm, and 510 Nm of torque at 4750 rpm, together with comparatively modest fuel consumption and exhaust emissions. The camshafts on the intake side are fitted with CVVT (Continuously Variable Valve Timing), and the single timing chain makes the engine exceptionally reliable and quiet. DLC (Diamond-Like Coating) and 'superfinishing' of the camshaft lobes mean very low friction levels, which in turn means improved efficiency overall.





MASERATI GRAN CABRIO SPORT
ELEVATE THE EXPERIENCE

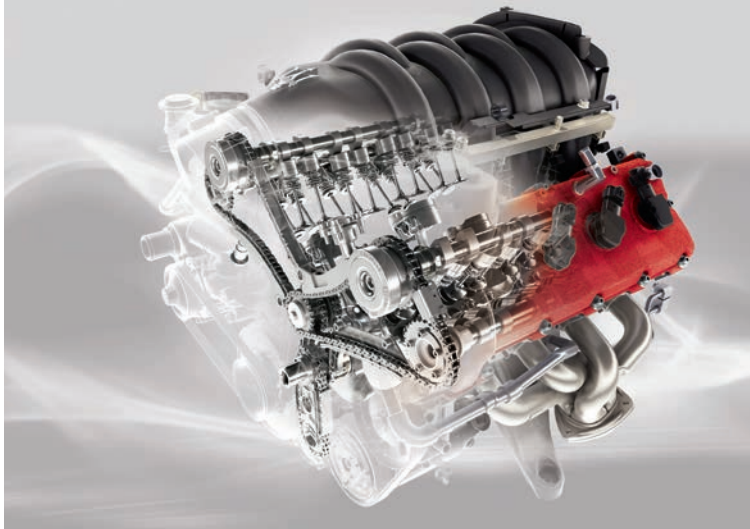

PNEUMATIC BYPASS VALVE SYSTEM

Thanks to the shape of the tailpipes and the pneumatic exhaust bypass valves, the GranCabrio Sport produces a rich, deep and throaty sound that is worthy of its race-bred heritage. In 'Normal' mode the valves are kept closed, forcing the exhaust gases to travel a long way before discharge. This means that when they finally leave the system, they have lost much of their energy and clamorous turbulence. However, at a touch on the 'Sport' button above 2,500 rpm, the valves are opened and the flow of gases is directed along a path that leads straight out into the exhaust pipes, thus generating that marvellous Maserati sound.

TRANSMISSION

The GranCabrio Sport inherits its six-speed transmission from the acclaimed Quattroporte Sport GT S. This gearbox offers a choice of five operating modes: Auto Normal, Auto Sport, Manual Normal, Manual Sport and Ice. Selecting Auto or Manual Sport mode activates the MC Auto Shift function and the highest possible performance: acceleration from 0 to 62 mph in just 5.2 seconds. The driver is provided with full information about the transmission on the display in the centre of the instrument panel, whilst for manual gearshifts the car has extra long 'Trofeo Design' paddles, which have been developed specifically for this model.

GRANCABRIO SPORT

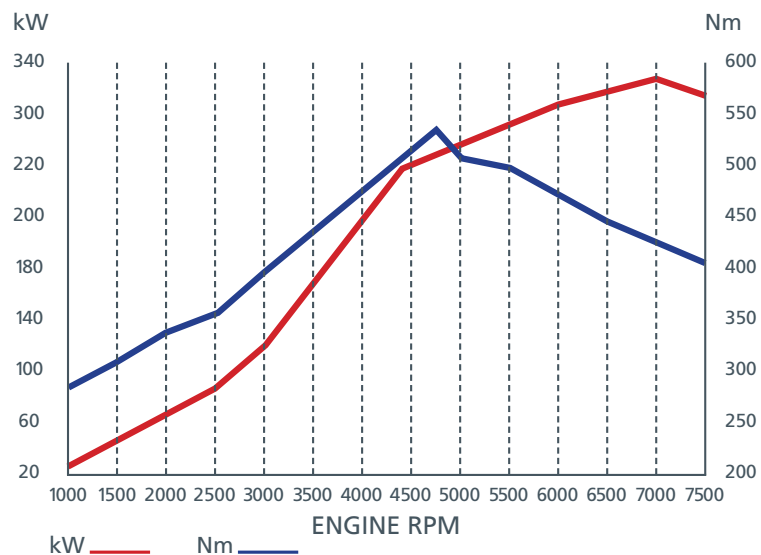

MC START STRATEGY

This function is activated in Auto Sport mode and when the MSP system is off. To use it, the driver simply holds the car on the footbrake, presses down on the accelerator pedal, and does not release the brake until the engine has reached around 2,300 - 2,500 rpm. This results in the car rocketing from 0-62 mph in just 5.2 seconds.

MC AUTO SHIFT

On the GranCabrio Sport, in Manual Sport mode, the MC Auto Shift function allows the driver to keep the car in a given gear right up to the point where the rev limiter cuts in. In Manual Normal mode, the driver controls gearshifts directly and changes take place up to the red line on the rev counter. Electronic heeling and toeing is possible for down-shifts in Manual Sport and Auto Sport modes - a capability that is much prized by more experienced and exuberant drivers.





MASERATI GRAN CABRIO SPORT
ELEVATE THE EXPERIENCE

MASERATI GRAN CABRIO RANGE

TWO PERSONALITIES, ONE SOUL

ONE MORE ELEGANT AND GRACEFUL, THE OTHER MORE SPORTY AND DYNAMIC: THE GRANCABRIO AND GRANCABRIO SPORT HAVE TWO VERY DIFFERENT PERSONALITIES. HOWEVER, WHAT THEY SHARE IS THE SAME MASERATI SOUL, WHICH MEANS IMMENSE POWER, UNCOMPROMISING PERFORMANCE, THE HIGHEST LEVELS OF COMFORT AND LUXURY AND, ABOVE ALL, RAW PASSION.

ACTIVE SAFETY

MASERATI STABILITY PROGRAMME (MSP)

If the car begins to oversteer or understeer, the Maserati Stability Programme (MSP) is on hand to correct the situation. It does this by reducing torque from the engine and activating the brakes, stabilising the car within milliseconds. The ABS system prevents the wheels from locking while braking, allowing the driver to steer the car and maintain control. EBD then distributes the braking force optimally between the front and rear axles. When the Sport mode button is pressed, the action of the MSP is altered to allow more sporty handling – but without compromising safety. The cut-in threshold is moved upwards and the system concentrates primarily on activating the brakes rather than reducing engine power. Given its enhanced power and handling potential, the GranCabrio Sport has updated MSP settings to maximise the thrilling driving experience. Note that MSP is not a failsafe device and will not prevent accidents in extreme circumstances; the ultimate safety of the car always rests with the driver.





MASERATI GRAN CABRIO SPORT
ELEVATE THE EXPERIENCE

PARKING SENSORS

The Maserati GranCabrio is equipped with rear parking sensors integrated into the rear bumper which, together with the optional front sensors, facilitate manoeuvring in restricted spaces. Along with an audible warning, the instrument panel shows the car surrounded by colour-coded symbols indicating the distances to nearby obstacles (green, yellow and red).

CRUISE CONTROL

The Cruise Control function automatically maintains a pre-set cruising speed, with no need for the driver's foot to be kept on the accelerator. When it is active, the gearshift patterns alter according to the gradient of the road – the changes then take place at intervals that are calibrated for maximum smoothness and comfort.

ADAPTIVE HEADLIGHTS

The highly effective Bi-Xenon headlights, which are fitted as standard, are enhanced by a rotation function that improves the illumination of the road and surrounding areas, and hence improves safety when driving at night on winding roads. The electronic high and low beam control unit continually monitors information relating to the angle of the front wheels and the car's speed, and then activates special electric motors to rotate the light cones. The system operates at speeds over 3 mph, and the rotation angle reduces between 56 mph and 75 mph. It then deactivates at speeds over 75 mph or when reversing, for reasons of safety.

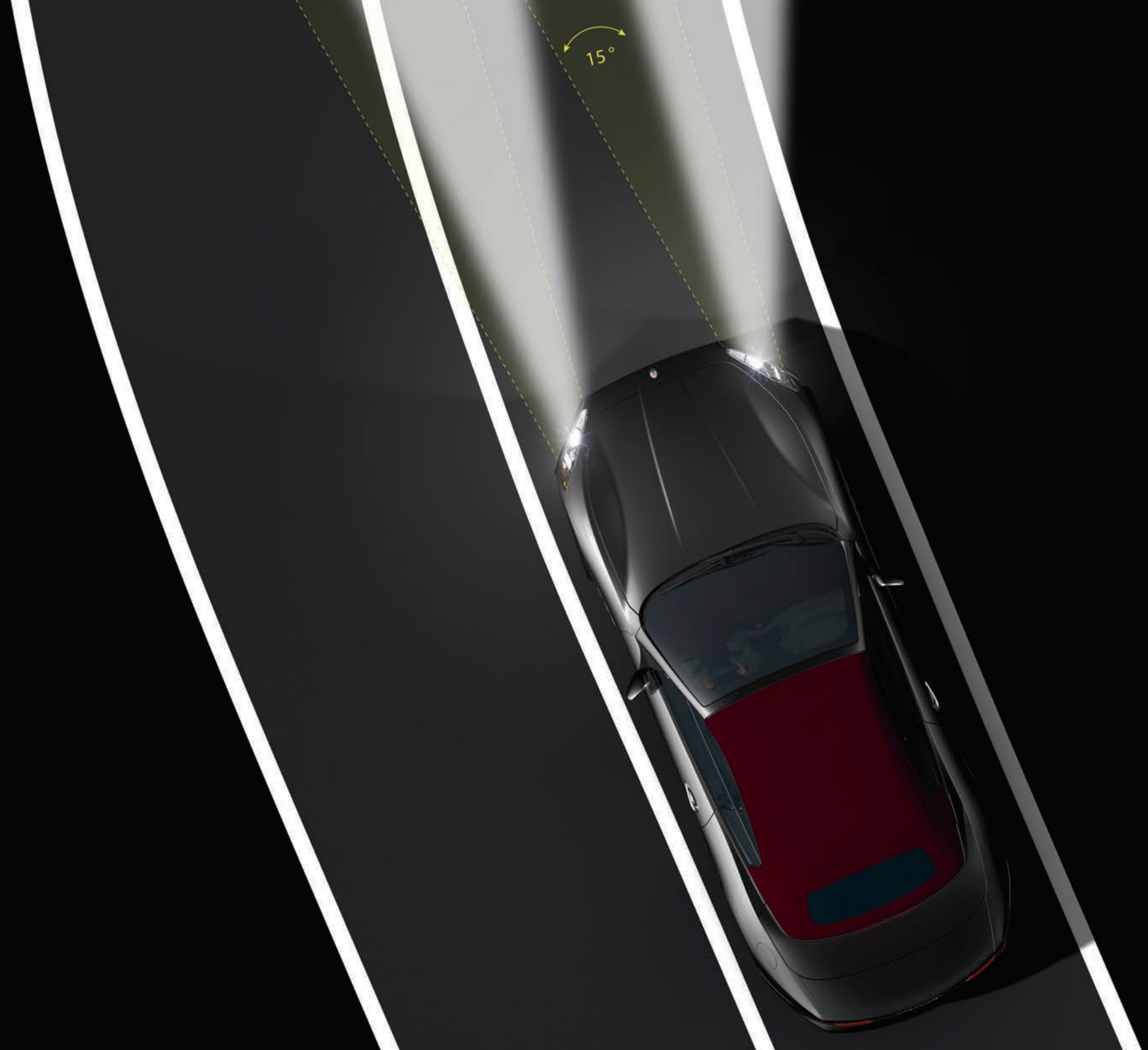



PASSIVE SAFETY

AIRBAGS

The Maserati GranCabrio range uses a new generation of dual stage airbags for the driver and front passenger. The latter is protected by airbags that adapt to size and stature. A multi-action system protects the chest and head not only from frontal collisions, but from lateral impacts too, with side airbags mounted in the seat backs.

ACTIVE ROLL-OVER BARS

A telescopic roll-over bar system is located behind the rear seats and remains out of sight, covered by the tonneau cover. Controlled by the airbag ECU, this is activated in under 190 milliseconds – less than the blink of an eye.

SEATBELTS WITH PRETENSIONERS

The front and rear seatbelts are electronically controlled and equipped with the latest pyrotechnic pretensioners and load limiters. The system communicates with a sensor that instantly evaluates the seriousness of a collision and inflates the airbags with the optimal amount of force – it even takes into account whether the seatbelts are fastened or not.

IMMOBILISER AND ANTI-THEFT SYSTEM

All GranCabrios are protected by an immobiliser that reacts to a transponder in the ignition key, as well as a system that comprises an anti-lift sensor and ultrasound volumetric sensor, perimeter protection and an alarm located in the engine compartment. The remote control has three functions: doors lock/unlock and boot release.





MASERATI GRAN CABRIO SPORT
ELEVATE THE EXPERIENCE

CUSTOM OPTIONS

The interior of the GranCabrio range is upholstered in the finest leather from Poltrona Frau®, a company long renowned for the quality of its hides and its traditional processing techniques. The Poltrona Frau® leather used for the GranCabrio goes through a rigorous selection process that rejects all but the softest, most tactile, and best quality hides. The treatments they then undergo add durability, strength, and practicality to their attractive appearance, whilst hand finishing processes ensure that the leather is soft and snug in winter, yet cool and comfortable in the summer. These help give it that very special feature that makes 'ageing' a factor that actually enhances the leather's appeal - like a great vintage wine.

The leathers are available in ten colours, giving free rein to your creativity. The colours of the seats, dashboard, tonneau cover, cross beam, steering wheel and gear lever knob can all be co-ordinated with those of the stitching, carpets and interior fabric of the soft top. Areas of the dashboard, door panels and rear side panels are other places that can be personalised: Dark Chrome Grey is the standard finish, but exotic woods are also available, evoking the warm and elegant charm of an Italian classic car. In addition there are lacquered colour finishes for a more sporting, exclusive appearance.

EXOTIC WOODS AND HIGH QUALITY MATERIALS

Maserati owners are well aware of how much care is taken in selecting the right materials to make their car's interior both elegant and luxurious. Carbalho wood and Moonwood are just two examples of the extensive range of veneers. Carbalho, with its characteristic veining, is a very special wood from Brazil (Carvalho Brasileiro). Thanks to a three-dimensional effect it produces, a different veining pattern occurs in every piece of wood. It is this unique and highly prized characteristic that gives each car its own special signature - even the next GranCabrio off the production line will have a different pattern of Carbalho wood. Moonwood, on the other hand, is an engineered, multi-layered wood. In a light colour with a pinkish grain, it suits the interior of the car admirably.

The Maserati GranCabrio also offers a new standard colour for the climate control system and Maserati Multi Media System screen surrounds: Dark Chrome Grey, a warm yet sporty tone that combines anthracite grey with appealing highlights. It is the fine details of a car like this that make all the difference. This is why the carpets can be customised with no less than seven different coloured borders: black, blue, Bordeaux, grey, brown, red and sand. Rest assured that no-one else will ever have a GranCabrio exactly like yours.



MASERATI GRAN CABRIO SPORT
ELEVATE THE EXPERIENCE





COMFORT

THE SOFT TOP

Both the GranCabrio and GranCabrio Sport feature a highly sophisticated, electrically operated soft top which is available in a range of colours that allow for a vast number of roof and bodywork combinations. The roof's frame is composed of five steel and aluminium spokes that support the high quality fabric. It also has an integrated thermal glass rear window that makes the car as pleasurable to drive in winter as it is in summer. Weighing a mere 65 kgs, it has a minimal effect on the car's dynamics.

For the ultimate in durability and reliability, the soft top system has been subjected to numerous, extremely stringent tests in some of the most remote and challenging areas of the world – consequently the canopy is made from a triple-layer fabric. This is available in six external colours: black, blue, and Burgundy (an elegant maroon), chocolate, titanium grey and Java (classic beige). Three colours are available for the interior of the canopy: black, beige and Beluga grey. The soft top is totally rain and weather-proof, and offers excellent soundproofing when up.

On the hottest days of the year, getting into the car is made more bearable by means of its ‘Summer Opening’ system. When the key is inserted into the driver’s door lock and turned clockwise for more than two seconds, the top starts to rise and fold away – in just 28 seconds. This means that the top is already down when you get into the car, and the heat inside has been released. The same system can be used to close the top – by turning the key counter-clockwise.

Should you encounter a sudden shower whilst driving with the top down, there is no need to stop. Just slow to 18 mph or below and hold the ‘Close’ button down for a few seconds: the roof then closes, and you and your passengers are protected from the rain and wind.







WINDSTOP

When driving alone or with just one passenger and the roof down, both GranCabrios can be enjoyed even more with the windstop in place – a device that has been specially developed for the cars. The windstop, a product of wind tunnel testing, reduces the amount of air entering the compartment, thus minimising the usual amount of noise and buffeting. The windstop decreases the air flow from the rear by 70%, whilst the air speed inside the compartment is reduced by 50%. When the car has four occupants, the windstop can be stored in its special bag which stows away in the luggage compartment.

CLIMATE CONTROL SYSTEM

The automatic dual-zone climate control system maintains ideal conditions inside the cabin when the top is up by automatically and discretely adjusting the temperature and the intensity of the ventilation in relation to the outdoor temperature, sunlight intensity and air humidity. The fully electronic unit allows the driver and passenger to set their own preferred temperature separately, between a minimum of 16°C and a maximum of 32°C. Two vents on the central tunnel behind the front seats then direct the air to those in the rear, maintaining the ideal climate there, too.



BOSE® SURROUND SOUND SYSTEM

With twelve high quality speakers perfectly integrated into the GranCabrio and GranCabrio Sport, Maserati's development team and acoustic engineers from Bose® have created a sound system capable of satisfying even the most demanding audiophiles. The woofers (low frequency loudspeakers) are both powerful and precise, whilst the higher frequencies, which are generally most compromised in a moving car, are crystal clear thanks to the superior mid-range and tweeter speakers. A highly effective AudioPilot system maintains the volume and sound quality by automatically compensating for changes in the engine's note, the noise transmitted from the tarmac, and even the challenges of top-down driving conditions. With the Bose® Surround Sound System, both GranCabrios can deliver the kind of acoustics usually experienced in a concert hall.

ADDITIONAL EQUIPMENT

The GranCabrio and GranCabrio Sport can be specified with a wide range of optional high-tech equipment that is designed to make driving safer and even more enjoyable.

- Electrically-operated, electrochromic door mirrors: these darken progressively as the intensity of the light from behind increases, thus preventing dazzling (this is standard on the interior rearview mirror).
- Garage remote control: this allows the frequencies of up to three remote controls to be transferred directly to the car's onboard system, which is located on the driver's sun visor.
- Tyre Pressure Monitoring Sensors (TPMS): these continually monitor tyre pressures while driving. The system displays the individual tyre pressures on the information panel and alerts the driver if they fall below the minimum levels - or in the event of a puncture.





LUGGAGE

Journeying in a GranCabrio or GranCabrio Sport can be further enhanced with a set of bespoke luggage, available in leather and leather/fabric combinations. The basic set comprises a man's wheeled suitcase, a woman's wheeled suitcase, a man's accessories case and a woman's beauty case. There is also a suitcase that is designed to be loaded onto the rear seats and held in place by straps.

ASHTRAY

To optimise the space available in the car, the ashtray fits into one of the four cup-holders provided. The ashtray has a finely crafted aluminium body with a shiny rim to match the chrome finish on the surrounding controls.



BODYWORK

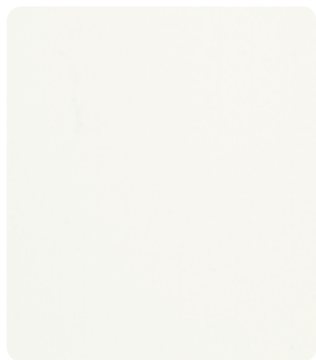

Bianco Eldorado



Grigio Touring



Grigio Alfieri



Grigio Granito



Rosso Trionfale

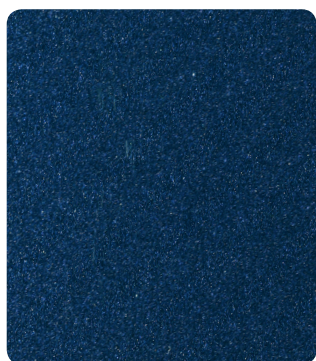

Blu Nettuno

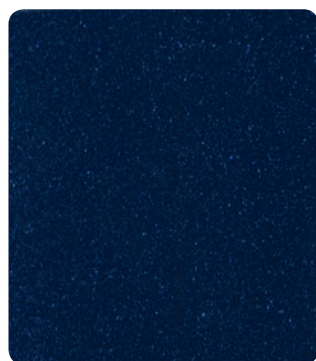

Blu Oceano

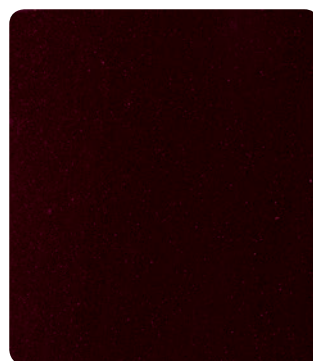

Bordeaux Pontevecchio

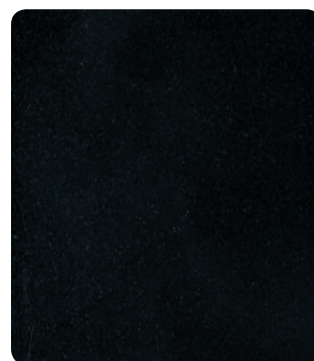

Nero Carbonio



Nero

PAINT COLOURS

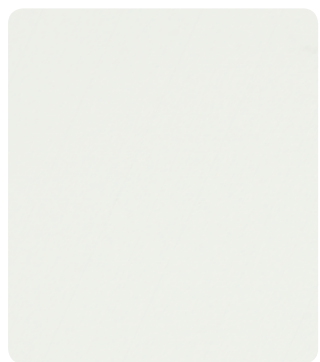

Bianco Fuji



Giallo Granturismo



Blu Mediterraneo

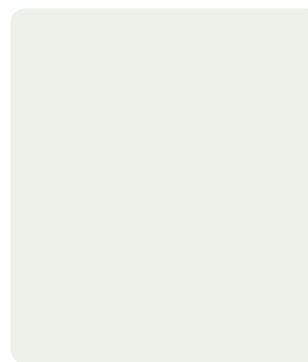

Bianco Fuji



Blu Mediterraneo



Rosso Mondiale



Grigio Nuvolari



Argento Luna



Grigio Granito

SPECIAL PAINT

MATT COLOURS

INTERIOR



Pearl Beige

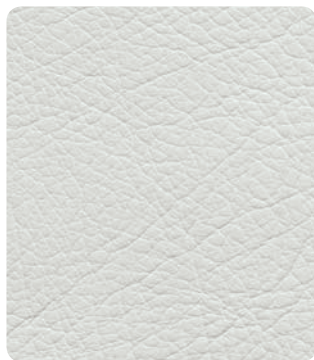

Bianco Pregiato



Sabbia



Cuoio



Marrone Corniola



Grigio Chrono



Blu Profondità



Rosso Corallo



Bordeaux

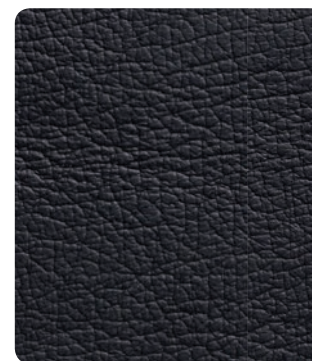

Nero

LEATHER COLOURS



Rosewood

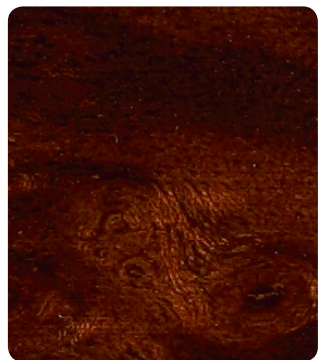

Walnut Briarwood

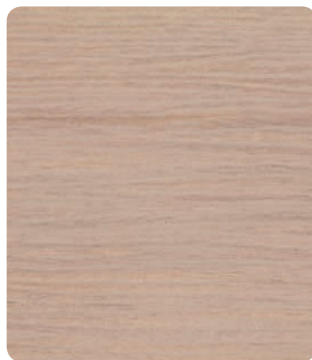

Moonwood



Blu Laque



Black Piano



Wengè Polished



Carbalho

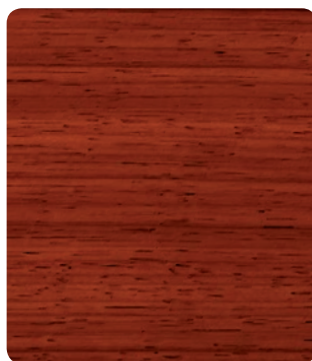

Padouk



Dark Chrome



Glossy Black

INTERIOR WOOD TRIM

INTERIOR FINISHES

SOFT TOP



Nero



Beige



Java

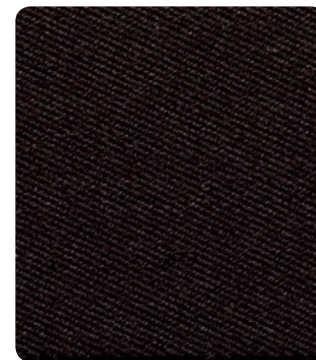

Cioccolato

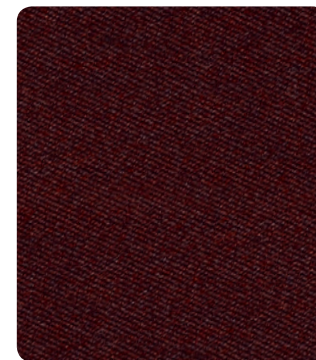

Burgundy



Grigio Beluga

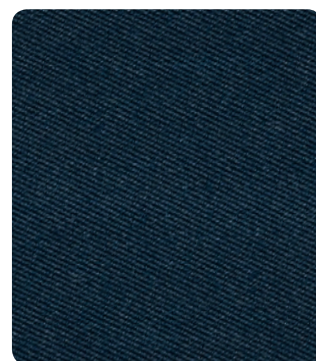

Blu

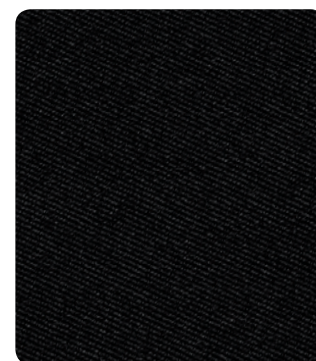

Nero



Grigio Titanio

INTERNAL HEADLINING

EXTERNAL COATING



GRANCABRIO – WHEELS



Alloy wheels
Birdcage design
Silver
(8,5J x 20" front; 10,5J x 20" rear)



Alloy wheels
Birdcage design
Grigio Mercury
(8,5J x 20" front; 10,5J x 20" rear)



Alloy wheels
Trident design
Silver
(8,5J x 20" front; 10,5J x 20" rear)



Alloy wheels
Trident design
Grigio Mercury
(8,5J x 20" front; 10,5J x 20" rear)



Alloy wheels
Neptune design
Silver
(8,5J x 20" front; 10,5J x 20" rear)



Alloy wheels
Neptune design
Grigio Mercury
(8,5J x 20" front; 10,5J x 20" rear)

GRANCABRIO – BRAKE CALLIPERS



Brake callipers GranCabrio
painted Nero
Drilled brake discs



Brake callipers GranCabrio
painted Argento
Drilled brake discs



Brake callipers GranCabrio
painted Rosso
Drilled brake discs



Brake callipers GranCabrio
painted Blu
Drilled brake discs



Brake callipers GranCabrio
painted Giallo
Drilled brake discs



Brake callipers GranCabrio
painted Titanio
Drilled brake discs



Brake callipers GranCabrio
painted Rosso Opaco
Drilled brake discs

GRANCABRIO SPORT – WHEELS



Alloy wheels
Birdcage design
Silver
(8,5J x 20" front; 10,5J x 20" rear)



Alloy wheels
Birdcage design
Grigio Mercury
(8,5J x 20" front; 10,5J x 20" rear)



Alloy wheels
Trident design
Silver
(8,5J x 20" front; 10,5J x 20" rear)



Alloy wheels
Trident design
Grigio Mercury
(8,5J x 20" front; 10,5J x 20" rear)



Alloy wheels
Neptune design
Silver
(8,5J x 20" front; 10,5J x 20" rear)



Alloy wheels
Neptune design
Grigio Mercury
(8,5J x 20" front; 10,5J x 20" rear)



Alloy wheels
Neptune design
Nero
(8,5J x 20" front; 10,5J x 20" rear)



Alloy wheels
Astro Design
Silver
(8,5J x 20" front; 10,5J x 20" rear)



Alloy wheels
Astro Design
Silver Shiny Antracite Grey
(8,5J x 20" front; 10,5J x 20" rear)

GRANCABRIO SPORT – BRAKE CALLIPERS



Brake callipers GranCabrio Sport
painted Nero
Drilled and slotted brake discs



Brake callipers GranCabrio Sport
painted Argento
Drilled and slotted brake discs



Brake callipers GranCabrio Sport
painted Rosso
Drilled and slotted brake discs



Brake callipers GranCabrio Sport
painted Blu
Drilled and slotted brake discs



Brake callipers GranCabrio Sport
painted Giallo
Drilled and slotted brake discs



Brake callipers GranCabrio Sport
painted Titanio
Drilled and slotted brake discs



Brake callipers GranCabrio Sport
painted Rosso Opaco
Drilled and slotted brake discs

STANDARD AND OPTIONAL EQUIPMENT

	GRANCABRIO	GRANCABRIO SPORT
SAFETY		
Bi-xenon headlights with headlight washing system	●	●
Adaptive headlights - with rotating lamps for a better cornering illumination	●	●
Automatic headlamp activation	●	●
Front indicators included into the headlamp	●	●
Front and rear foglamps	●	●
Taillamps with high visibility LED lights	●	●
Automatically dimming interior mirror	○	○
Automatically dimming exterior mirrors	●	●
Air-bag system: dual stage front bags, side bags head-thorax	●	●
Front seat belts with pre-tensions and load limiters	●	●
Rear seat belts with pre-tensions	●	●
Child seat ISOFIX attachments, rear	●	●
Telescopic roll-over protection system	●	●
Maserati Stability Program (MSP) - includes: - stability control (MSP) - traction control (ASR) - anti lock braking system (ABS) - electronic brake distribution (EBD) - engine torque control (MSR)	●	●
Tyre Pressure Monitoring System (TPMS)	●	●
Tyre sealing compound	●	●

WHEELS AND CHASSIS

Light alloy wheels - 20" Trident design coloured in silver (8,5J x 20" front; 10,5J x 20" rear)	●	○
Light alloy wheels - 20" Trident design coloured in Grigio Mercury (8,5J x 20" front; 10,5J x 20" rear)	○	○
Light alloy wheels - 20" Birdcage design coloured in silver (8,5J x 20" front; 10,5J x 20" rear)	○	○
Light alloy wheels - 20" Birdcage design coloured in Grigio Mercury (8,5J x 20" front; 10,5J x 20" rear)	○	○
Light alloy wheels - 20" Neptune design coloured in silver (8,5J x 20" ant; 10,5J x 20" post)	○	○
Light alloy wheels - 20" Neptune design coloured in Grigio Mercury (8,5J x 20" ant; 10,5J x 20" post)	○	○
Light alloy wheels - 20" Astro design coloured in silver (8,5J x 20" front; 10,5J x 20" rear)	○	●
Light alloy wheels - 20" Astro design Shiny Antracite Grey (8,5J x 20" front; 10,5J x 20" rear)	○	○
Skyhook - electronically variable active damping system	●	■
Skyhook - electronically variable active damping system - SPORT setup	■	●

	GRANCABRIO	GRANCABRIO SPORT
360 mm drilled brake discs - front; 330 mm drilled brake discs - rear	●	■
360 mm drilled and slotted brake discs - front; 330 mm drilled and slotted brake discs - rear	■	●
Power-assisted steering wheel, with speed sensitive features	●	●
Electronic Parking Brake (EPB)	●	●
18" space saver spare wheel	○	○

EXTERIOR EQUIPMENT

Metallic paintwork	○	○
Special colour	○	○
Bianco Fuji colour - pearlescent	○	○
Matt colours	○	○
Front grille with vertical and concave grille bars	●	■
Black look front grille with vertical and concave grille bars	○	●
Chromeline exterior trim (headlight, door handles, chromeline, front grille and side vents)	●	■
Black look exterior trim (headlights, shadowline, front grille and side vents)	○	●
Door handles in body colour	○	●
Front flick-up in body colour	■	●
Side skirts	●	■
Side skirts Sport	■	●
Door mirrors - electrically operated, folding and heated	●	●
Trident with chrome accents	●	■
Trident with red accents	○	●
Electric opening assist for boot lid and doors	●	●
Lightweight boot lid construction, with remote key opening	●	●
Maserati designation - rear	●	●
Rear parking sensors	●	●
Front parking sensors	○	○
Exhaust - twin dual tube tailpipes, in chrome plated stainless steel	●	■
Exhaust - single oval tailpipes, in black look	○	●
Car cover	○	○
Full automatic soft top	●	●

STANDARD ● OPTIONAL ○ UNAVAILABLE ■

INTERIOR EQUIPMENT

	GRANCABRIO	GRANCABRIO SPORT
GranCabrio logo on the dashboard	●	■
GranCabrio Sport logo on the dashboard	■	●
Under door sills - Cabrio design	●	●
Instrument dials in Maserati Blu color with white graph	●	●
Maserati clock design in centre dashboard with chrome-plated trim	●	●
Three-spoke sports steering wheel in leather multifunction	●	●
Steering column with manual height and reach adjustments	●	●
Maserati «Active Shifting»	●	■
Maserati «Active Shifting» (Trofeo design)	○	●
SPORT button for sport mode set-up	●	●
Front seats with high lateral support, electrically adjustable in height, depth, and backrest with «easy-entry» (the seat moves forward and backward automatically to facilitate the entry and exit of rear passenger).	●	●
Comfort pack front seats including:		
- Driver's seat memories	○	○
- Heating	○	○
- Power steering column with easy entry/exit function	○	○
Trident logo embossed on head restraints - front and rear	●	●
Folding front armrest with illuminated storage compartment	●	●
Fixed rear armrest integrated into the central tunnel	●	●
Two individual full size cup-holders - front and rear passengers	●	●
Lockable, illuminated glove compartment on passenger side - in dashboard	●	●
Storage compartment in centre tunnel - front and rear	●	●
Two air outlets - rear	●	●
Aluminium sport pedals	○	●
Windstop	○	○

ELECTRONIC DEVICES

	GRANCABRIO	GRANCABRIO SPORT
Electronic immobiliser	●	●
Alarm system (perimeter and volumetric sensing, anti-lift device, electronic immobiliser)	●	●
Remote key (on/off alarm system, lock/unlock doors, unlock boot lid)		
Cruise Control	●	●
HomeLink - Garage door opener	○	○
Dual zone automatic climate control with two rear air outlets in centre tunnel	●	●
Auto demist sensor	●	●
Maserati Multi Media System with 7» in dashboard screen - includes navigation system, RDS tuner, single CD player, 30GB hard disc drive	●	●
Text to speech system (to read SMS and TMC Premium traffic informations)		
Maserati Hi-Fi loudspeaker system - 6 speakers with 2 x 40 Watt + 4 x 25 Watt RMS integrated equalizer	●	●
Bluetooth® and USB port to upload audio files and MP3 files	●	●
iPod interface	○	○
Bose™ Surround Sound System with 12 speakers	○	○
Rain sensor	●	●

UPHOLSTERY AND TRIMS

Poltrona Frau™ leather upholstery	●	●
New M-design on the central area of the seats	■	●
Poltrona Frau™ drilled leather for central seats parts	○	○
Dashboard and tonneau cover coloured upon request	○	○
Dual interior colour leather upholstery with additional stitching	○	○
Coloured stitching upon request (excluding steering wheel and gear knob stitching)	○	○

STANDARD ● OPTIONAL ○ UNAVAILABLE ■

	GRANCABRIO	GRANCABRIO SPORT
Dark Chrome interior finishing	●	●
Glossy Black interior finishing	●	●
Moonwood wood trim on selected interior details (dashboard, door and rear panel mouldings, gear knob finishing)	○	○
Wengè wood trim on selected interior details (dashboard, door and rear panel mouldings, gear knob finishing)	○	○
Rosewood briarwood trim on selected interior details (dashboard, door and rear panel mouldings, gear knob finishing)	○	○
Walnut briarwood trim on selected interior details (dashboard, door and rear panel mouldings, gear knob finishing)	○	○
Carbalho wood trim on selected interior details (dashboard, door and rear panel mouldings, gear knob finishing)	○	○
Padouk wood trim on selected interior details (dashboard, door and rear panel mouldings, gear knob finishing)	○	○
High gloss colour for selected interior details in Black Piano and Blu Laque	○	○
Steering wheel and gear knob in coloured leather	○	○
Wooden steering wheel (Rosewood, Walnut briarwood, Wengè polished) and black leather	○	○
Wooden steering wheel (Rosewood, Walnut briarwood, Wengè polished) and coloured leather	○	○
Special range carpet piping upon request	○	○
Interior carpet colour upon request	○	○
Black soft top exterior and interior coloured in black	●	●
Black soft top exterior color with coloured interior (with specific colour matching)	○	○
Coloured soft top exterior with coloured interior (with specific colour matching)	○	○

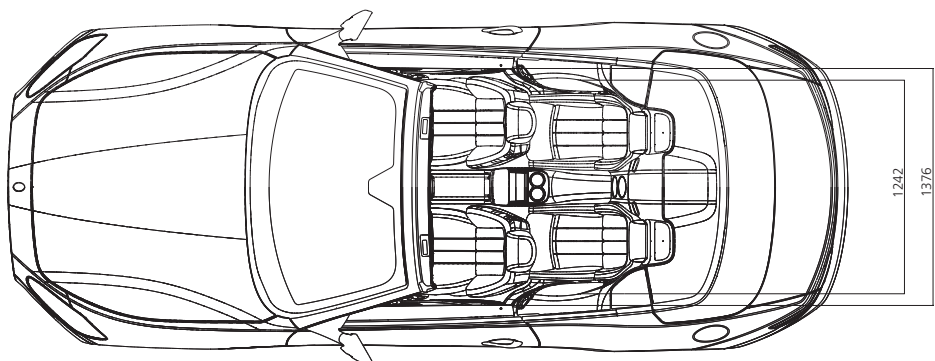
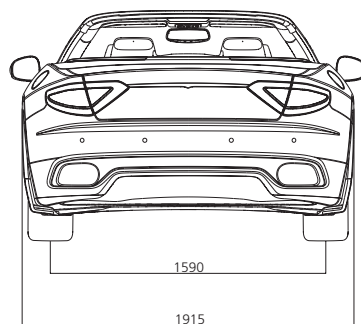
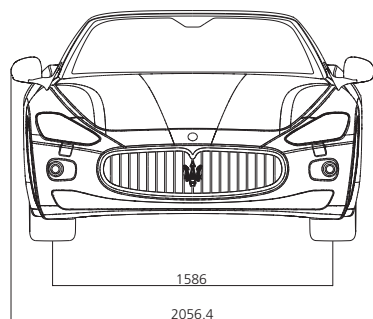
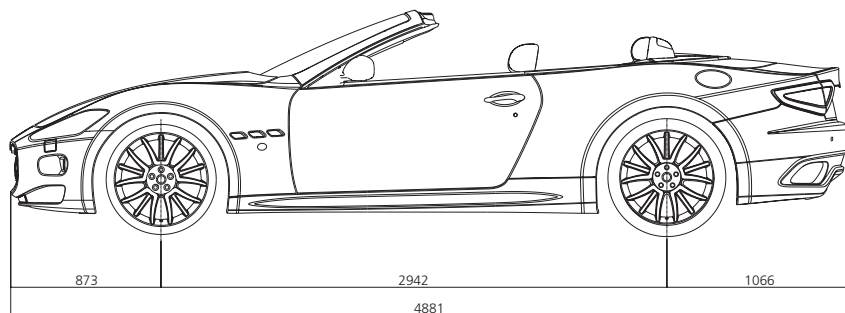

TECHNICAL SPECIFICATIONS	GRANCABRIO	GRANCABRIO SPORT
<ul style="list-style-type: none"> • Displacement • Bore • Stroke • Compression ratio • Max power output • Max power output revs • Max torque output • Max torque output revs • Max revs 	4.691 cm ³ 94 mm 84,5 mm 11,25 : 1 323 kW (440 HP) 7.000 giri/min 490 Nm (50 kgm) 4.750 rpm 7.200 rpm	4.691 cm ³ 94 mm 84,5 mm 11,25 : 1 331 kW (450 HP) 7.000 giri/min 510 Nm (52 kgm) 4.750 rpm 7.200 rpm
PERFORMANCE <ul style="list-style-type: none"> • Maximum speed • 0 to 62 mph acceleration • 0 to 400 metres acceleration • 0 to 1000 metres acceleration • 43 to 74 mph increase • Breaking distance from 62 to 0 mph 	175 mph with soft-top closed 170 mph with soft-top opened 5,3 sec 13.9 sec (to 105 mph) 24.8 sec (to 137 mph) 4,2 sec 35 mt.	177 mph with soft-top closed 171 mph with soft-top opened 5,2 sec 13.5 sec (to 109 mph) 24 sec (to 140 mph) 4,1 sec 35 mt.
CONSUMPTIONS AND EMISSIONS <ul style="list-style-type: none"> • Urban cycle • Extra urban cycle • Combined cycle • CO₂ emissions (combined cycle) 	22,5 l/100 km 9,8 l/100 km 14,5 l/100 km 337 g/km	22,5 l/100 km 9,8 l/100 km 14,5 l/100 km 337 g/km
DIMENSIONS AND WEIGHTS <ul style="list-style-type: none"> • Length • Width (with side mirrors) • Width (without side mirrors) • Height • Wheelbase • Front track • Rear track • Front overhang • Rear overhang • Front alloy wheels • Rear alloy wheels • Front tyres • Rear tyres • Turning circle • Boot capacity • Fuel tank capacity • Dry weight (EU version) • Kerb weight (EU version) • Kerb weight + driver • Full load weight • Gross vehicle weight • Weight distribution 	4.881 mm 2.056 mm 1.915 mm 1.380 mm 2.942 mm 1.586 mm 1.590 mm 873 mm 1.066 mm 8,5Jx20" 10,5Jx20" 245/35 ZR20" 285/35 ZR20" 10,7 mt. 173 l 75 l 1.887 kg 1.980 kg 2.055 kg 2.280 kg 2.350 kg 49% front; 51% rear with soft-top closed 48% front; 52% rear with soft-top opened	4.881 mm 2.056 mm 1.915 mm 1.380 mm 2.942 mm 1.586 mm 1.590 mm 873 mm 1.066 mm 8,5Jx20" 10,5Jx20" 245/35 ZR20" 285/35 ZR20" 10,7 mt. 173 l 75 l 1.887 kg 1.980 kg 2.055 kg 2.280 kg 2.350 kg 49% front; 51% rear with soft-top closed 48% front; 52% rear with soft-top opened
<ul style="list-style-type: none"> • Soft top folding time 	28 sec.	28 sec.

THE ENTIRE MASERATI WORLD

*A WORLD OF COMPETITION,
PASSION AND SERVICES
DEDICATED TO THOSE WHO LOVE MASERATI*





MASERATI AND RACING A LONGSTANDING TRADITION OF SUCCESS IN MOTORSPORT

Motor racing has always been the test-bed of the automotive industry, where innovative ideas are put through their paces before being applied to roadgoing cars. In its eternal quest for excellence, Maserati runs an extensive motorsport programme through which it tests devices, technologies and materials to assess their suitability for everyday use – a practice that dates back to the company's inception in 1914.

TROFEO MASERATI GRANTURISMO MC

Maserati is once again the star of the international racing scene, thanks to the Trofeo Maserati GranTurismo MC - an eight-race championship for gentleman drivers throughout Europe that is run alongside the World Touring Car Championship. Using the GranTurismo MC Trofeo, the racing version of the GranTurismo S, participants can contest the championship with all cars prepared to an equal standard and managed directly by Maserati Corse. In addition, private teams can purchase a GranTurismo MC GT4 to compete in a separate class distinct from the Trofeo cars.

At each meeting there are two free practice sessions on the Friday (40' each), two qualifying sessions on the Saturday (20' each) and two races lasting 38' + 1 lap on the Sunday.

For information email:

Trofeomaserati@maserati.com





INTERNATIONAL SUPERSTARS SERIES

Maserati is one of the leading makes in the International Superstars Series, with two Quattroporte Sport EVO cars operated by the Swiss Team. The cars, derived from standard production models and sporting the 4.7 litre V8 engine, are driven by Andrea Bertolini, official Maserati test driver and current FIA GT1 world champion, and Alessandro Pier Guidi. Maserati is taking on a tough field of cars, built by no fewer than nine major manufacturers. The championship includes nine races on circuits all over Europe and, thanks to rules aimed to balance the various cars' power and performance, it is offering thrills and excitement to both drivers and spectators alike.





MASTER MASERATI DRIVING COURSES

It is perhaps the ultimate driving experience: taking to the racetrack in a race-tuned Maserati. A Master Maserati Driving Course places you behind the wheel of various different Maserati models, so that you can learn about performance driving and other techniques that will enable you to appreciate your own Maserati's performance, whilst at the same time improving your driving skills. The courses are open to existing Maserati owners and potential buyers, and comprise a combination of theory and practice that has been fine-tuned over the years. They take place at the Paletti di Varano de' Melegari, near Parma, a demanding circuit that puts even the best drivers to the test and which features special driving instruction facilities. The sessions are run under the expert direction of ex-Formula 1 driver, Ivan Capelli, who is ably assisted by a highly experienced team of professional instructor-drivers.

There are four types of Master Maserati course:

MASTER WARM-UP

This course, lasting one day, is intended for those wanting to improve their driving technique at the wheel of a Maserati, and is the ideal introduction to the more advanced courses. The overall aim is to enhance the participants' personal driving skills in an enjoyable yet challenging environment.

MASTER GT

This is an all-inclusive two-day course that is spent at the wheel of various different Maseratis. It comprises a sequence of exciting and dynamic sessions including cornering trajectory technique, acquisition and analysis of Formula One type telemetry data, and driving with a pace-car. In addition, delegates are taught how to control the car in different simulated road conditions, e.g. quick direction changes, skid situations, and emergency braking.





MASTER HIGH PERFORMANCE

The Maserati Master High Performance course is the next step up from the Master GT programme - an intensive one-day course that provides a unique opportunity to get to grips with the Maserati GranTurismo and other high performance Maseratis. The programme includes advanced high-speed driving sessions and technically more complex, challenging exercises.

MASTER MC TROFEO

The Master Maserati MC Trofeo is the ultimate expression of the sports driving courses developed in the previous High Performance programme.

The course, an unforgettable and thrilling experience with a highly professional and technically advanced programme, gives you the once-in-a-lifetime chance to be part of the Maserati competition world, and drive the cars competing in the Trofeo Championship on the Varano de' Melegari circuit.

For informations and registration:

Maserati Master Office

Tel. : +39 0525 55 11 38 - Fax : +39 0525 55 11 40

info@mastergt.it - www.maserati.com



THE TAILOR-MADE SERVICES OF THE MASERATI WORLD

INDIVIDUALLY TESTED

Before approval and delivery to the customer, each car is not only inspected and run in on the test bed, but also directly test-driven on the road by expert test-drivers for about 50 km.

FACTORY DELIVERY

Customers may choose to take delivery of their cars in Modena itself, at the historic Maserati production location, in the fascinating Showroom designed by Ron Arad. They will also be able to tour the production line to see for themselves how a Maserati is built.

THREE-YEAR WARRANTY AND ROADSIDE ASSISTANCE SERVICE

Maserati guarantees the quality and performance of its cars for 36 months, with unlimited mileage. The Maserati Assistance Service is provided free of charge for 3 years (with unlimited mileage) and comprises an exclusive package of services in addition to the standard warranty cover. The services included are roadside assistance, replacement car, taxi for collection and return of replacement car, homeward or outward travel for passengers, collection of the repaired vehicle, hotel cost, repatriation of vehicle for repair from abroad, money advance for essentials, motoring information (in Italy only) and information about the Maserati authorised dealership network. These services are provided through the relative Assistance Centres, operating 24 hours a day, 365 days a year.

MASERATI EXTENDED WARRANTY

All Maserati GranCabrio, GranTurismo, Quattroporte, Coupé, Spyder, GranSport and GranSport Spyder owners can extend their vehicle's standard warranty for a further 12 or 24 months with unlimited mileage. This enables them drive their car for up to 5 years with complete peace of mind. The Extended Warranty can be activated at any time before the standard warranty expiry date* provided that the car's mileage does not exceed 100,000 km. For details of the Maserati Extended Warranty programme, please contact your nearest Maserati dealer.

* in the case of extension for the 5th year, the warranty must be extended by the end of the 4th year warranty extension



MASERATI

CERTIFIED PRE-OWNED

MASERATI CERTIFIED PRE-OWNED

The exclusive programme that guarantees the best pre-owned Maserati vehicles for 12 or 24 months with no mileage restrictions. To benefit from the same type of services as new cars, a pre-owned Maserati has to pass 120 strict technical checks. With this certification, the car effectively complies with the highest quality standards and is able to satisfy even the most detail-conscious client. The client receives only the timeless pleasure and thrill of driving their own Maserati.

*FACTORY TOUR**

Find out where and how the Maserati myth is born.

Maserati offers you the opportunity of finding out about its secrets from the inside, through a guided tour of the Modena production plant. Discover how the cars are born, learn their secrets, fully understand their engineering and really feel one of the Maserati family.

*Tours are only arranged by appointment and can be booked through dealers all over the world.

WEB E CAR CONFIGURATOR

The www.maserati.com web site lets users browse every aspect of the Maserati world at ease, with multimedia content, historical information, a search function for pre-owned Maserati cars in the authorised sales network, and the futuristic car configurator. To give you access to all the infinite ways in which every Maserati can be personalised, we have created an innovative, absolutely unique car configurator. Within it, you can create your own Maserati by making all the choices available when configuring the car, and admire its every detail thanks to innovative features such as “X-Ray” viewing.

Create your Maserati on www.configurator.maserati.com.

MASERATI EXPERIENCE**

For those wishing to combine their Maserati factory visitor with more insight into the firm’s home city of Modena: its culture, history and cuisine.

The Maserati Experience programme, lasting one or more days, enables you to get to know the context of the Maserati world at first-hand: Modena, with its works of art, its history and its fine food.

You can tailor your Maserati Experience to your personal tastes by combining a variety of activities:

- Panini Museum and/or Stanguellini Museum visit
- Guided tour of the town
- Guided tour of a traditional balsamic vinegar establishment, with tasting
- Guided tour of a winery, with tasting of local wines
- Cooking school

... and much, much more.

** For more information please contact us by writing to: maseratiexperience@maserati.com





MASERATI COLLECTION

Share the Maserati passion, even in your “accessories”, and enjoy membership of world of pure excellence. The exclusive Maserati Collection produces are available from all official Maserati Dealers and from the Maserati Store at the Maserati Showroom in Modena.

All articles can also be purchased directly from your home, using the www.maseratistore.com internet site, the on-line store for customers wishing to order and receive the articles in the Maserati Collection anywhere in the world.

MASERATI CLUB

For sharing thrilling moments with other Maserati owners. The owners of Maserati cars from every era can fully enjoy the pleasure of driving a Trident sports car by taking part in a calendar of touring and racing events exclusively for Maserati Club members. The Maserati Club provides the link between the past, present and future of the Modena constructor. The association is led by personalities who have made a fundamental contribution to the growth and promotion of Maserati in all eras, starting from Maria Teresa de Filippis, the first woman F1 driver and today a proud supporter of the marque. Becoming a Maserati Club member is simple: the events schedule and membership forms are available from Maserati Dealers.

For more information www.maseraticlub.com

ORIGINAL MASERATI ACCESSORIES

Especially designed to ensure complete customer satisfaction, original Maserati accessories represent the perfect combination of design and functionality, complete with a guarantee of the highest quality, a characteristic that has always been associated with our brand.

The range of original accessories includes *ad hoc* items designed to enhance the elegance and sporty appeal of Maserati models. Exterior features including coloured radiator grilles or brake callipers; interior finishings, such as carpet overlay kits and under-door moulding covers; components associated with sporty dynamics with a wide choice of alloy rims and carbon trims; travel and car care accessories such as car covers, battery tenders, child car seats and luggage sets specially designed for the various cars. These are just some of the many articles available to enable customers to make their driving experience on board their Maserati cars truly unique.

MASERATI CLASSICHE

Intended for enthusiasts and owners of vintage Maserati cars, the Maserati Classiche organisation serves all those who wish to re-live the marque's glorious past. The Maserati Classiche range of products includes articles that highlight the company's great heritage, built up over more than ninety years of history: paintings of the most glorious moments and the cars that have gone down in the history of world motor sports, original reproductions of period parts catalogues, owners' handbooks and brochures for past models, merchandising articles such as clothing and scale models, and much more.

All the latest items are available on www.maserati.com in the Passion - Maserati Classiche section and at the email address maserati.classiche@maserati.com.



MASERATI WORLDWIDE

NORTH AMERICA

Canada
USA

CENTRAL / SOUTH AMERICA

Argentina
Brazil
Chile
Colombia
Costa Rica
El Salvador
Guatemala
Mexico
Panama
Puerto Rico
Dominican Republic
Venezuela

EUROPE

Austria
Belgium
Bulgaria
Cyprus*
Denmark
Finland
France
Germany
Greece
Italy
Israel
Luxembourg
Latvia
Monte Carlo
Norway*
Holland
Poland
Portugal

*Service Only

United Kingdom
Czech Republic
Romania
Russia
Slovenia
Spain
Sweden
Switzerland
Turkey
Ukraine
Hungary*

ASIA / OCEANIA

Australia
China
Korea
Philippines
Japan
Hong Kong
India
Indonesia
Malaysia
New Zealand
Singapore
Taiwan
Thailand

AFRICA / MIDDLE EAST

Saudi Arabia
Bahrain
Egypt
United Arab Emirates
Kuwait
Lebanon
Oman
Qatar
Syria
South Africa





MASERATI CONTACT CENTRE:

Italy - 800 008 008 • Switzerland (German) - 0800 837 100 • Switzerland (French) - 0800 837 200 • Switzerland (Italian) - 0800 837 300 • Germany - 0800 810 80 80 • Sweden - 020 798 000 • Norway - 800 180 88 • Finland - 0800 110 808 • Austria - 0800 281 888 • France - 0800 908 000 • Monaco - 800 93 888 • Denmark - 80 888 000 • Belgium (Flemish) - 0800 710 31 • Belgium (French) - 0800 710 30 • Luxembourg - 8002 8000 • Holland - 0800 0 224 234 • Spain - 9009 969 45 • Portugal - 8008 39 103 • Greece - 00800 3912 725 41 • Turkey - 00800 399 090 538 • United Kingdom - 0800 064 6468 • Latvia - 0371 7500 100

INTERNET: www.maserati.com



The illustrations and texts contained in this brochure are based on the information available at the time of production and do not contain a description of specific characteristics of the car by the Constructor. Some models, equipment and accessories may not be available or may only become available after the car's launch on the market. Maserati reserves the right to modify colours, designs and technical features at any time and without forewarning. Official Maserati Dealers will be glad to provide further details and updates in this regard.



WWW.MASERATI.COM

WWW.MASERATIGRANCABRIO.COM

MASERATI SPA • VIALE CIRO MENOTTI, 322 • 41121 • MODENA • ITALIA