



MASERATI

EXCELLENCE THROUGH PASSION

MASERATI GRANTURISMO MC STRADALE



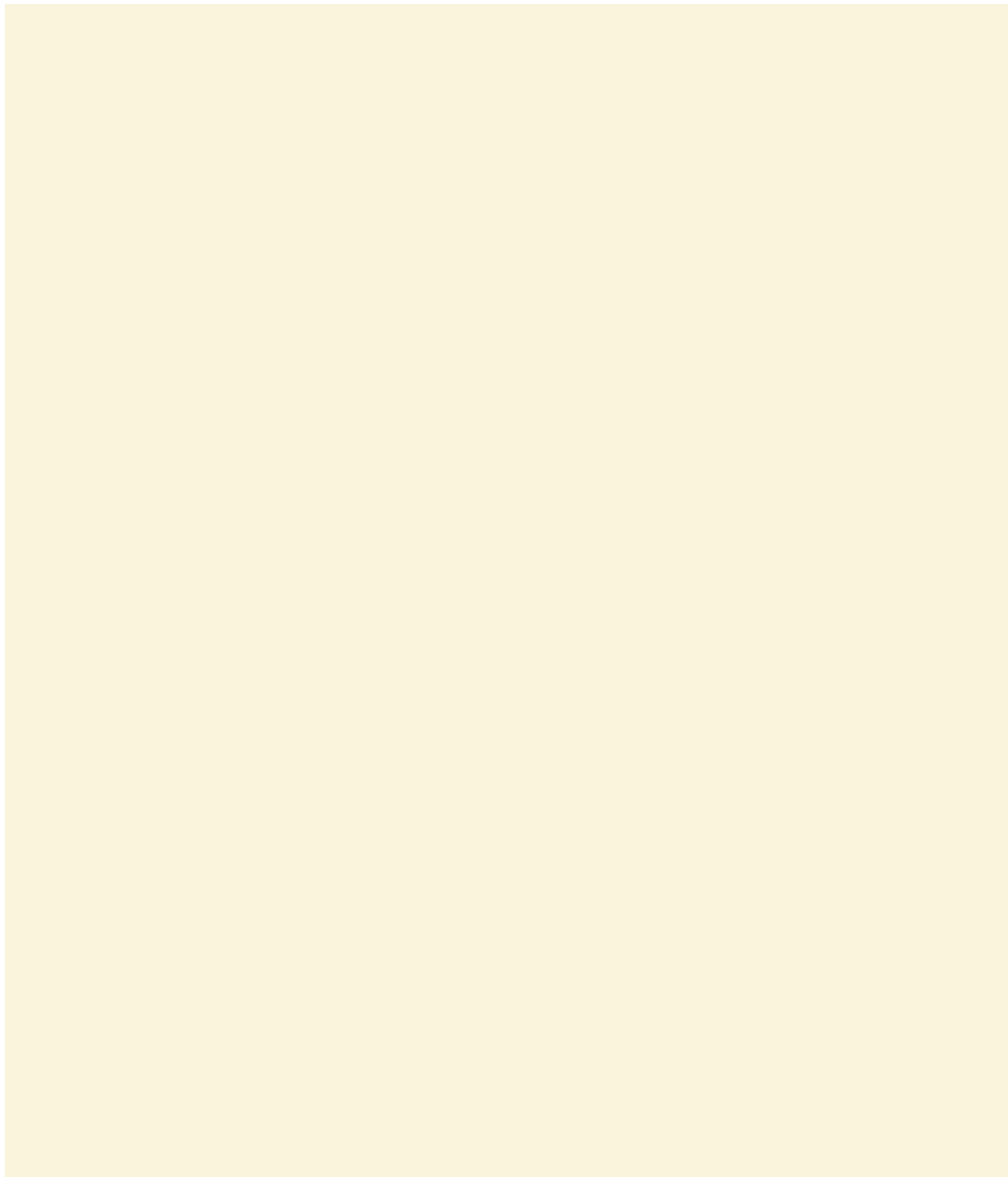

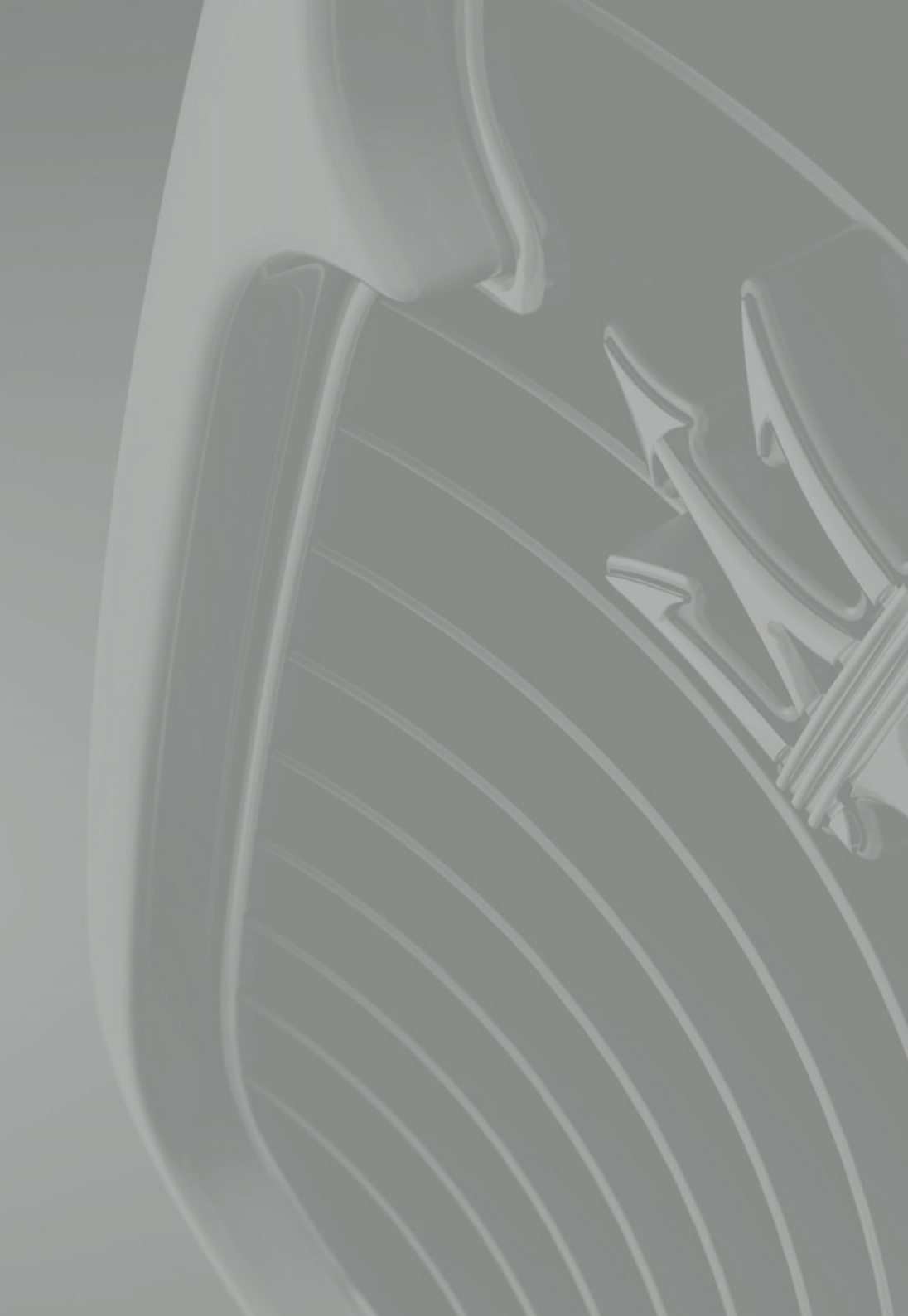

MASERATI

EXCELLENCE THROUGH PASSION

Maserati epitomises a long Italian tradition of designing and building fine cars. A tradition of striving for perfection in every detail. Enabling drivers to thrill to the power of thoroughbred engines, while ensuring the comfort and pleasure of each and every passenger. Each new Maserati is a testament to the marque's rich history, carrying with it an unrivalled racing pedigree, luxurious comfort and an unmistakable style.

RACE INSPIRED LUXURY	4
ELEGANCE AND POWER	12
THE POWER OF BEAUTY	23
A CUSTOM-MADE MASTERPIECE	40
THE WORLD OF MASERATI.....	51

GRANTURISMO MC STRADALE. RACE INSPIRED LUXURY.

The GranTurismo MC Stradale is the pinnacle of Maserati's knowledge. A road car with racing genes. A unique two-seater with the unmistakable style of the GranTurismo, renowned for its performance, design and comfort. But it is also a car with the sporting heritage of Maserati Corse, whose name it wears with pride, a synonym of adrenaline, competition and continuous development. On the one hand, a heritage of Italian craftsmanship and attention to detail. On the other, technology tried and tested on the track for unbeatable performance. This is the synergy that has given birth to Maserati's fastest, lightest and most powerful car. The GranTurismo MC Stradale is the first model in the Maserati range to break the 300 km/h barrier.





**OUTSTANDING ROAD PERFORMANCE:
THE GRANTURISMO RANGE.**

Maserati's newest car's unique style is inherited from the family to which it belongs: the GranTurismo range, four-seater cars of unparalleled elegance and performance, the perfect marriage of luxury and sports.

The range reached its ultimate expression with the GranTurismo S. The ideal car for anyone looking for uncompromising handling on the road, this sports version of the coupé, designed by Pininfarina and powered by a V8 4.7L engine, is the hallmark of exclusivity and performance, making excitement part of your everyday experience.

While the GranTurismo MC Stradale takes its style from the GranTurismo S, its inspiration owes much more to the track than the road.









**EXCELLENCE ON THE TRACK:
THE GRANTURISMO MC TROFEO.**

Unbeatable performance. Ever more advanced technical solutions to drive reliability and handling. It's on the track, on the best race circuits around the world, that Maserati develops the sports potential of its cars. From the FIA GT1 World Championships, where it took first place with the MC12, to the Trofeo Maserati GranTurismo MC for gentleman drivers, every competition in which Maserati Corse participates is an opportunity to set new standards, and the GranTurismo MC Stradale is the most recent outcome of this interchange between Maserati's racing activities and its road cars.

The new Maserati inherits its unique design from its racing sibling, the GranTurismo MC Trofeo, developed in response to racing needs with innovative solutions tested on the unforgiving environment of the race track: because it's only on the track that you can push cars to their limits.

The GranTurismo MC Stradale is the outcome of the hand-in-hand development of Maserati's race and road cars: the symbol of synergy and the search for excellence.





ELEGANCE AND POWER.

When the excellence of Maserati combines with the adrenaline of Maserati Corse, the result has to be the perfect mix of elegance and power, the epitome of beauty and sporting aggression: the new GranTurismo MC Stradale. Its bodywork is the perfect solution to the combined demands of aerodynamics and aesthetics, while the interior, featuring prestigious materials like Alcantara®, perfectly combines luxury with performance.





Maserati

GT 450 MC



NEW BODYWORK STYLING.

Inspired directly by Maserati Corse, the streamlined styling of the GranTurismo MC Stradale makes a statement of excellence, while expressing its ability for high performance.

Our experience of racing and computational fluid dynamics have led to the definition of an aerodynamic envelope with 25% more downforce at the front and 50% more at the rear at 200 kph compared to the GranTurismo S. In particular, the front spoiler, side miniskirts and slots in the front wings combine to push the front of the car down at high speeds, cool the brakes, extract hot air from the brake circuits as well as delivering downforce to the entire car. The miniskirts have been designed to integrate with

the vents to channel airflow under the car body, thus further increasing downforce. The car's highly sophisticated aerodynamics includes two slots on the bonnet to cool the engine compartment.

At the rear, the bumper has been redesigned for centrally located exhausts and the extractor profile designed to promote efficient air flow from under the body. These apertures further stabilise the air flow behind the car, thus increasing aerodynamic efficiency. The rear spoiler, finally, produces additional downforce at high speeds.

The rims are equally sophisticated: the 20" flow-formed rims of the GranTurismo MC Stradale are not only lighter, but also bear the unmistakable Trident symbol on their double spokes – another statement of Maserati tradition.



INTERIOR.

The unique design of the new GranTurismo MC Stradale is fully expressed in the interior, with numerous details combining to create an environment of luxury and excitement: the new lightweight, race-derived wrap-around seats, the combination of leather and Alcantara® upholstery, redesigned instrument panel and a new dashboard layout.

At the front, the new seats – upholstered in high tech materials with the Trident symbol embroidered on the headrests – offer excellent support in all driving conditions. The rear shell frame is carbon fibre, and they are equipped with manual lengthwise and seatback angle adjustments.

The overall styling of the dashboard is very different from that of the GranTurismo S: in line with the car's more sporting concept, the luxury chrome detailing has been replaced with a more aesthetic styling in black, for a racing cockpit feel. Alcantara® has been used for the central console, the armrest compartment cover, the door panel armrests, handles and the dashboard binnacle hood.

This combination of sports and elegance continues at the rear, which has been redesigned to create a storage panel with refined materials and detailing, including an Alcantara® cushion embroidered with the headrest Trident symbol.





DASHBOARD AND INSTRUMENT PANEL.

This new performance-orientated addition to the GranTurismo range is highlighted by the new dashboard. A car with these levels of performance must have direct, intuitive controls: the central console has been designed to meet this requirement with the Sport and Race buttons, two controls which optimise the car's handling for different conditions at a single touch.

The evolution of the interior has also transformed the instrument panel, where Maserati's traditional blue background has been replaced by black, with completely new white graphics. The display has also been updated to include the "MC-R" warning to indicate that the car is now in quick shift mode.

COMFORT.

In the GranTurismo MC Stradale both the driver and passenger will be able to enjoy the car's exceptional comfort and attention to detail. Both the front seats are designed with a sports configuration of both the seat and seatback for outstanding comfort, as well as supporting the torso and legs in high speed cornering. They also ensure an ergonomic seating posture which prevents fatigue even during long drives.

In the same way, the controls have an ergonomic layout and design, for comfort, stability, practicality and safety in all conditions.



11:03 27°C

Lun 31 Agosto

1

AUTO

km

km/h

201

0



AIRBAG



Maserati











THE POWER OF BEAUTY.

Having been developed from a racing car, the GranTurismo MC Stradale is an exciting and powerful road car. This is due to its engine, more powerful than that of the GranTurismo S, its significantly reduced overall weight, innovative carbon ceramic brake system, improved suspension and, above all, the new MC-Race mode, available at the press of a button, which makes the GranTurismo MC Stradale more responsive and dynamic than ever.



MC RACE MODE.

As a car which marries the race track to the road, the GranTurismo MC Stradale offers the driver three driving modes: Auto, Sport and Race; the newest and most dynamic of the three.

In every mode, the accelerator is more responsive than that of the GranTurismo, but it is the Race option that gives the most exciting ride. Race mode is activated at the touch of a button in manual gear mode, and maximises performance of all parameters, rendering the GranTurismo MC Stradale more responsive than ever. In particular, it differs from Sport mode, in which the exhaust bypass valve can be opened at over 4000 rpm to give a more exciting sound. In Race mode gear changes take place in just 60 milliseconds thanks to the computerised shift control. It also offers the option of Sequential Downshifting, which works by the driver simply holding in the down-shift paddle on the left of the steering column while braking. The car will keep changing down gears at exactly the right moment as the speed lowers until the driver releases the gear-shift paddle. This is very useful when a section of road turns from a long, fast section into a tight turn, where the GranTurismo MC Stradale driver only needs to make one movement to select the correct gear, rather than a series of gearshifts.



ENGINE.

The heart of the GranTurismo MC Stradale is its V8 4.7L engine, which puts out 450 hp (336 kW) at 7000 rpm, an increase of 10 hp over the GranTurismo S. Power, flexibility and instant response when cornering are all heightened by the 20 Nm greater torque (from its previous formidable 490 Nm the engine now boasts 510 Nm at 4750 rpm) with a steeper torque curve at lower revs.

Many of the improvements to the V8 engine are due to reduced friction, thanks to the redesigned oil sump fluid dynamics and DLC coating (Diamond-Like Coating) on the tappets and camshaft lobes. The result is a more powerful engine with reduced consumption and consequently lower emissions, which gives unbeatably fluid gear changes while responding to the accelerator with an aggressive thrust and roar, controlled by the pneumatic exhaust system valves.

Furthermore, just like on the GranTurismo S, the engine, with its steel cylinder liners, is exceptionally light and compact, especially along the car's main axis. The optimised dynamics are also due to the single chain timing system which gives a lighter response, improved reliability and reduced consumption.

Finally, in line with Maserati's most recent philosophy, the engine features a wet sump lubrication system, which reduces the number of oil recovery pumps and considerably reduces running noise: all to the advantage of the perfect combination of comfort and sports performance.



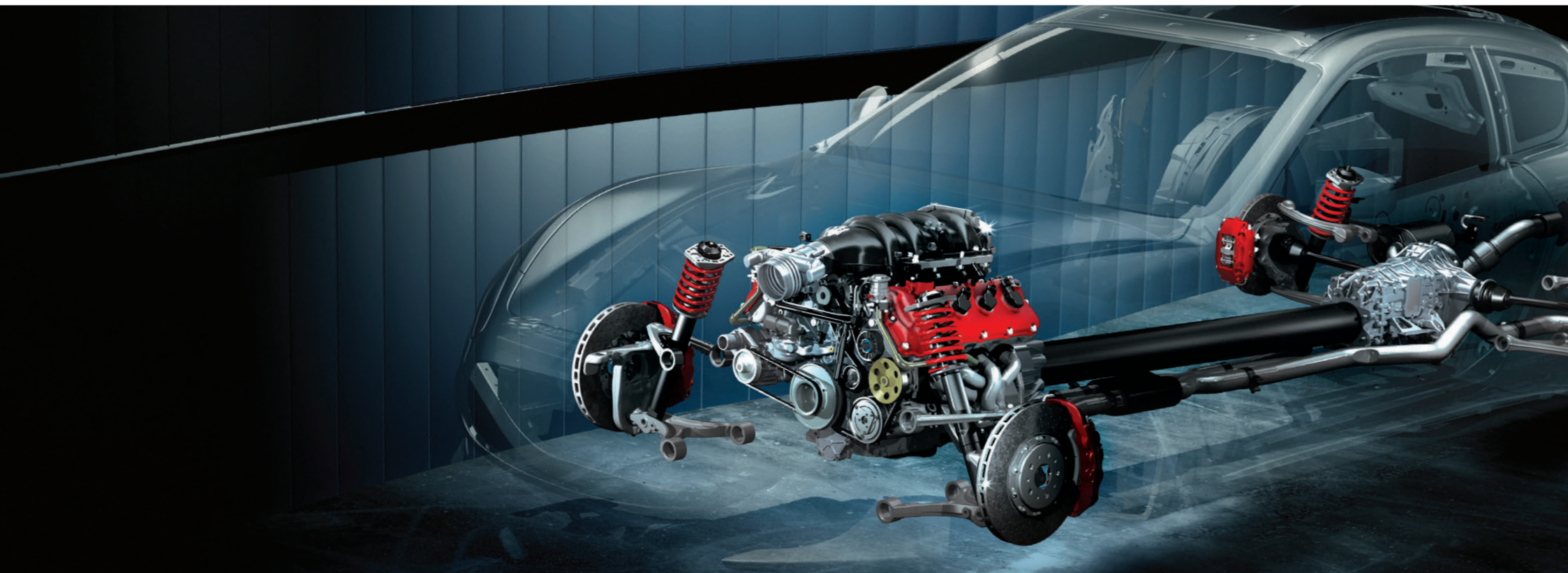

REDUCED WEIGHT.

Throughout its glorious history, Maserati has paid special attention to finding the right mix of performance, mass distribution and overall weight. While the car's weight is biased towards the rear, the GranTurismo MC Stradale is lighter weight than any current Maserati: an exceptional achievement which sets a new bar in the area of performance.

Maserati engineers have achieved their objective by selecting all components with an obsessive attention to detail, including the new Brembo

carbon ceramic brakes (lighter than the dual cast alloy brakes of the GranTurismo S) and special 20" MC-Design alloy rims, designed for an aggressive look and flow-formed for even lower unsprung weight.

The search for light weight has not left the cockpit untouched – it has been extensively simplified in comparison to that of the GranTurismo S, while maintaining Maserati's unmistakable style and detailing, and making no concessions in terms of comfort.



SUSPENSIONS.

For the highest-performing car in the GranTurismo range, a set-up 10mm lower has been developed for absolutely unbeatable handling and driving pleasure.

As well as stiffer dampers, the GranTurismo MC Stradale includes larger-diameter roll bars which minimise lateral load shifts (roll angle -20%); overall, the car's rigidity is increased by 16% at the front and 32% at the rear. The new set-up is combined with a special MSP calibration, which gives the driver greater freedom of action.

EXHAUST AND BYPASS VALVE SYSTEM.

A Maserati like this, designed for the road but developed from racing, must have an intense, unmistakable sound: this has been achieved by perfectly matching the exhaust with the insulation and using lighter rear silencers for a richer, more satisfying sound. The exhaust is also equipped with a hinged silencer bypass valve to further enhance the GranTurismo MC Stradale sports identity. The valve is permanently open in Race mode, and opens at over 4000 rpm in Sport mode.

But the car doesn't just sound like a race car. Just like race track cars, the exhausts are located higher and more centrally, like on the GT4 and Trofeo: this is a significant detail which further emphasises the character of the GranTurismo MC Stradale.





BRAKING SYSTEM.

Innovation in braking systems is a Maserati tradition. Today, tradition meets the future: after the introduction of dual cast disc brake technology, the GranTurismo MC Stradale is equipped for the first time in the company's history with carbon ceramic brakes.

These brakes are lighter and more powerful than conventional brakes, and following rigorous testing on the Nürburgring, Fiorano, Le Castellet (Paul Ricard) and Balocco race tracks, have proved their ability to handle the very high stresses typical of racing, thus making them an exceptional solution to the durability and response requirements of high performance road driving.

The heart of the new system is a larger master cylinder (27 mm diameter, compared to the previous 25 mm) with Brembo carbon ceramic brakes, 60% lighter than conventional brake discs of the same size. The front end is equipped with 380 mm x 34 mm ventilated discs, with fixed six-piston caliper. The larger rear discs measure 360 mm x 32 mm, with fixed four-piston caliper. The brakes are designed and calibrated to provide the highly appreciated gradual braking of the GranTurismo S in everyday driving. The new aerodynamics of the GranTurismo MC Stradale also provides each brake with its own integrated two-part cooling system, with a duct conveying cold air directly from the grille to the centre of the disc. A slot in the front wing generates more even air flow and extracts hot air from the braking system.

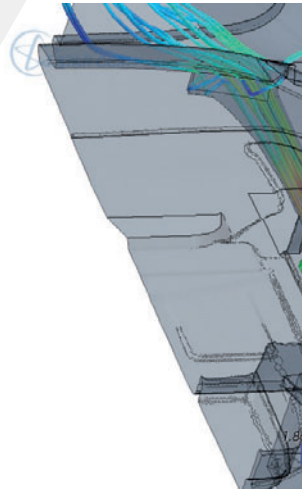

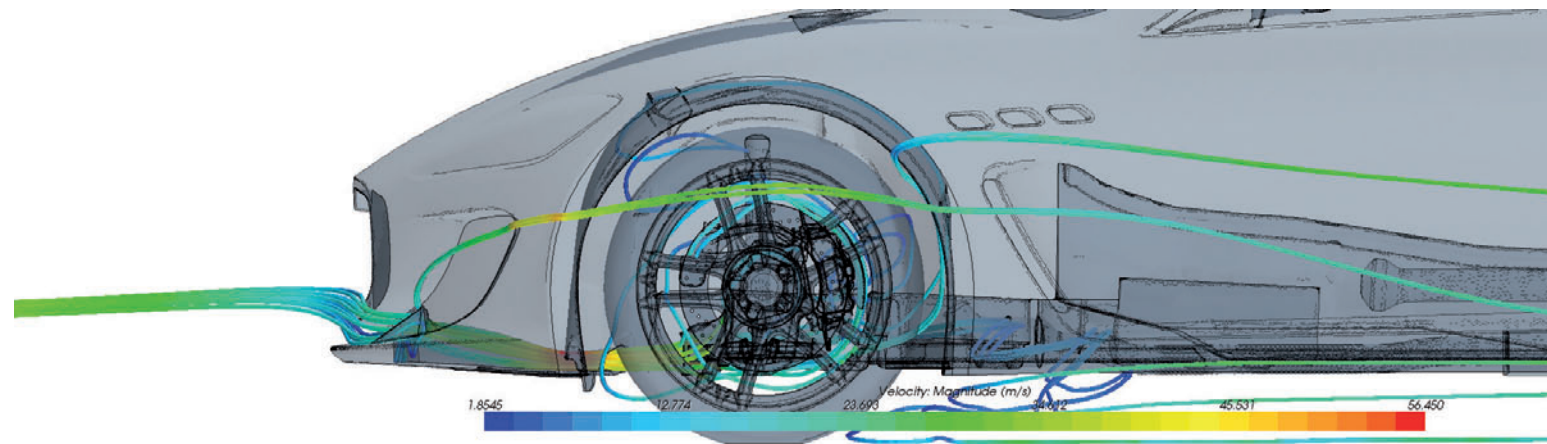
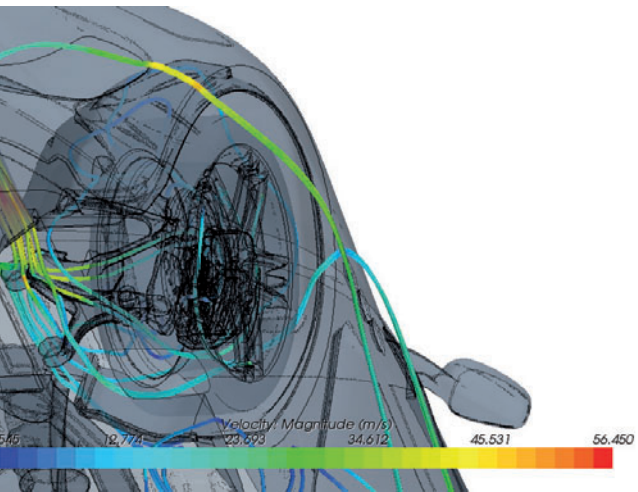

With such innovations, the GranTurismo MC Stradale matches the engine's formidable power and acceleration with effective and responsive braking. Thanks to the high performance Brembo brakes with their instant

response in all conditions, the car can stop from 100 kph in just 33 m, with an average deceleration of 1.2 g.



TYRES.

The GranTurismo MC Stradale is equipped with the latest generation of sports tyres (255/35 ZR20 front and 295/35 ZR20 rear) developed by Pirelli, who also make the tyres for the GranTurismo MC Trofeo.

Designed for perfect performance on both road and track, the 20" Pirelli PZero Corsa tyres are slightly wider than those provided as standard equipment on the GranTurismo S and offer increased grip without compromising handling and comfort. Thanks to their design and the use of materials conceived and refined by Pirelli for racing, they guarantee unbeatable grip and response, together with improved precision and constant efficiency even on the track.

The rear tyres feature an asymmetrical tread with large blocks on the outer shoulder for improved lateral grip, while the front tyres have a directional tread for outstanding grip on both wet and dry surfaces.

SAFETY.

ACTIVE SAFETY.

The new GranTurismo MC Stradale can boast exceptional control and safety in all conditions, thanks to its advanced control logic, the MSP (Maserati Stability Programme) system which is always active in the background, without depriving the driver of the sensation of total control at all times. Thanks to a balanced weight distribution (48,5% front - 51,5% rear), obtained by moving the engine back behind the front axle, road holding and grip under acceleration are also outstanding.

MASERATI STABILITY PROGRAMME (MSP).

Like all the cars in the range, the GranTurismo MC Stradale is also equipped with the Maserati Stability Programme (MSP) which, when the car initiates a skid, reduces torque, activates the brakes and stabilises the car in just a few milliseconds. Furthermore, the ABS system prevents the wheels locking while braking, distributes braking force between the front and rear axles to prevent the rear wheels skidding and prevents the drive wheels losing grip on low grip surfaces. When the Sport mode button is pressed, the action of the MSP is moderated to provide more sporty handling – although without compromising safety. The cut-in threshold is moved upwards and the system acts primarily on the brakes without affecting engine power delivery.

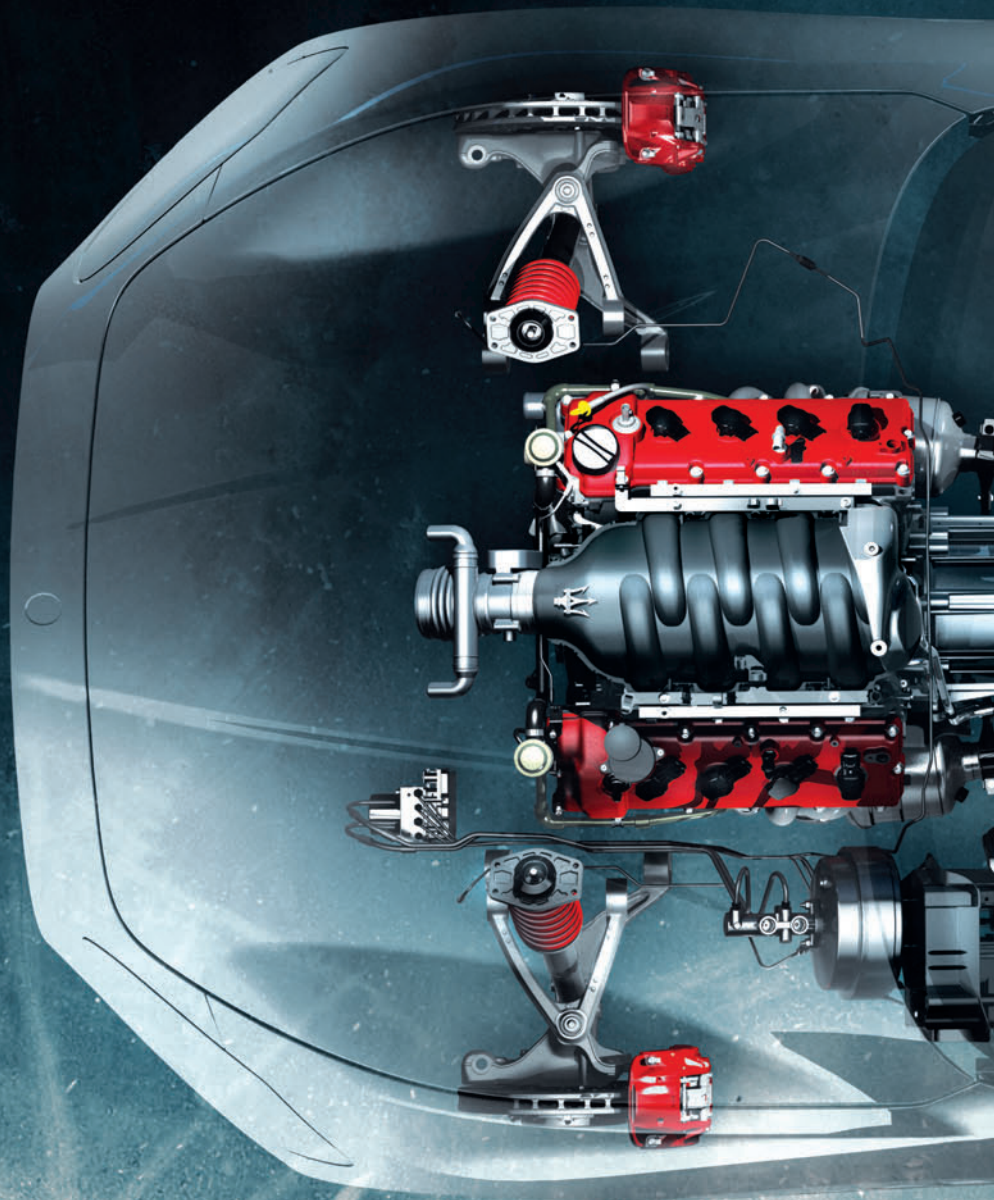

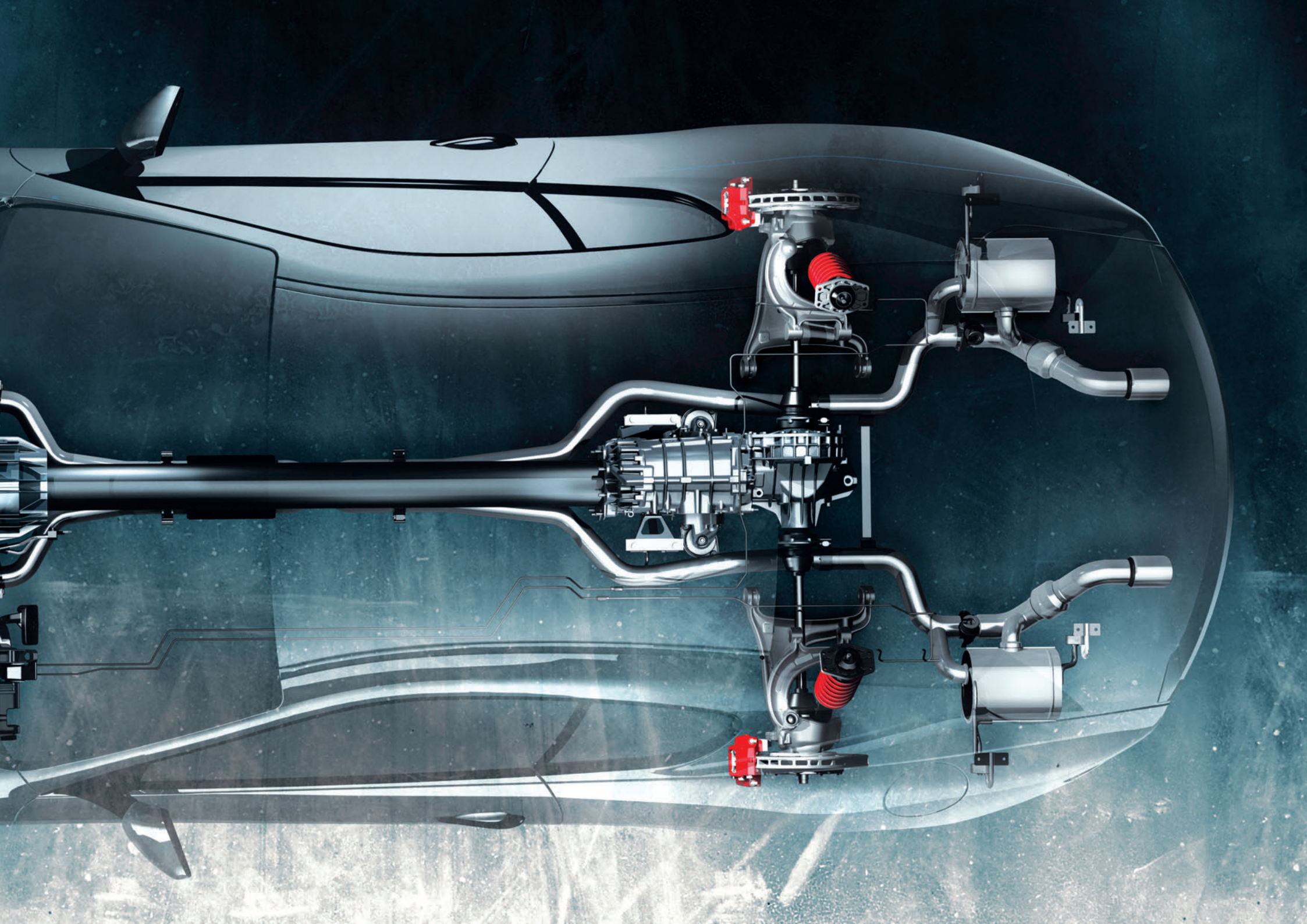



HYDRAULIC BRAKE ASSIST (HBA).

The GranTurismo MC Stradale is also equipped with the HBA system which recognises panic situations by analysing a combination of parameters such as the servobrake pressure gradient, wheel speed and illumination of the third stop light. The servobrake ECU analyses these parameters and takes over from the driver in activating the brake system at full power to ensure more immediate stopping.

ELECTRIC PARKING BRAKE (EPB).

EPB is available on all Maserati cars, and is engaged by simply operating an electrical control on the central tunnel which takes the place of the conventional mechanical lever. In fact, when necessary it can also be used when the car is moving: the system, dialoguing with the stability control (MSP), acts on all four wheels, to obtain immediate braking action (deceleration 0.5 g), in full safety and without any loss of stability, until the control is released.

HILL HOLDER.

To make hill starts easier, the GranTurismo MC Stradale employs the Hill Holder, a device which, on sloping roads, keeps the vehicle braked for a few seconds, so the driver can move his foot from the brake pedal to the throttle pedal without the car rolling backwards.

ADAPTIVE LIGHT SYSTEM.

The GranTurismo MC Stradale's active safety is increased by the adaptive light system which rotates the headlights when cornering to optimise the driver's view of the road ahead.

PASSIVE SAFETY.

The GranTurismo MC Stradale's load bearing frame body, thanks to the innovative technology integrated into its design, greatly increases passive occupant safety. The structural part of the body is made in steel, while the bonnet and bumper front reinforcement cross member are both in aluminium. The weight of the boot lid has been further reduced by using Sheet Moulding Compound technology.

The GranTurismo MC Stradale's airbag system has 4 sensors distributed around the front and sides of the car, and an ECU near the central tunnel. Thanks to the front sensors the front airbags, both dual-stage, always inflate in direct proportion to the severity of the impact. Extensive simulations and testing guarantee that the airbag system complies with the most stringent regulations, and offers unbeatable occupant protection even in extreme situations.

The seat belts are equipped with electronically controlled pyrotechnic pretensioners to ensure optimal operation and close adherence of the belt to the torso in case of collision.

Finally, an inertial switch stops the fuel pumps to prevent fire breaking out in case of violent collision.





Maserati

GT 450 MC

A CUSTOM-MADE MASTERPIECE.

The unmistakable style of Maserati's latest creation is made even more exclusive and personal with a range of details, colours, materials and optional features which make every car absolutely unique: extreme sports or elegance and style, every GranTurismo MC Stradale expresses the personality of its owner.







OPTIONAL EQUIPMENT.

The sporting heritage of the new GranTurismo MC Stradale can be emphasised with optional equipment taken from the world of racing, such as a rollcage (safety cell with rollbar) mounted to the car, available with four point safety harnesses in three colours (blue, black and red) and Alcantara® upholstery. The cockpit can be made even more elegant with an Alcantara® roof lining in combination with carbon fibre detailing.

Externally, the GranTurismo MC Stradale can be clothed in a custom livery with the Maserati trident angled at 45° on the roof (red or grey) or the side panel personalisation kit, consisting of the MC Stradale logo and stripes (in red or grey) applied to both sides to highlight the car's aerodynamic styling.





To further emphasise the link with the Maserati Trofeo and provide the driver with all he or she needs for driving on the track, the car can be equipped with a fire extinguisher behind the front seat and an optional

race kit with its fire retardant competition overalls and homologated gloves in a special bag. To complete the driver's equipment, there is also a race helmet with handmade Maserati graphics.

BODYWORK.

PAINT COLOURS



Bianco Eldorado



Grigio Touring



Nero

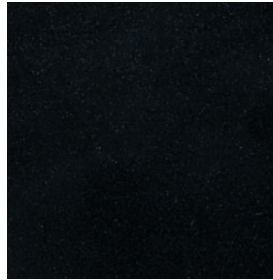

Nero Carbonio



Grigio Granito

SPECIAL PAINT



Giallo Granturismo



Rosso Mondiale



Blu Mediterraneo

MATT COLOURS

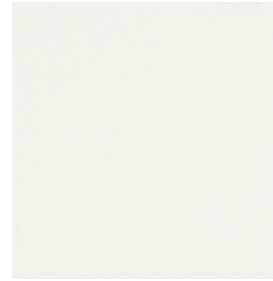

Bianco Fuji

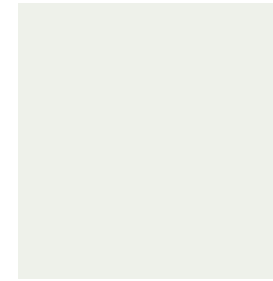

Bianco Fuji



Grigio Granito



Blu Mediterraneo

INTERIOR.

LEATHER COLOURS

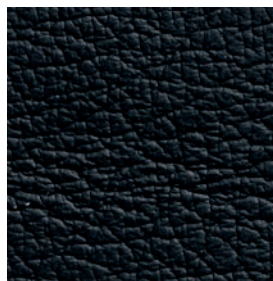

Nero

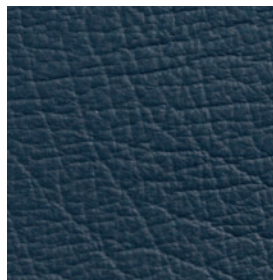

Blu Profondità

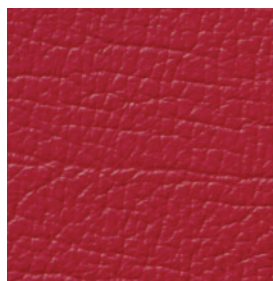

Rosso Corallo

ALCANTARA® COLOURS



Nero

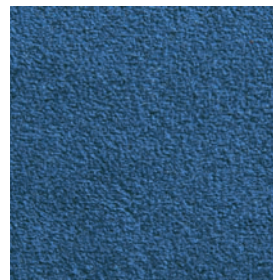

Blu Trofeo

INTERIOR FINISHES

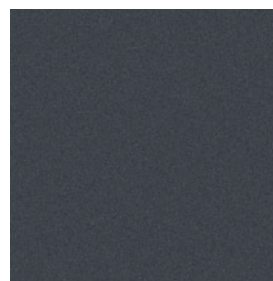

Nero Soft

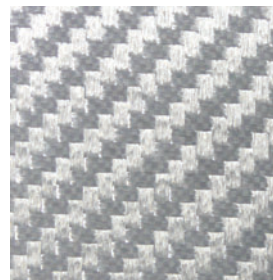

AluTex

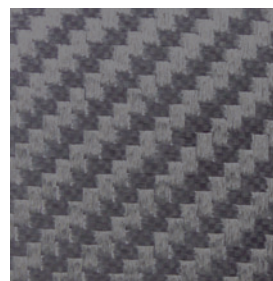

TitanTex



Fibra di Carbonio

WHEELS AND BRAKES.



Brake callipers - painted Titanio
Alloy wheels - 20" MC-Design
Grafite Opaco
(8,5J x 20" front; 10,5J x 20" rear)



Brake callipers - painted Rosso
Alloy wheels - 20" MC-Design
Grafite Opaco
(8,5J x 20" front; 10,5J x 20" rear)



Brake callipers - painted Nero
Alloy wheels - 20" MC-Design
Grafite Opaco
(8,5J x 20" front; 10,5J x 20" rear)



Brake callipers - painted Giallo
Alloy wheels - 20" MC-Design
Grafite Opaco
(8,5J x 20" front; 10,5J x 20" rear)



Brake callipers - painted Titanio
Alloy wheels - 20" MC-Design
Titanio Lucido
(8,5J x 20" front; 10,5J x 20" rear)



Brake callipers - painted Rosso
Alloy wheels - 20" MC-Design
Titanio Lucido
(8,5J x 20" front; 10,5J x 20" rear)



Brake callipers - painted Nero
Alloy wheels - 20" MC-Design
Titanio Lucido
(8,5J x 20" front; 10,5J x 20" rear)



Brake callipers - painted Giallo
Alloy wheels - 20" MC-Design
Titanio Lucido
(8,5J x 20" front; 10,5J x 20" rear)



Brake callipers - painted Titanio
Alloy wheels - 20" Neptune
Nero Lucido
(8,5J x 20" front; 10,5J x 20" rear)



Brake callipers - painted Rosso
Alloy wheels - 20" Neptune
Nero Lucido
(8,5J x 20" front; 10,5J x 20" rear)



Brake callipers - painted Nero
Alloy wheels - 20" Neptune
Nero Lucido
(8,5J x 20" front; 10,5J x 20" rear)



Brake callipers - painted Giallo
Alloy wheels - 20" Neptune
Nero Lucido
(8,5J x 20" front; 10,5J x 20" rear)

STANDARD EQUIPMENT.

20-inch MC-design wheels - shiny Titanium finishing (8.5J x 20" front/10.5J x 20" rear)

Specific high performance tyres

Brake calipers painted Titanium

CCM (Ceramic Composite Material) front 380 mm perforated brake discs with 6-piston calipers; rear 360 mm drilled brake discs, 4-piston calipers

Double wishbone single damping suspension with stiffer set-up and high lowered ride

Shadow line (door handles in body colour and window mouldings in black)

Dual powered/heated exterior mirrors

Sport exhaust - central positioned dual tail pipes, in chrome plated stainless steel, pneumatic valves controlled via "SPORT/RACE" buttons

Front grille with vertical grille bars in black colour, trident with red accents; lateral port hole grilles

Front spoiler integrated with aerodynamic undertray and brake system cooling air ducts

Front hood with double air-outlets on the side

Lightweight boot lid construction, with remote key unlocking

Additional lip spoiler in deck lid

Headlights - Black background, white side marker reflector

Taillamps with LED technology

Folding front armrest with illuminated storage compartment

Central cushion on the rear bulkhead with stitched Trident logo

Bucket seats in carbon fiber

Nero Soft interior trim

Maserati "Active Shifting" shift paddles (Trofeo design)

Aluminium sport pedals

Maserati clock design in central dashboard with chrome-plated trim

Fabric headliner

Smoker package

Three-spoke multifunction sport steering wheel

Trident logo stitched on head restraints

Two individual front full size cup-holders

Poltrona Frau leather/Alcantara upholstery (including Alcantara/black leather steering wheel)

Alarm system (perimeter and volumetric sensing, anti-lift device, electronic immobilizer)

Automatic headlamp activation

Cruise control

Dual zone automatic climate control

Electric opening assist for boot lid and doors

Electronic Parking Brake (EPB)

Rear parking sensors

Maserati Hi-Fi sound system

Maserati Multi Media System with 7" in dashboard screen (navigation system, RDS tuner, single CD player, 30 GB hard disc drive, voice control, bluetooth, USB and AUX-IN)

Power-assisted steering, with speed sensitive feature

Rain sensor

Remote key (on/off alarm system, lock/unlock doors, unlock boot lid)

MC-design sport instrument cluster

Digital RPM indicator

SPORT and RACE buttons for sport mode set up (manual gearshift, accelerator, MSP system, exhaust system, instrument display). MC-R gearshift available in RACE mode.

Tyre sealing compound and electric air compressor

Air-bag system (front bags and window bags)

Bi-xenon headlights with headlights washing system

Front seat belts with pre-tensioners

Maserati Stability Program

Adaptative light control system

Steering wheel with manual height and reach adjustments

Automatically dimming rearview interior mirror

OPTIONAL.

WHEELS AND CHASSIS

20-inch MC-design wheels - matt Grafite finishing (8.5J x 20" front/10.5J x 20" rear)

Brake calipers painted Black

Brake calipers painted Yellow

Brake calipers painted Red

Space saver spare wheel

EXTERIOR

Metallic paint

Special paint

Pearlescent paint

Special matt paint

Car cover

Track-day driver kit (omologated fireproof suite and gloves, bag)

INTERIOR

Alcantara headlining (Grigio, Nero, Blu Trofeo)

"AluTex" trim on selected interior details

"TitanTex" trim on selected interior details

Colour upon request for steering wheel leather details (including central gear pod)

Steering wheel and gear pod in black leather

Steering wheel and gear pod in coloured leather

Steering wheel in composite fibre (AluTex, TitanTex) trim and black leather (including gear pod)

Stitching colour upon request (steering wheel excluded)

Upper/lower dashboard and rear shelf colour upon request

Carpet piping colour upon request

Front floor mats

Door entry guards in composite fibre (AluTex, TitanTex)

Rollbar and 4 point seatbelt

Handy fire extinguisher

COMFORT AND FUNCTIONALITY

Automatically dimming exterior mirrors

HomeLink - Garage door opener

AUX-IN connection

Ipod connection

MC SPORT LINE

Aerodynamic package in carbon fiber (rear lip spoiler in carbon fiber, side mirrors in carbon fiber, doors handles in carbon finish)

Interior carbon package (carbon finish on dash and door panels trim strips, upper door trim strip in carbon fiber)

Interior carbon package - evolution I (door entry guards in carbon fiber with "MC Stradale" logo, centre console in carbon fiber)

Interior carbon package - evolution II (paddles shift in carbon fibre, instrument surround in carbon fiber)

Electro-actuated switch controls in carbon fiber

Steering wheel in carbon finish and black leather

MC design Aluminum driving pedals (incl. dead pedal)

20-inch Glossy Black Neptune-design alloy wheel (8,5J x 20" front/10,5J x 20" rear)

MC Stradale exterior livery (trident on the roof and stripes on the sides)

Exterior livery on the roof (trident)

Antireflection band with Maserati logo

TECHNICAL SPECIFICATIONS.

DIMENSIONS AND WEIGHTS

Length	4.933 mm
Width	1.915 mm
Height	1.343 mm
Wheelbase	2.942 mm
Front track	1.586 mm
Rear track	1.590 mm
Front overhang	925 mm
Rear overhang	1.066 mm
Turning circle	10,5 m
Boot capacity	320 l
Fuel tank capacity	90 l
Dry weight	1.670 kg
Kerb weight	1.770 kg

TYRES

Front	255/35 ZR 20
Rear	295/35 ZR 20

ENGINE

Number of cylinders and layout	V8
Displacement	4.691 cc
Bore	94 mm
Stroke	84,5 mm
Compression ratio	1 : 11
Max. power output	330 kW
Engine speed at max. power output	7.000 rpm
Peak torque	510 Nm
Engine speed at peak torque	4.750 rpm

PERFORMANCE

Maximum speed	301 km/h
0 to 100 km/h acceleration	4,6 s
Fuel consumption (combined cycle)	14,4 l/100 km
CO ₂ emissions (combined cycle)	337 (g/km)
Fuel consumption (urban cycle)	22,7 (l/100 km)
Fuel consumption (extraurban cycle)	9,7 (l/100 km)

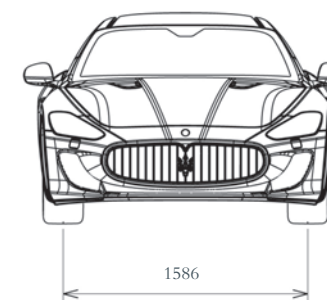
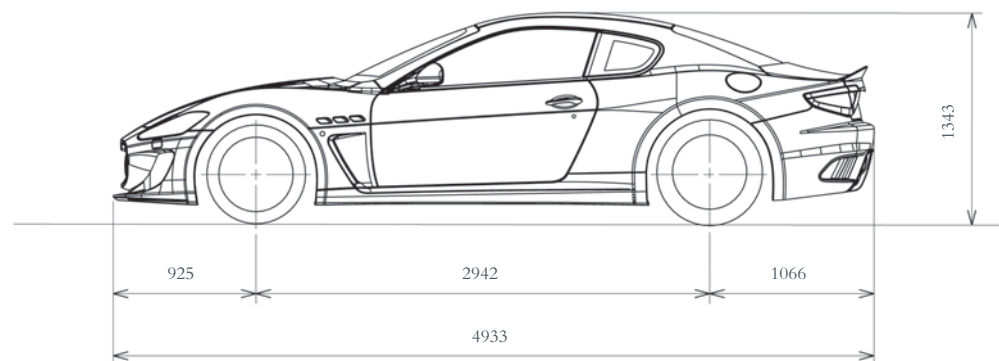
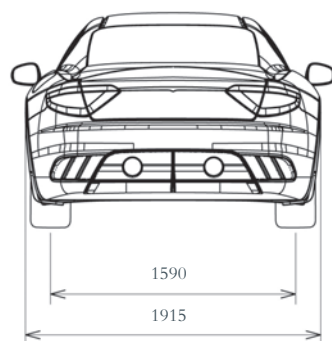

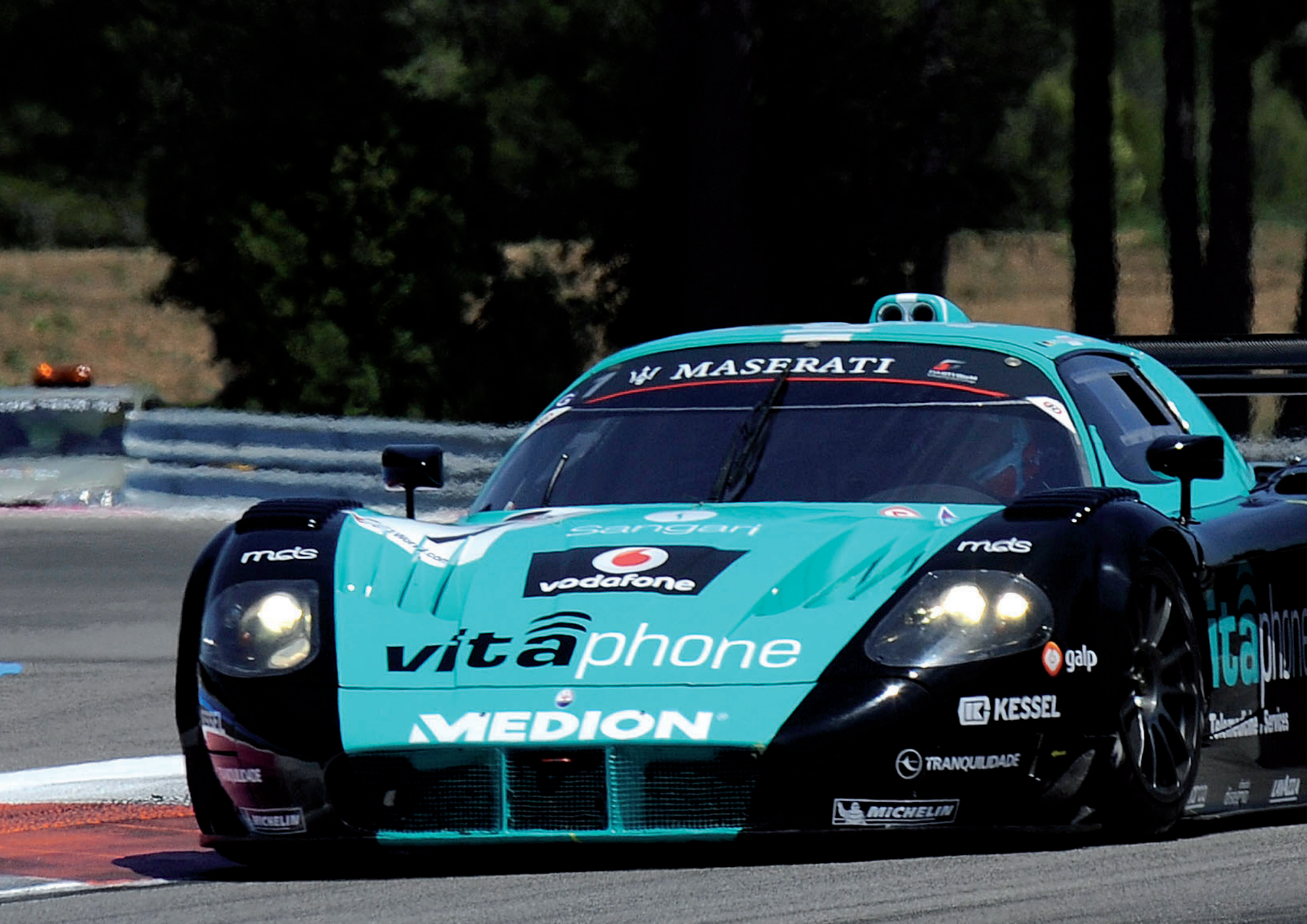

MASERATI

Sangari

vodafone

vitaphone

MEDION

mcs

mcs

galp

KESSEL

TRANQUILIDADE

MICHELIN

vitaphone
Telecomunicacões e Serviços



THE WORLD OF MASERATI.

A world of competition, passion and services dedicated to those who love Maserati.



MASERATI CORSE.

Racing has always been the most demanding test-bed; used to put engineering developments through their paces. Traditionally, reliability and performance are tested on the track, and it is where new technologies and materials are tried out. It is also through racing that Maserati celebrates its sporting character and heritage.

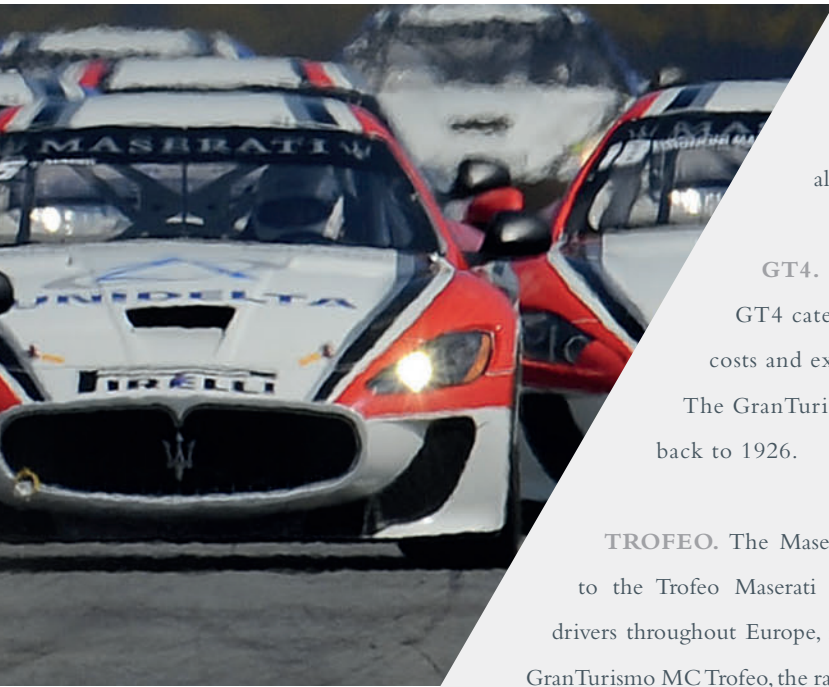

GT1. The new FIA GT1 World Championship, an evolution of the FIA GT, is where the Maserati MC12 cars will once again attempt to confirm their supremacy in GT competitions. This car has won 12 championship titles (drivers, teams and manufacturers) since 2004, and also successfully competed in the prestigious and gruelling Spa 24 Hours.

GT4. The GranTurismo MC GT4 has been developed by Maserati for the new GT4 category, which is an increasingly popular formula thanks to the relatively modest costs and excellent support organisation.

The GranTurismo MC GT4 is a continuation of Maserati's racing heritage, which dates back to 1926.

TROFEO. The Maserati Championship is once again the star of the race circuit thanks to the Trofeo Maserati GranTurismo MC; an eight-races championship for gentleman drivers throughout Europe, run alongside the World Touring Car Championship. Using the GranTurismo MC Trofeo, the racing version of the GranTurismo S 4.7, participants can contest the championship with all the cars prepared to an equal standard and managed directly by Maserati Corse. In addition, private teams can purchase a GranTurismo MC GT4 to compete in a separate class distinct from the Trofeo cars.

For information email: trofeomaserati@maserati.com

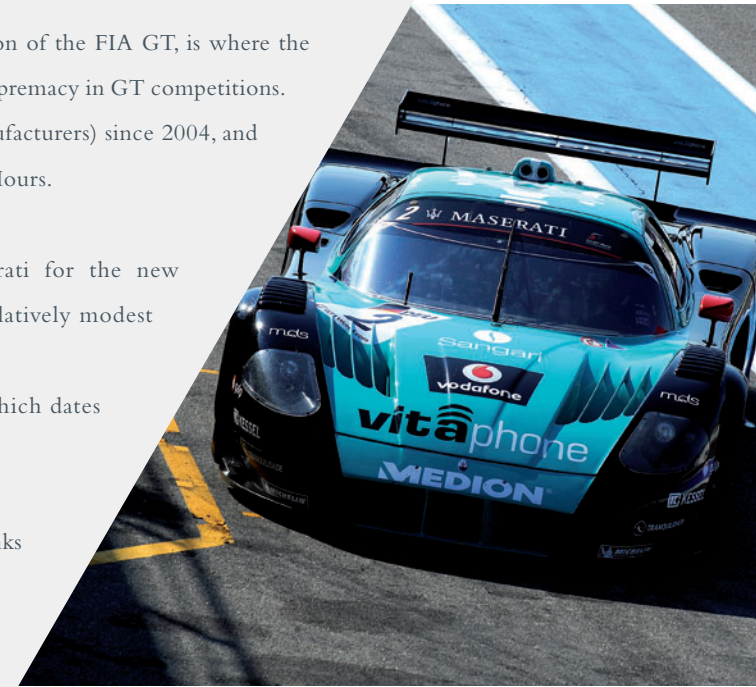



MASTER MASERATI DRIVING COURSES.

It is perhaps the ultimate driving experience: taking to the racetrack in a race-tuned Maserati. A Master Maserati Driving Course places you behind the wheel of various different Maserati models, so that you can learn about performance driving and other techniques that will enable you to fully appreciate your own Maserati's performance, and improve your driving skills.

The courses take place at the Varano de' Melegari Circuit, near Parma - a demanding circuit that puts even the best drivers to the test. It is fully equipped with the latest driving instruction equipment, and the courses are run by ex-Formula 1 driver, Ivan Capelli, who is ably assisted by a highly experienced team of professional instructor-drivers.



MASTER GT. An all-inclusive two-day course, spent at the wheel of various different Maseratis. It is an intensive training programme that comprises a number of exciting and dynamic sessions, including cornering trajectory technique, acquisition and analysis of Formula One type telemetry data, and driving with a pace-car. In addition, you are taught how to control the car in different simulated road conditions, e.g. quick direction changes, skid situations, and various braking techniques.

MASTER HIGH PERFORMANCE. The Master HP Maserati represents a further evolution of driving technique concepts developed during the previous GT program. The course, designed to offer a highly professional and technically advanced service, provides the unique opportunity to master the world of Maserati GranTurismo, testing high performance Maserati models on the Varano de' Melegari track, through a highly personalised and specialised program that combines driver satisfaction and technique.

MASTER MC TROFEO. The Master Maserati MC Trofeo is the ultimate expression of the sports driving concepts developed in the previous High Performance programme.

The course, an unforgettable and thrilling experience with a highly professional and technically evolved programme, gives you the once-in-a-lifetime chance to be part of the Maserati competition world, and drive the cars competing in the Trofeo Championship on the Varano de' Melegari circuit.

For information and registration: Master Maserati Office,
Tel.: +39 0525 55 11 38 - Fax: +39 0525 55 11 40 - info@mastergt.it - www.maserati.com



INDIVIDUAL TESTING.

Following an intensive testing programme and minute examination within the factory, each new Maserati GranTurismo is put through its paces by professional Maserati drivers in a thorough, 50 kilometre test drive on challenging roads.

FACTORY DELIVERY.

Taking delivery of a Maserati GranTurismo should be a unique and special occasion. To this end, the company offers its customers the opportunity of collecting their car themselves from the Maserati works in Modena. A tour of the production line, and formal handover in the stunning, Ron Arad-designed showroom make the customer's introduction to Maserati ownership a truly unforgettable event.

**THREE YEAR WARRANTY
AND ROADSIDE ASSISTANCE SERVICE.**

The Maserati Assistance Service is provided free of charge for 3 years (with unlimited mileage) and comprises an exclusive package of services in addition to the standard warranty cover.

The services included are roadside assistance, replacement car, taxi for collection and return of replacement car, homeward or outward travel for passengers, collection of the repaired vehicle, hotel cost, repatriation of the vehicle to be repaired from abroad, money advance for essentials, motoring information (in Italy only) and information about the official Maserati authorised dealership network. These services are provided through the relative Assistance Centres, operating 24 hours a day, 365 days a year.

MASERATI EXTENDED WARRANTY.*

All Maserati GranTurismo, Quattroporte, Coupé, Spyder, GranSport and GranSport Spyder owners can extend their vehicle's standard warranty for further 12 or 24 months unlimited mileage warranty. So they can drive their car for 5 years with peace of mind.

The Extended Warranty can be activated before the standard warranty expiry date provided that the mileage does not exceed 100,000 km. For details of the Maserati Extended Warranty programme, please contact your nearest Maserati dealer.



**MASERATI
CERTIFIED PRE-OWNED**

MASERATI CERTIFIED PRE-OWNED.

“Maserati Certified Pre-Owned” is the exclusive programme that provides an unlimited mileage, 12 or 24 month warranty for the best pre-owned Maserati vehicles.

To benefit from this programme a pre-owned Maserati has to pass 120 strict technical checks. With this certification, each car complies with the highest quality standards and is able to satisfy even the most detail-conscious client. The client can simply focus on the pleasure and thrill of driving their own Maserati.

*in the case of extension for the 5th year, the warranty must be extended by the end of the 4th year warranty extension.

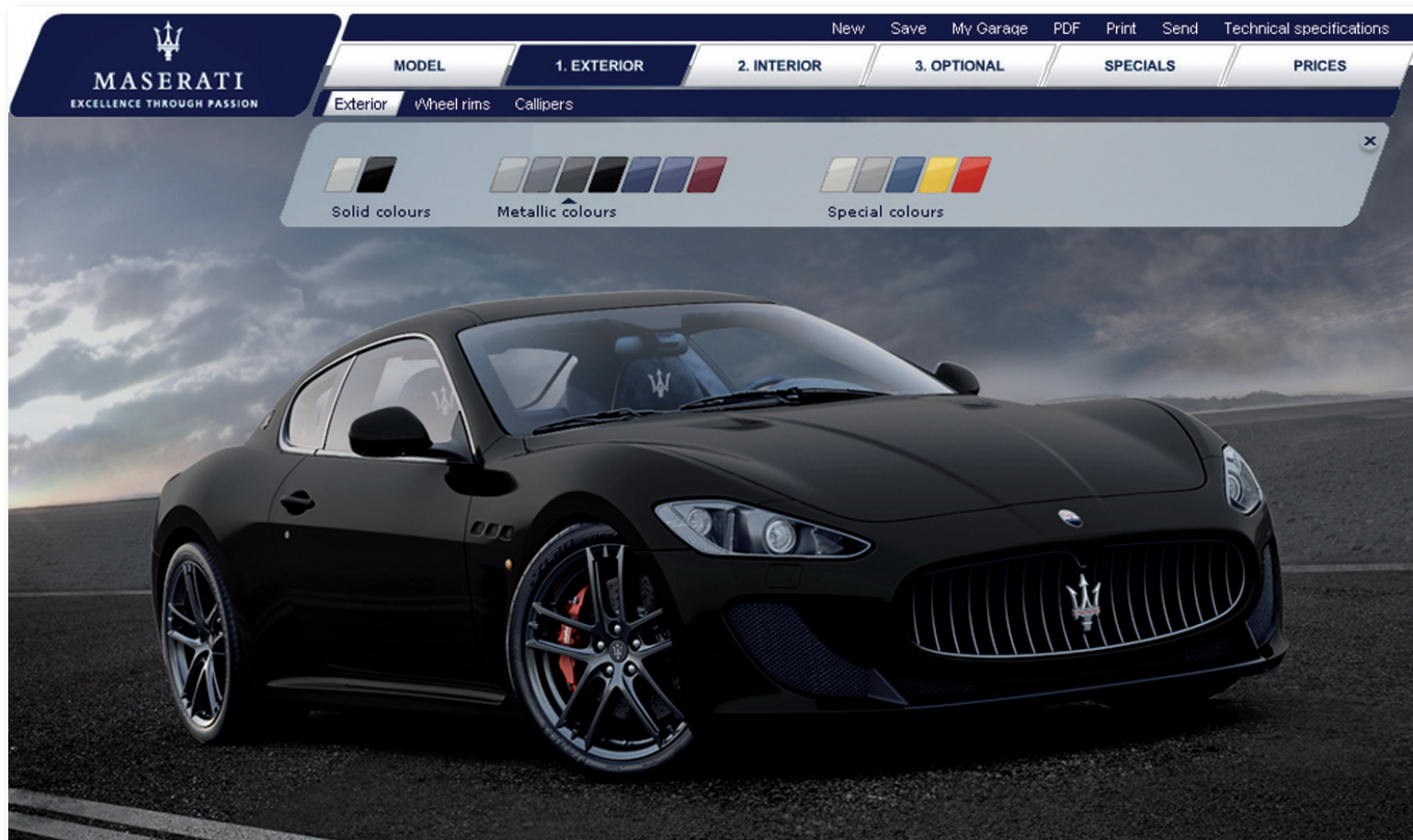

MASERATI WEBSITE AND CAR CONFIGURATOR.

Recently redesigned, the www.maserati.com web site lets users browse the Maserati world at ease, view multimedia content or historical information, search the official Maserati dealer network for pre-owned Maserati cars, and create their very own car with the state-of-the-art car configurator. Due to the huge number of ways in which the Maserati cars can be per-

sonalised, Maserati has developed a very special configuration website: www.configurator.maserati.com. Visitors to this site can configure their chosen model, and then view every mechanical detail inside thanks to its innovative 'X-Ray' viewing facility.

Create your Maserati on www.configurator.maserati.com

FACTORY TOUR.*

For the ardent Maserati enthusiast who wants to discover more about the marque and how the cars are designed and built, a factory tour of the Modena plant can be arranged.

THE MASERATI EXPERIENCE.**

For those wishing to combine their factory visit with a little more insight into the company's home city of Modena, Maserati has the perfect solution. Lasting either one or two days, the Maserati Experience enables you to get to know the world of Maserati at first-hand via a guided tour that allows you to discover Modena, its culture, its history and its fine food.

You can tailor your Maserati Experience to your own personal tastes and interests by combining a variety of activities:

- Visit to the Panini Museum and/or Stanguellini Museum (famous motor museums)
- Guided tour of the town
- Guided tour of a traditional balsamic vinegar manufacturer, with tasting
- Guided tour of a winery, with tasting of local wines
- Cookery school
- Day at the Modena Golf & Country Club

... and much, much more.

* Tours are by appointment only, and can be arranged through Maserati dealerships.

** For more information please contact us at maseratiexperience@maserati.com.





THE MASERATI COLLECTION.

The Maserati Collection of quality leisurewear, goods and branded merchandise has been specially created for those who share the Maserati passion, and who seek to associate with the illustrious marque.

Maserati Collection items are available from all Maserati Dealers and from the Maserati Store at the Maserati showroom in Modena.

Alternatively all the articles in the collection can be purchased online at www.maseratistore.com and shipped directly to your home.



MASERATI CLUB.

Joining the exclusive Maserati Club means sharing thrills and experiences with other Maserati owners, and being invited to take part in special motoring events all over the world. Drivers with cars from every era can enjoy the pleasure of driving their Maseratis in a calendar of events constructed exclusively for Maserati Club members. The Maserati Club provides the link between the past, present and future of the company. It is run by individuals who have made a major contribution to the growth and promotion of Maserati across the decades, starting with the President, Maria Teresa de Filippis, the first ever female Formula 1 driver.

For more information, access www.maseraticlub.com

ORIGINAL MASERATI ACCESSORIES.

Especially designed to address widely different needs original Maserati accessories represent the perfect combination of design and functionality, complete with a guarantee of the highest quality, a characteristic that has always been associated with our brand. The range of original accessories includes ad hoc items designed to enhance the elegance and sporty appeal of Maserati models. Exterior variations, for example, coloured front grilles or brake callipers; interior finishings, such as carpet overlay kits and under-door moulding covers; components associated with dynamic performance with a wide choice of alloy rims and spoilers; car care accessories such as car covers, leather care kits, battery chargers and satellite anti-theft system: these are just some of the many items available.

SERVICES.

NORTH AMERICA

Canada
USA

CENTRAL / SOUTH AMERICA

Argentina
Brasil
Chile
Colombia
Costarica
Dominican Republic
El Salvador
Guatemala
Mexico
Panama
Puerto Rico
Venezuela

EUROPE

Austria
Belgium
Bulgaria
Cyprus*
Czech Republic
Denmark
Finland
France
Germany
Great Britain
Greece
Holland
Hungary
Italy
Latvia
Luxemburg
Montecarlo
Norway*

Portugal
Romania
Russia
Slovenia
Spain
Sweden
Switzerland
Turkey
Ukraine

ASIA / OCEANIA

Australia
China
Hong Kong
Indonesia
Japan
Korea
Malaysia
New Zealand
Philippines
Singapore
Taiwan
Thailand

AFRICA / MIDDLE EAST

Egypt
Bahrain
Kuwait
Lebanon
Oman
Qatar
Saudi Arabia
South Africa
U.A.E.

*Service only





MASERATI CONTACT CENTRE:

Italy - 800 008 008 • Switzerland (German) - 0800 837 100 • Switzerland (French) - 0800 837 200 • Switzerland (Italian) - 0800 837 300 • Germany - 0800 810 80 80 • Sweden - 020 798 000 • Norway - 800 180 88 • Finland - 0800 110 808 • Austria - 0800 281 888 • France - 0800 908 000 • Monaco - 800 93 888 • Denmark - 80 888 000 • Belgium (Flemish) - 0800 710 31 • Belgium (French) - 0800 710 30 • Luxembourg - 8002 8000 • Holland - 0800 0 224 234 • Spain - 9009 969 45 • Portugal - 8008 39 103 • Greece - 00800 3912 725 41 • Turkey - 00800 399 090 538 • United Kingdom - 0800 064 6468 • Latvia - 0371 7500 100

INTERNET: www.maserati.com



M *Stradale*

The illustrations and texts contained in this brochure are based on the information available at the time of production and do not contain a description of specific characteristics of the car by the Constructor. Some models, equipment and accessories may not be available or may only become available after the car's launch on the market. Maserati reserves the right to modify colours, designs and technical features at any time and without forewarning. Official Maserati Dealers will be glad to provide further details and updates in this regard.

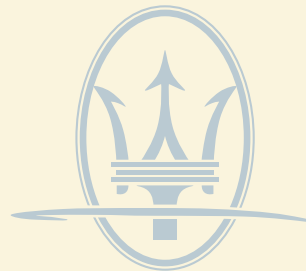

WWW.MASERATI.COM

WWW.MASERATIGRANTURISMOMCSTRADALE.COM

MASERATI SPA · VIALE CIRO MENOTTI, 322 · 41121 MODENA · ITALIA