

Saab 9000

1994



SAAB

Saab 9000. For those who judge achievement by performance.

The Saab 9000 is a very particular kind of car. It's not a car for people who measure status by the yard.

Saab 9000 owners have discerning tastes and opinions, and they're not

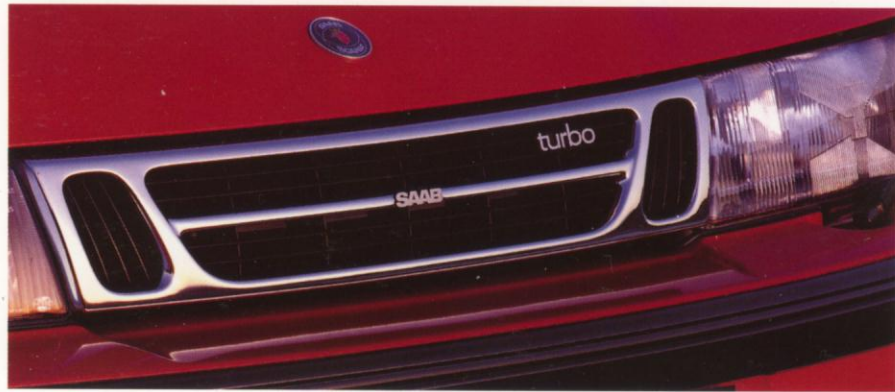

afraid to exercise them. We recognise this by offering the Saab 9000 in two body styles. The sleek and sporty 9000 CS, CSE and Aero. The elegant and refined 9000 CD, CDE and Griffin. Each gives its owner considerable driving pleasure, enhanced by the knowledge that the Saab 9000 is among the most environmentally friendly cars in its class.

Indulge your taste for the dynamic. Saab 9000 Aero.

The Saab 9000 Aero has the power to transport you to a new level of control and driving excitement. A chassis which communicates every nuance of the road. A degree of comfort that makes even the longest journey feel too short. It has an unconventional and unique approach to design and engineering.

An individual style which balances excitement with a sense of responsibility. Our concern for your safety and everyone's environment is something that has always been a Saab characteristic.

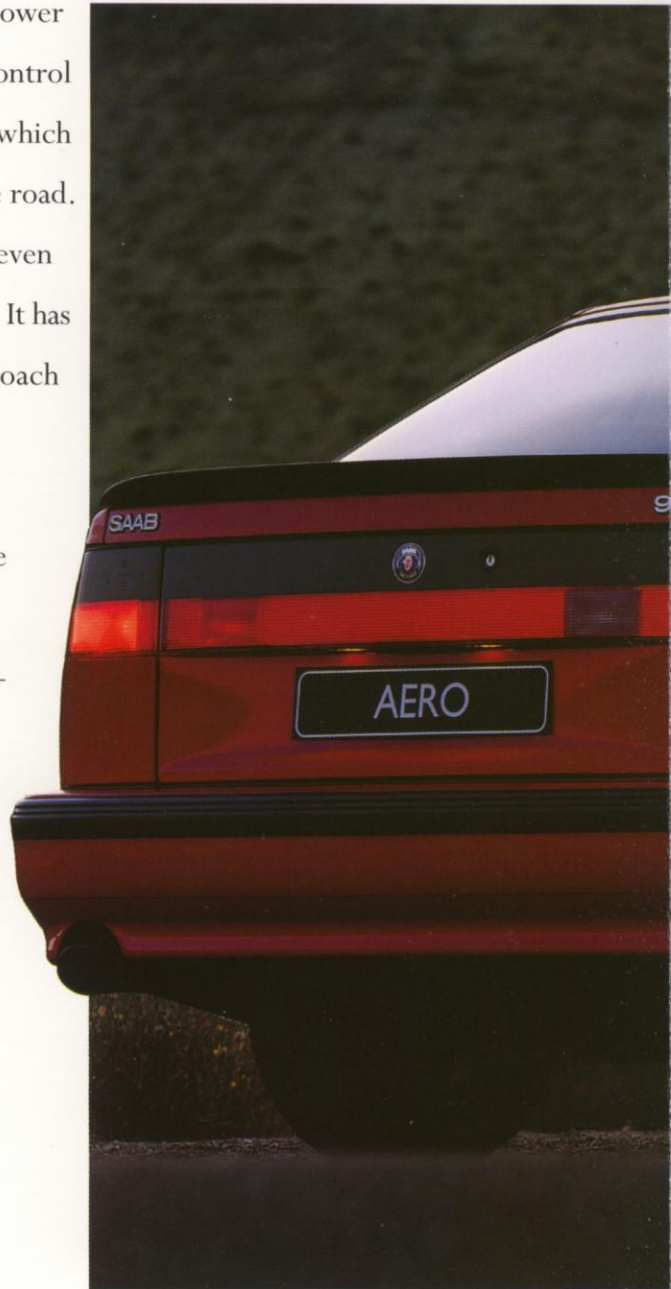

Contents:

Saab 9000 Aero.....	3
Saab 9000 CS/CSE.....	8
Saab 9000 Griffin.....	10
Saab 9000 CD/CDE.....	12
Saab 9000.....	14
Driver's environment.....	16
Product features.....	18
Engines.....	20
Saab Trionic.....	22
Safety.....	24
Comfort and flexibility.....	28
Options and accessories.....	30
Technical data.....	32
Equipment.....	34
Upholstery and colours.....	36



We lift the restrictions on space as well as distance.

With space as well as distance, the road ahead is yours. The road ahead is yours.

Drive the road ahead with the excitement and environmentally friendly traditions of Saab.



Prototype Saab, ready to drive in 1946.

We lift the restrictions on space as well as distance.

For Saab, comfort is not just luxury, it's a matter of safety. When you cover a lot of distance in a car, space and ergonomics become very important. According to America's EPA, the Saab 9000's interior space makes it a "large car". This space has allowed us to give the Saab 9000 a Business Class standard of equipment. Controls for all functions are logically grouped, always well within reach.



The leather used in the upholstery of our seats is hand-selected for appearance and feel.



Electrically powered front seats with programmable memory on the driver's side.



Nothing so functional was ever this
exciting.

Leather interior of the Saab 9000 Aero
with special seats and upholstery with
semi-aniline inserts to keep you cool on
even the hottest days.



Nothing so functional was ever this exciting. Saab 9000 CS and CSE.

Enjoy the exceptional comfort and safety of the Saab 9000, one of the most spacious cars on the road today.



You only have to sit in a Saab 9000 CS or CSE to see it's a car that will pamper you. The level of indulgence simply depends on each driver's individual taste and requirements.

Saab 9000 CS and CSE. Each offers a high degree of comfort and equipment. Saab Trionic, one of the most advanced engine management systems, controls every Saab 9000

Purity of form and freedom of movement.
The 9000 Griffin is a classic Saab.

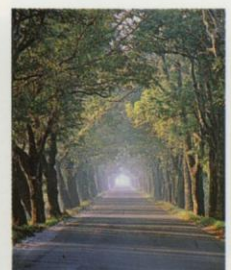

Driving with
respect for nature.

engine from the 2.0i to the 2.3 turbo
and new 2.3 Ecopower.

Standard ABS complements their
power with security. The Saab 9000
offers comfort and performance in a

car of great presence, and distinction.



Purity of form and freedom of movement. The 9000 Griffin is a classic Saab.



Our new heat-absorbing glass absorbs 50% of radiated heat, keeping the interior cooler.



A classic understated saloon needn't be part of the common herd. The Saab 9000 Griffin is the natural choice for those who want individuality without ostentation. What makes it a typical Saab

is the spacious interior and high levels of comfort it offers.

The Saab 9000 Griffin affords a level of opulence and equipment that is hard to match. Indulgent touches like wool

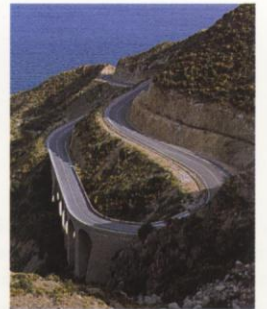

The decision for a Saab 9000 is not so much for a car, but rather against convention.

or leather upholstery (optional) with wood veneer fascia and door cappings. Automatic Climate Control (ACC) that allows you to select the exact temperature you prefer. The Saab Car Computer (SCC)

allows you to plan your journeys more efficiently.



Our past pointed out the road ahead.



To demonstrate the durability of the Saab 9000 Turbo, a non-stop test known as "The Long Run" was held in 1986 on the world's fastest race track in Talladega, USA. The outcome was 21 new international records.

The 9000 CD and CDE follow a long line of Saabs whose design made them ideal long distance tourers.

Safety is another Saab tradition, and standard ABS is just part of both models' safety equipment. Their engines, all with

our Trionic engine management system, help preserve the future by meeting the toughest environmental standards.

You can't shorten the distance, but
you can enhance the comfort.



The Saab 9000 is more than the sum of its parts. It is exceptional and distinctive, representing a truly unique way of living and driving.



You can't shorten the distance, but you can enhance the comfort.



Saab's unique electrostatic ventilation filter which traps particles as small as 0,004 mm makes any Saab a safer haven for anyone with an allergy.



The roomy interior of the Saab can be enhanced with the luxury of genuine leather.

The Saab 9000 pampers its owner with an interior in which every conceivable feature has been provided. However there is another indulgence

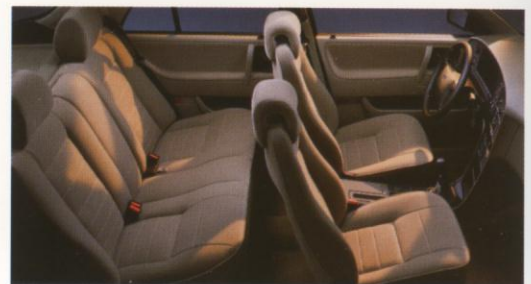

High-quality velour upholstery accents the Saab's interior.

The controlled application of power.



which is just as important: space. The space that ensures true comfort. Comfort that seems to shorten journeys and makes long-distance driving a pleasure.



Reading lamps allow the rear passengers to read, but don't distract the driver.



The controlled application of power.

you can enhance the comfort.



A swivelling spotlight is ideally placed for map reading.



The design of the fascia follows the driver's natural reach.

This is the command centre of a Saab 9000. Where the controls are grouped logically and so fall to hand naturally. Where you have everything at your command and your preferred operating temperature can be maintained by Automatic Climate Control (ACC) which uses a Saab-pioneered CFC-free cooling agent R134a. Where your safety is enhanced by a standard driver's-side airbag (passenger's side is optional).

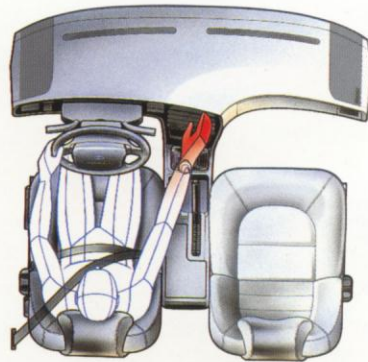

Saab 9000 CS.

Application of power.
Comfort, safety and performance
in perfect harmony.

CFC-free air conditioning
with electrostatic air filter

Electrically adjustable
and heated door mirrors

The Saab 9000, here the CS model, is characterised by its technical refinement, its generous space and all the typical Saab details which put driving pleasure and safety at the forefront. (Standard and optional equipment vary from market to market. Passenger's airbag not available with right-hand drive.)

Transversely-mounted engine with Saab Trionic engine management system

Saab Direct Ignition with one ignition coil per cylinder

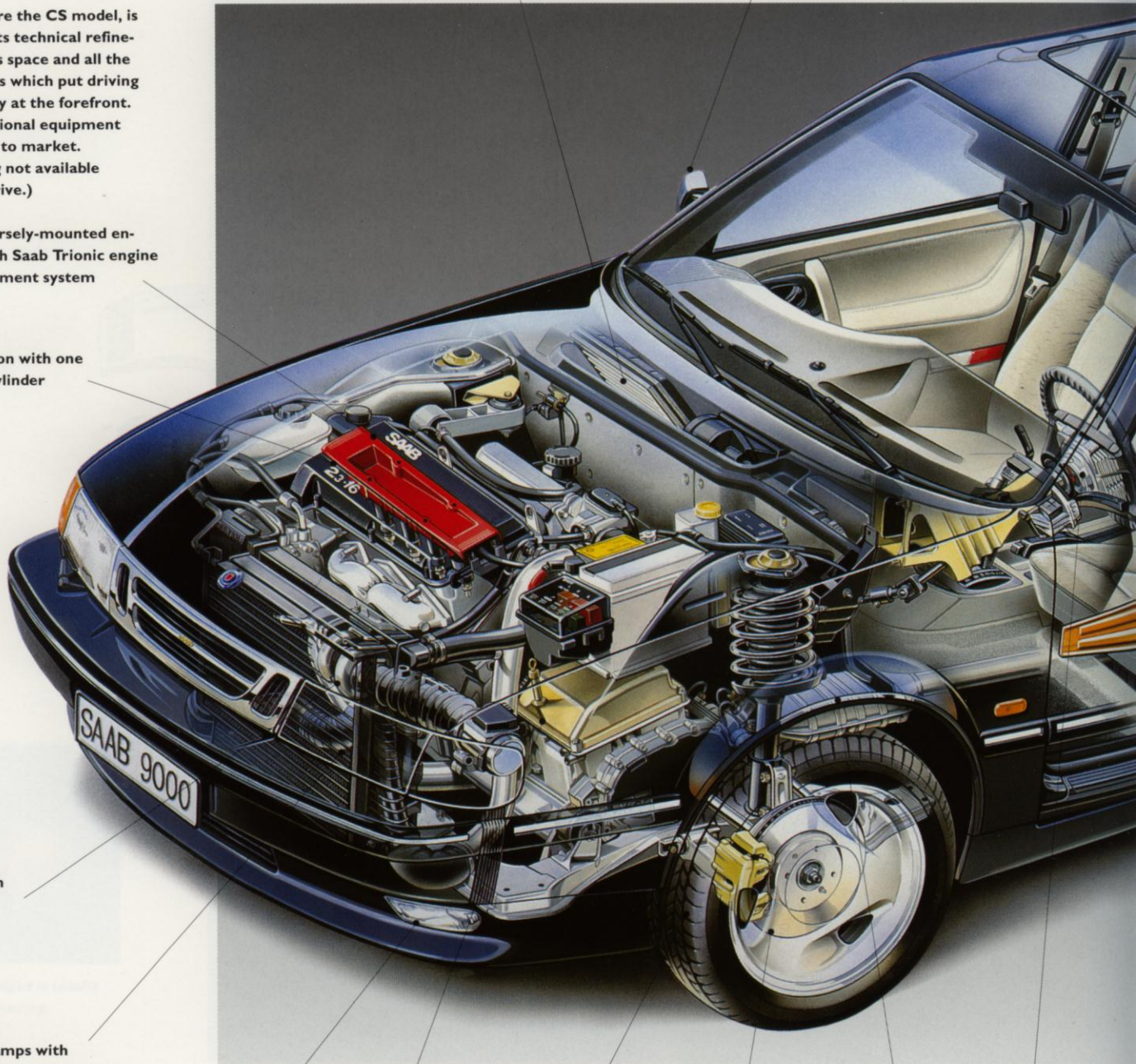

Turbocharger with intercooler

Twin headlamps with separate reflectors for main beam and dipped beam

Computer designed fog-lamps

4-speed automatic transmission

Front-wheel drive

ABS anti-lock brakes

Climate-related catalytic exhaust emission control

Dual airbags (optional for passenger)

Insiders are the first to recognize the forces behind performance.

Defroster outlets for rear side windows

Asymmetrically-split folding rear seat

Heat-absorbing glass all round

Rigid safety body for high levels of motoring comfort and excellent roadholding



Flat luggage compartment floor with low sill

Sturdy, protective steel members in the doors

Electrically adjustable front seats with memory function for driver's seat

Automatic front seat belt tensioner

Side-collision protection is enhanced by reinforced side pillars and door sills

Insiders are the first to recognise the forces behind performance.

in perfect harmony.

The 2.3 turbo's high torque of 342 Nm means the Saab 9000 can accelerate from 60 to 100 km/h in fourth gear in just 6.5 seconds.

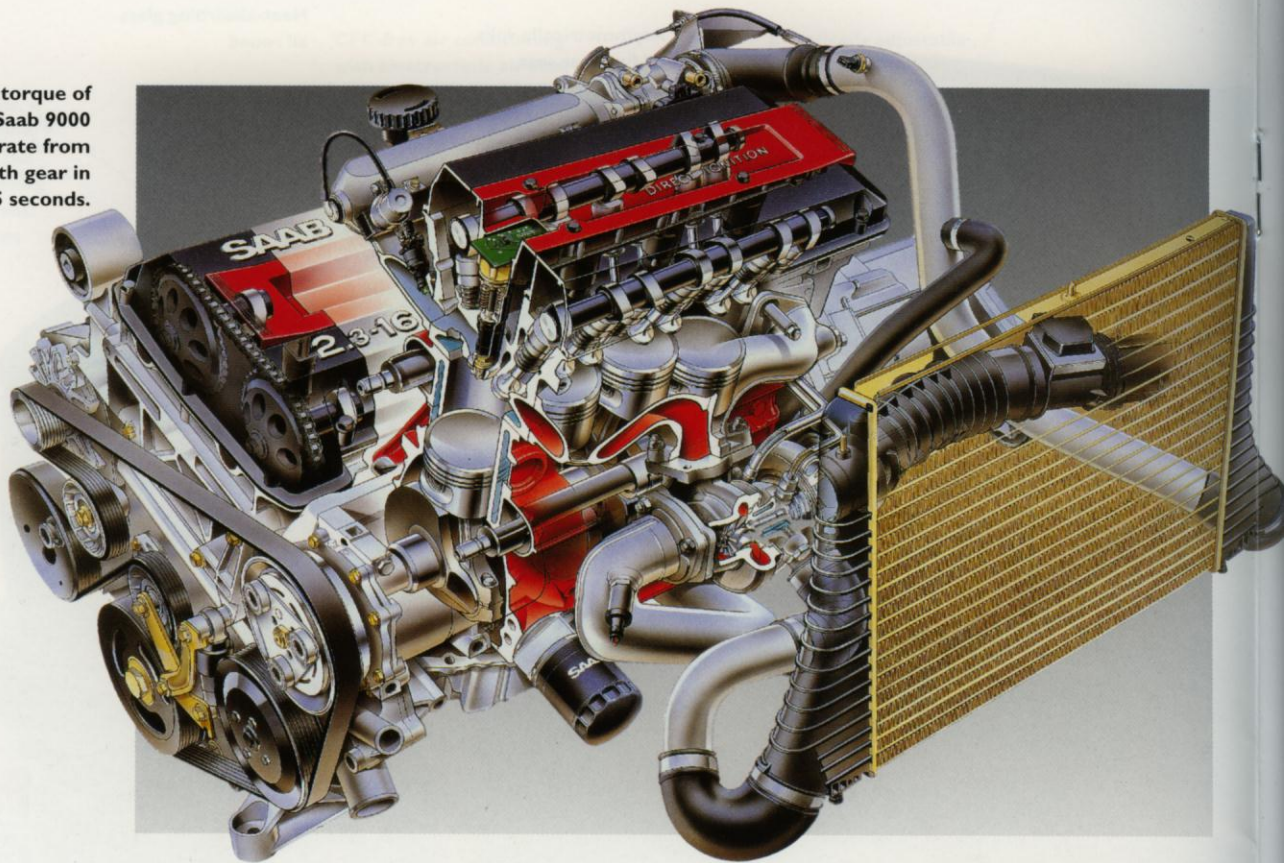

Saab has always aimed to design light, compact highly efficient engines. A powerful engine need not be large and heavy. In fact, it's a disadvantage.

THE SAAB TURBOS.

Saab was the first major manufacturer to use turbocharging and four-valve technology for everyday cars. Our turbo

engines are designed to boost torque right across the engines rev range. To give useful power for real-life situations like overtaking.

Four-valve technology makes the engine very efficient and clean.

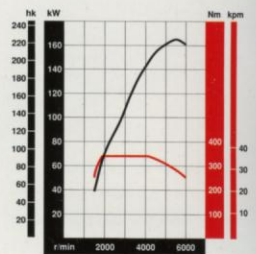

Saab engines have high torque even at low speed so fast overtaking is possible without changing gear.

A four-valve engine burns fuel more thoroughly, improving economy and emission levels.

Our unique Direct Ignition gives each cylinder its own coil. This improves starting, and as our DI system has no moving parts it is

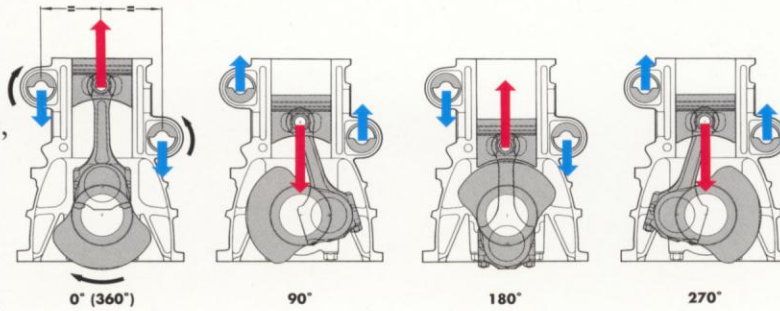

more reliable with lower service costs.

In addition to our normal turbos, the Ecopower light pressure turbo is an engine designed to balance a good spread of power with very low emission and noise levels. The Ecopower engine is now available as a 2.3 litre as well as a 2.0 litre engine.

NORMALLY ASPIRATED ENGINES.
The 2.3i and 2.0i fuel-injected engines are economical and compact four-cylinder engines. Thanks to Saab's Trionic engine

management system and 16-valve technology they also boast very low emissions.

The 2.0i and 2.0 turbo now also have integrated balancer shafts to eliminate vibration. Right through the rev range they act to make this powerful 4-cylinder engine one of the world's smoothest.



The new 5-speed manual gearbox has better synchromesh to reduce effort when changing gears.

Saab Trionic. A working example of the perfect balance of power and responsibility.



In 1991 this award from Germany's respected medical journal STATUS recognised the Saab 9000 as the most environmentally friendly car in its class.

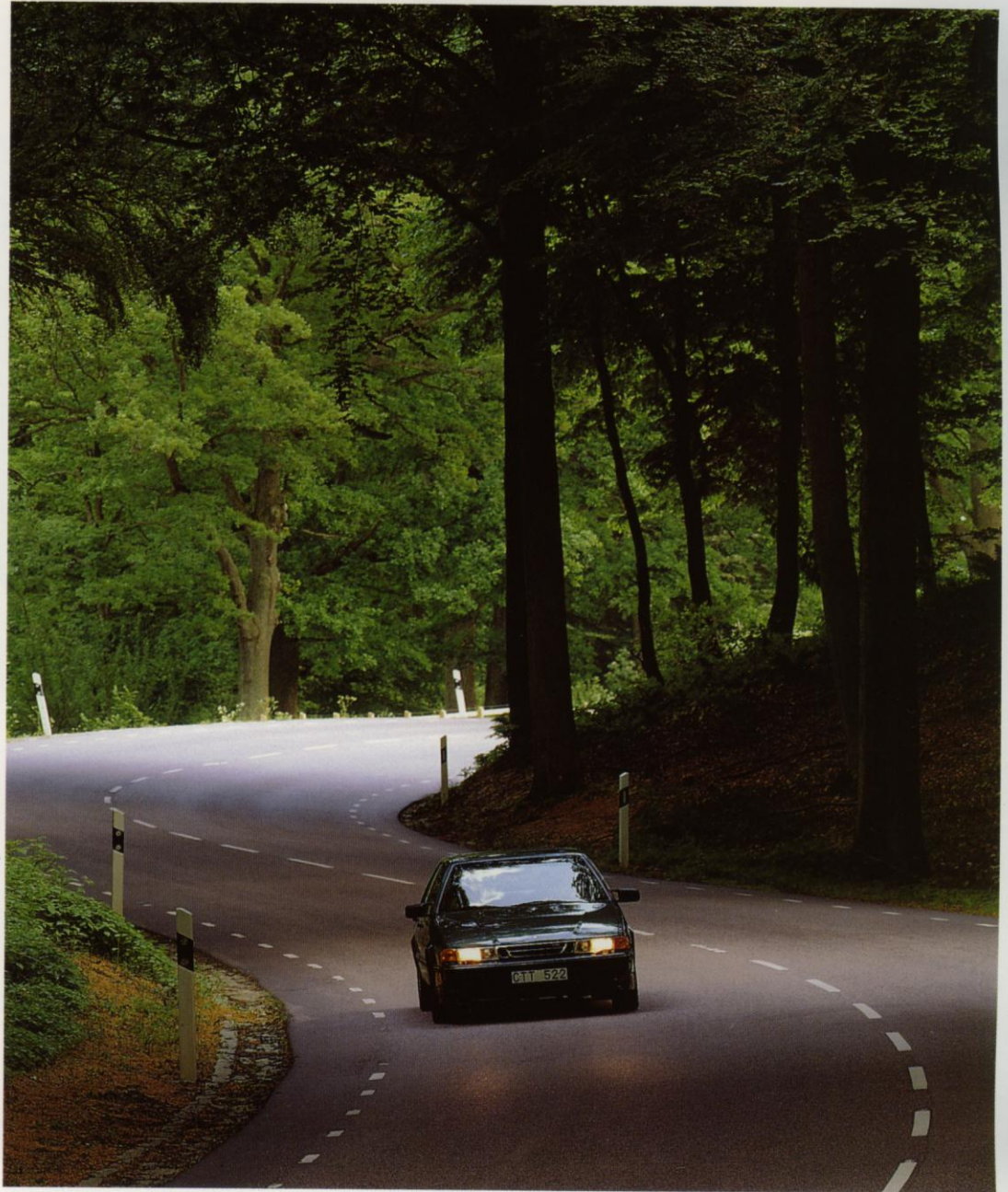

All Saab 9000s have engines with the Trionic management system.

We believe that the more we learn, the better the cars we produce. That's why over the years we've led the world in making greener cars. Our constant quest has led us to develop many solutions that others have adopted. It's also led to technology you'll only find on a Saab.

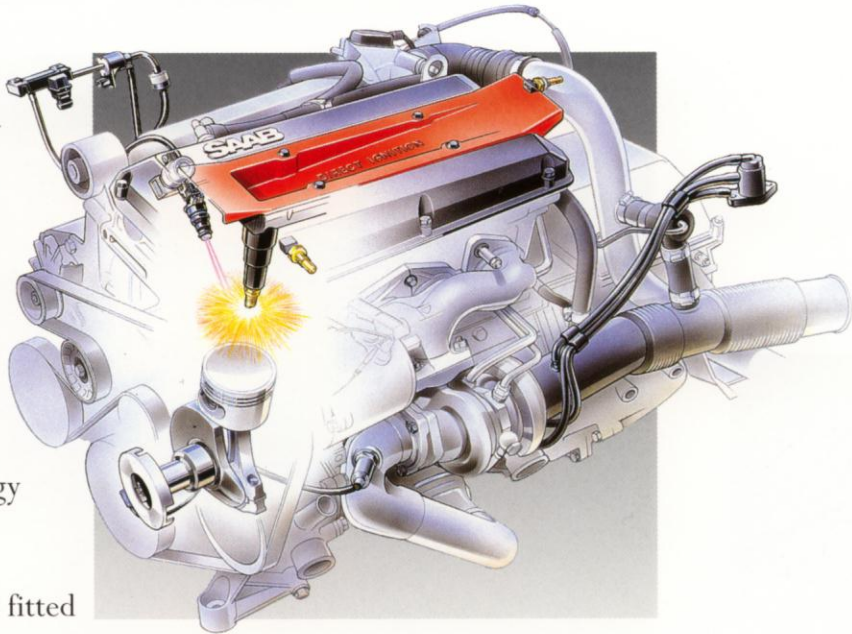

The new Trionic system now fitted to all Saab 9000 engines is a prime example. Unhappy with ordinary engine management systems, we developed our own. It's the only system that controls fuel injection, ignition and boost pressure (on turbo engines) simultaneously. A central microprocessor "learns" and stores information about conditions as you drive. It uses this to constantly adjust the engine's state of tune. No matter what the conditions, the engine always runs at maximum

efficiency with minimum emissions.

In fact, sometimes the exhaust fumes are cleaner than the surrounding air.

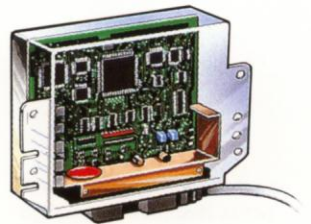

The microprocessor "brain" that controls the Saab Trionic system has greater computing power than the spacecraft used when man took his first step on the moon.



It's reassuring to know your responses are reinforced by our responsibility.

ACTIVE SAFETY.

Active safety is the ability to prevent an accident happening in the first place. Many factors in a Saab 9000 contribute to your active safety. Road-holding, handling, brakes, front-wheel drive, all-round vision, stability and weight distribution.

We've always taken great care to ensure that each one of these plays its appropriate role.

ABS AND TRACTION CONTROL SYSTEM.

The braking system is one of a car's most



Factory-fitted mounting points make installing a child safety seat simple.

important safety features. It has to work perfectly in all conditions. All Saab

9000s have ABS (Anti-Lock Braking System) which prevents the wheels locking and sliding under braking. ABS

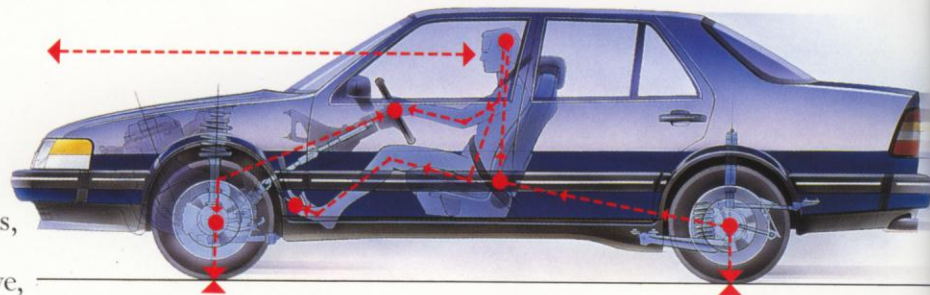

also allows you to steer while braking.

Saab Traction Control System (TCS) improves the driveability of the Saab 9000. It stops the driven wheels spinning on roads where surface friction varies, e.g. patches of ice or puddles of water, and ensures directional stability.

PASSIVE SAFETY.

Passive safety is all about minimising the effects of an accident. In this respect the Saab 9000 is recognised as one of the safest cars in the world.



ABS prevents the wheels locking and sliding under braking.

Sensors trigger the airbag's inflation at the moment of impact.

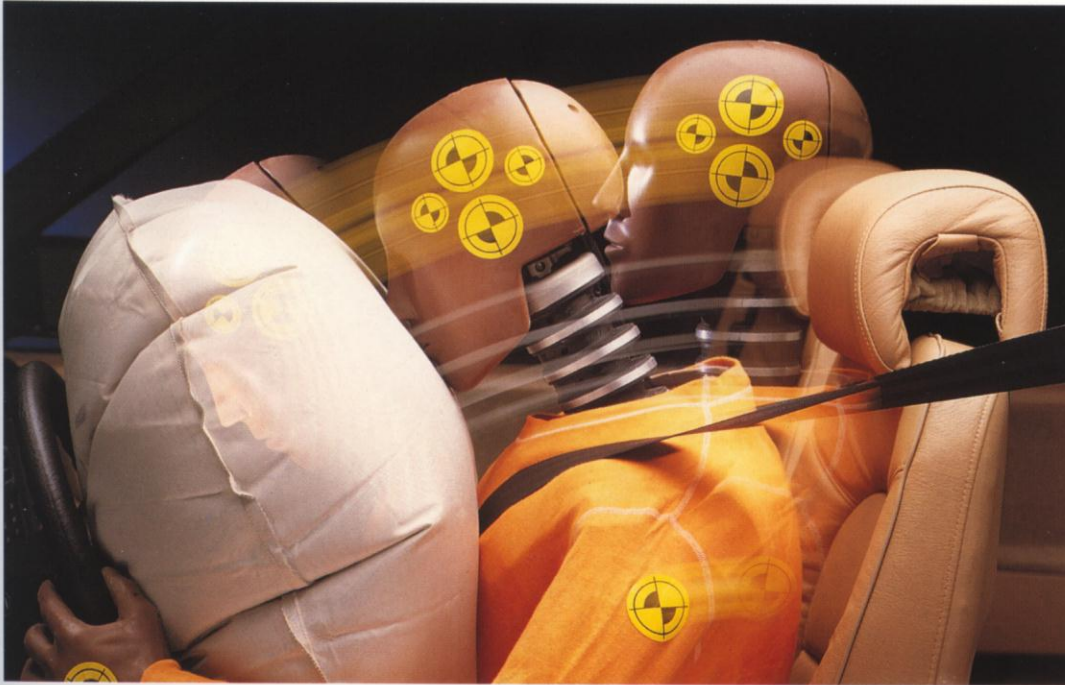
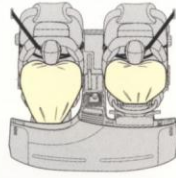

AIRBAG AND SEAT BELTS.

All Saab 9000s are fitted with a standard driver's-side airbag (passenger-side airbag optional). In an accident the bag is inflated in 40 milliseconds. Even before the driver moves forward in his seat, the airbag is there to cushion the impact. Working with the airbag, automatic seat belt tensioners further help restrain front seat occupants. And because child

safety has always been important to Saab, the Saab 9000 has factory-fitted anchorage points for child safety seats, both front (not with passenger airbag) and rear.

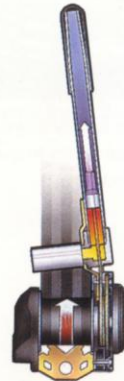

A small charge detonates to tighten the seat belt at the moment of impact.



You set your own standards in driving, but we set them for you in safety.

A Swedish insurance company survey rates the Saab 9000 as one of the

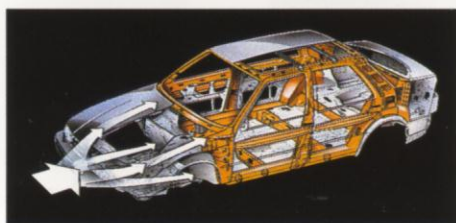
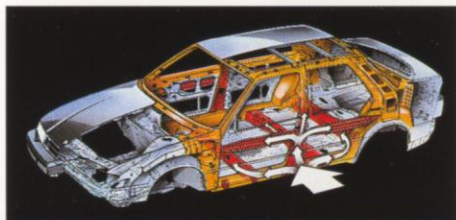

The safety cage is designed to disperse the force of an impact evenly, minimising its effect.

safest cars in the world. When you look at the protection it offers, it's not hard to see why.

The passenger compartment of the car is surrounded by a rigid safety cage that disperses the

force of a collision. This minimises its effect. The doors have impact intrusion beams to protect all occupants from side impacts. Twenty years after we introduced them, other manufacturers are beginning to see their wisdom.

By 1997, the USA will enforce even tougher side-impact protection legislation. All cars must withstand a lateral

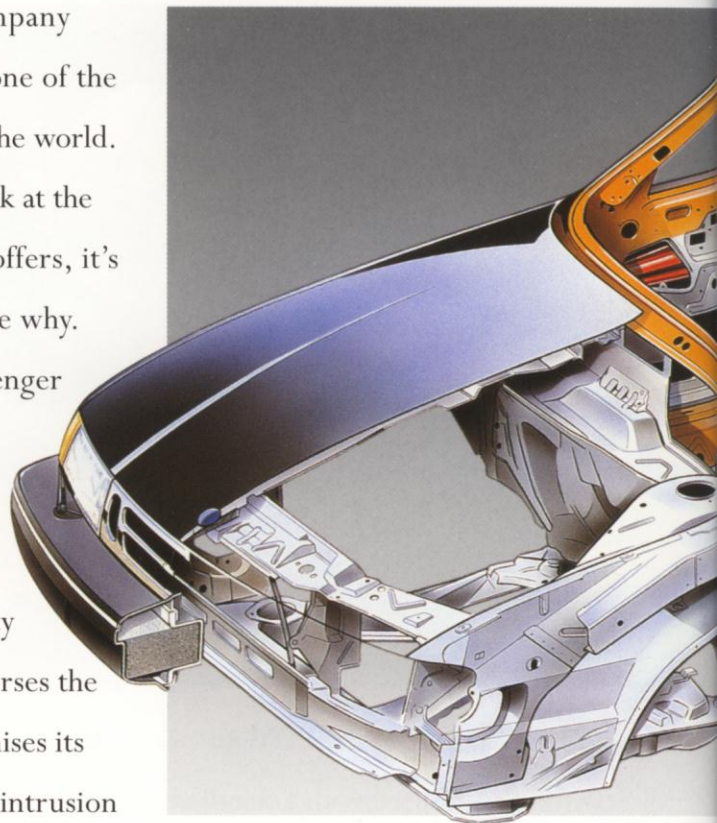

impact from a 1.3-ton block of iron travelling at 54 km/h. The Saab 9000 already meets this requirement.

The front and rear of the car are designed to collapse slowly under heavy impact, absorbing much of the force. Even Saab bumpers are different. They are



The Saab 9000 has been named safest car on the market two times in a row by Folksam, Sweden's largest insurance company.

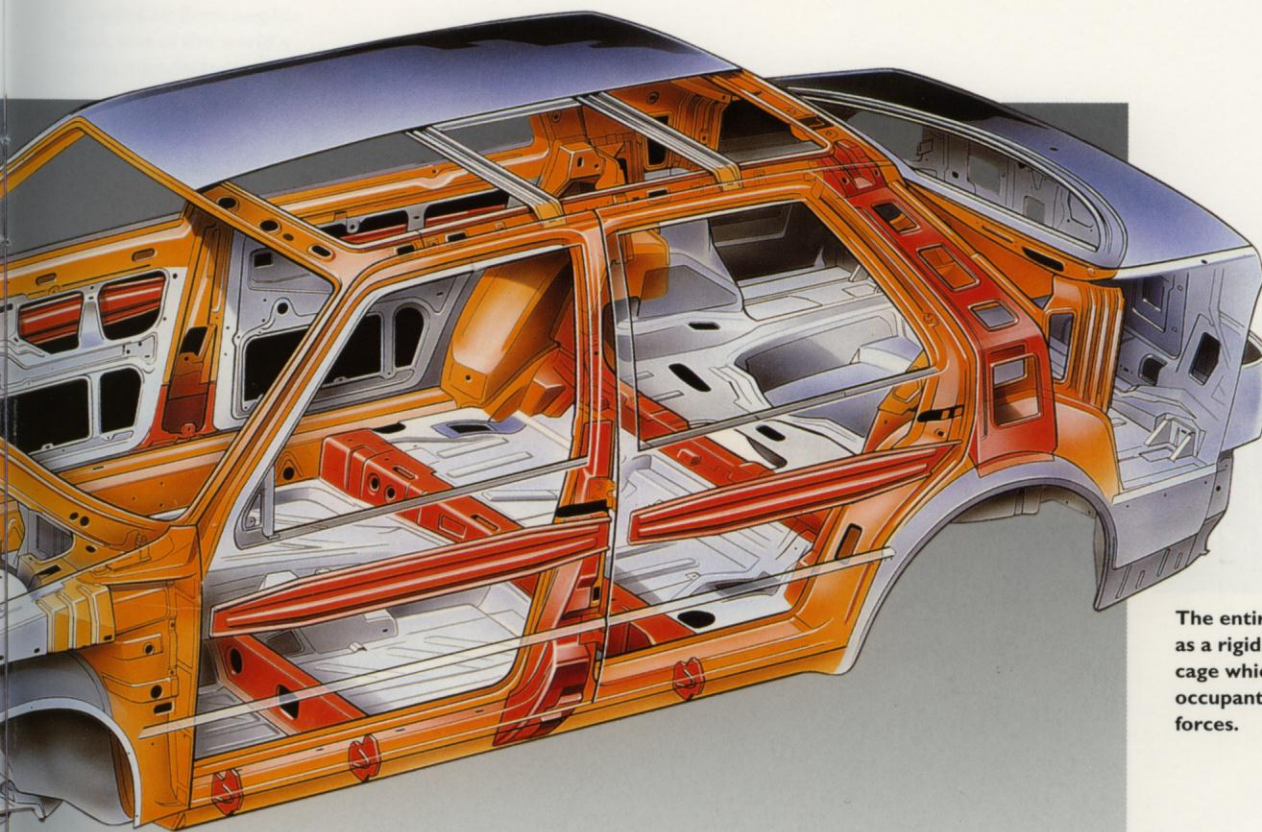

The entire body is designed as a rigid steel safety cage which protects the occupants from outside forces.

designed to deform on impact. But at speeds of up to 8 km/h they spring back into shape.

As you can see, when it comes to your safety, we at Saab leave nothing to chance.



Features of the Saab 9000.

You'd expect a car as unique as the Saab 9000 to have some fairly special features. It won't disappoint you.

LUGGAGE ROOM.

On the Saab 9000 CS the rear seat has a 60/40 split which allows you to carry extra luggage. There's still room for

someone to travel in comfort in the rear.

If you have a truly huge load, the rear seats can be folded flat to give you virtual estate-car capacity. On the Saab 9000 CS this is enhanced by the full-height tailgate.

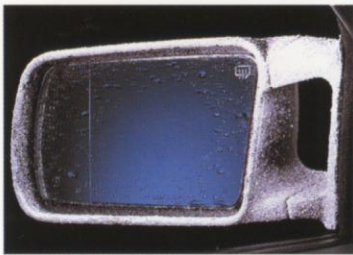

Electrically adjustable heated door mirrors.



The 9000 CS boasts a full-length load platform with seats folded.

Woollen upholstery designed exclusively for the Saab 9000 is supplied by Ermenegildo Zegna, one of the world's leading manufacturers.



The 9000 CD has a special hatch between the rear seats for awkward long loads like carpets or skis.

The removable rear parcel shelf on the Saab 9000 CS provides insulation against road noise. Thanks to its construction the Saab 9000 CS is as quiet as an ordinary saloon.

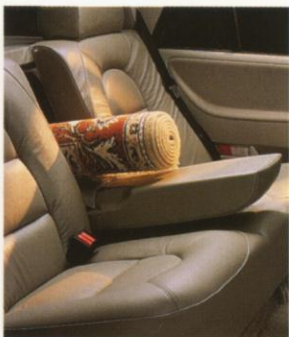

LUXURY ACCOMMODATION.

Saab seats are supremely comfortable. Designed to support you however long your journey. However, they're more than simply functional.

The standard velour upholstery is comfortable winter and summer. The luxury of leather or wool is an option.



Electric windows and central locking are standard equipment on all Saab 9000s.



Options and accessories.

Four-season comfort — with Automatic Climate Control (ACC).



Four-speed automatic transmission with lock-up for better fuel efficiency.

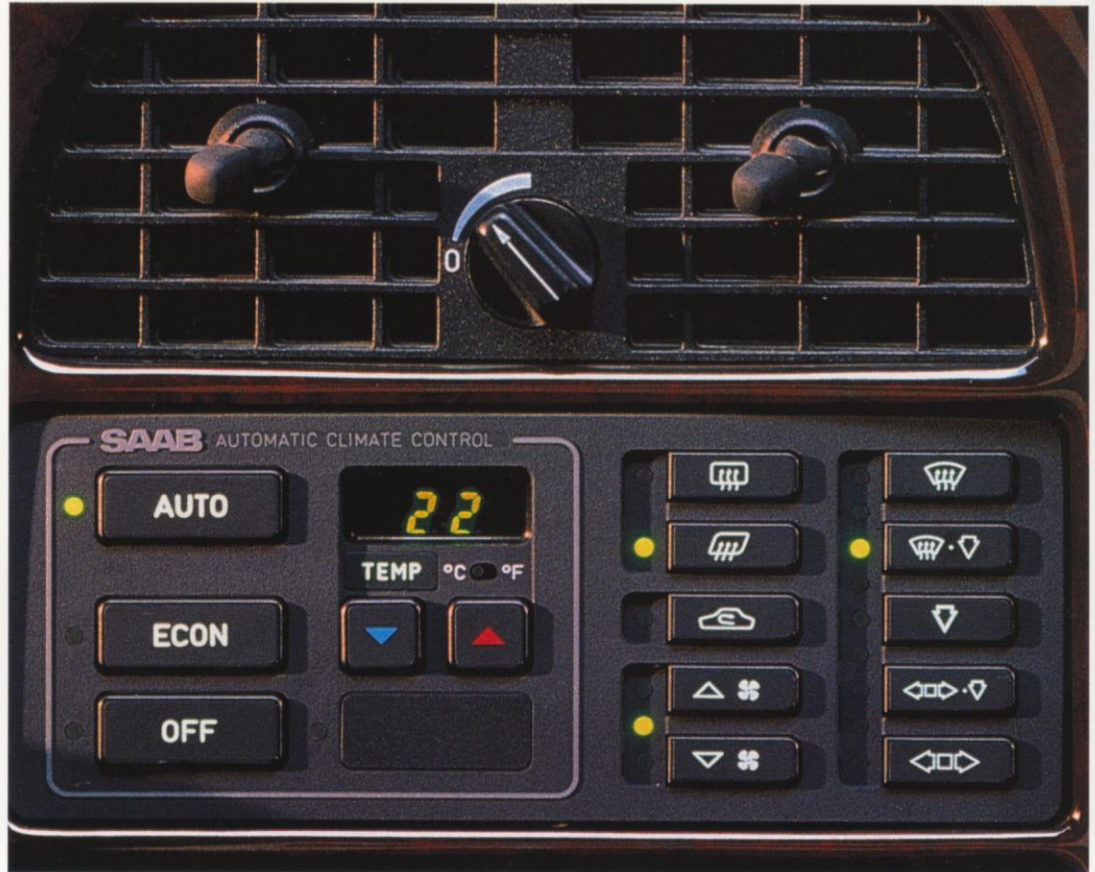

The Saab 9000 is one of the best-equipped cars you can find. However, we know that Saab drivers like to add their own individual touches. That's why we have a range of accessories made to our own high standards for you to choose from.



The Saab Car Computer (SCC) seen here in the optional walnut facia.

A touch of class: leather gear lever knob and gaiter



The Saab Car Computer (SCC) offers you important information about your car's operation, including average speed, distance to destination and speed limit warning.

For year-round comfort, you may wish to consider Automatic Climate Control (ACC) that lets you select and maintain the interior temperature you desire. The system is totally CFC-free and uses a new Saab-pioneered coolant, R134a. You can enhance the interior comfort of your Saab in other luxurious



Sit back and relax with the folding centre armrest.

ways. A leather gear lever knob and gaiter provide additional elegance ... and a classic touch. The centre armrest is available to

provide extra comfort, folding down to help you relax on long trips.

Saab textile carpet mats protect your car's interior from wear and add comfort underfoot.

And outside, you can add a personal styling touch with a selection



The five-spoke light alloy wheel is just one of many available styles.

from our fine choice of alloy wheels.

Sporty, stylish and lightweight, they're the perfect finishing touch for the beauty of your Saab 9000.



Complement your car's interior with genuine Saab textile carpet mats.



Technical specifications Saab 9000, 1994.

Engine

Transverse, four-cylinder, in-line engine. Cast iron cylinder block. Light alloy, cross-flow cylinder head. Dome-shaped combustion chambers with centrally placed spark plugs. Double overhead, chain-driven camshafts. Hydraulic, maintenance-free valve depressors. Four valves per cylinder. Two balancer shafts equipped with eccentrically mounted balance weights.

Engine management and emission control

Saab Trionic system that monitors and controls fuel injection, ignition (Saab DI) and turbo boost pressure. Three-way, metallic catalytic converter and Lambda-sensor.

Turbo charging*

Turbocharger with watercooled bearing housing and integrated wastegate (boost pressure control valve). Intercooler (not on 2.0-litre Light Pressure Turbo).

*) Turbo and Light Pressure Turbo (Ecopower) engines only.

Cooling system

Electric motor-driven, thermostatically controlled radiator fan. Engine oil cooler on the Turbo and Light Pressure Turbo engines.

Fuel tank capacity

66 litres.

Electrical system

Alternator: 1070 W 80 A.

Battery: 12 V 60 Ah (maintenance-free).

Transmission

Front wheel drive with full synchromesh, five-speed manual gearbox or four-speed automatic transmission with direct mechanical lock-up in top gear. Compact, transversely mounted gearbox integrated with the engine and differential.

Steering

Power-assisted rack and pinion steering. Impact-collapsible steering column.

Turning circle: Kerb to kerb 10.9 m.

Brakes

Anti-lock braking system (ABS). Power-assisted disc brakes all round, ventilated in front. Self-adjusting, single piston system with floating brake caliper. Asbestos free pads. Mechanical action of hand brake on rear wheel discs.

	TURBO ENGINE 2.3-LITRE (AERO)	TURBO ENGINE 2.3-LITRE	TURBO ENGINE 2.0-LITRE	LIGHT PRESSURE TURBO (ECOPOWER) ENGINE 2.3-LITRE
Displacement	2.290 dm ³	2.290 dm ³	1.985 dm ³	2.290 dm ³
Bore/stroke	90/90 mm	90/90 mm	90/78 mm	90/90 mm
EEC rating	225 hp (165 kW) at 5500 rpm	200 hp (147 kW) at 5500 rpm	185 hp (136 kW) at 5500 rpm	170 hp (125 kW) at 5700 rpm
EEC peak torque	34.9 kpm (342 Nm) at 1800 rpm	32.9 kpm (323 Nm) at 1800 rpm; aut. 30.0 kpm (294 Nm) at 1800 rpm	28.8 kpm (283 Nm) at 2100 rpm	26.5 kpm (260 Nm) at 3200 rpm
Max. boost pressure	1.08 bar	1.00 bar; aut. 0.81 bar	1.05 bar	0.40 bar
Compression ratio	9.25:1	9.25:1	9.2:1	9.25:1
Recommended octane rating, unleaded only	98 RON (minimum 91)	95 RON (minimum 91)	95 RON (minimum 91)	95 RON (minimum 91)
Top speed	240 km/h	235 km/h; aut. 235 km/h	230 km/h	220 km/h; aut. 220 km/h
Acceleration to 100 km/h	6.9 sec.	7.5 sec.; aut. 8.5 sec	8.3 sec.	8.5 sec.; aut. 9.5 sec
Overtaking acceleration	60–100 km/h in fourth gear 6.5 sec.; 80–120 km/h in fifth gear 8.9 sec.	60–100 km/h in fourth gear 6.6 sec.; 80–120 km/h in fifth gear 9.1 sec.	60–100 km/h in fourth gear 7.5 sec.; 80–120 km/h in fifth gear 10.0 sec.	60–100 km/h in fourth gear 10.0 sec.; 80–120 km/h in fifth gear 14.0 sec.

Saab 9000 CS

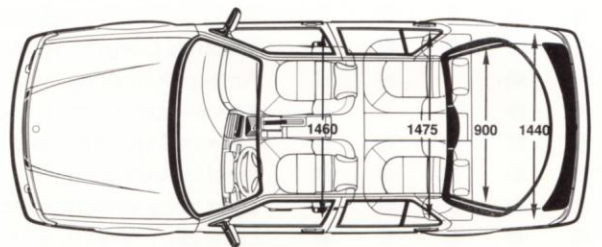
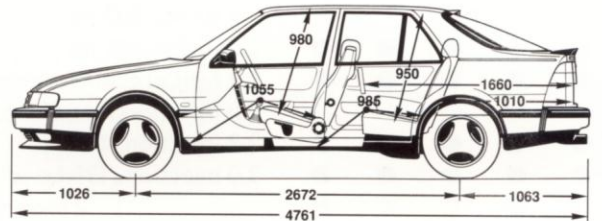
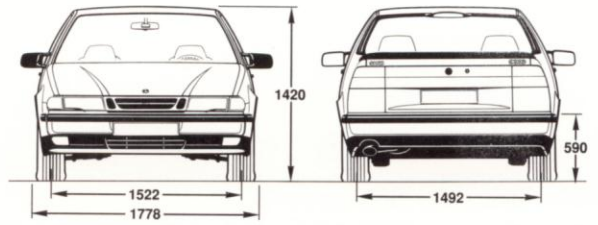

9000 CD models: Length 1110 mm. Long articles can be placed through the armrest opening in the back seat. Volume 562 dm³ VDA; 503 dm³ SAE.

Weights

Weight distribution: 60% front, 40% rear.
 Max trailer load: 9000 CS models 1800 kg, 9000 CD models 1600 kg.
 Max roof load: 100 kg.
 Kerb weight: 9000 CS models about 1365–1500 kg, 9000 CD models about 1345–1455 kg.
 Max total weight: 1960 kg.

Suspension

Front: McPherson spring struts, chassis anti-roll bar, twin-pipe gas shock-absorbers of low-pressure type and integrated wheel bearings.
 Rear: Straight, unsplit axle with coil springs, gas shock-absorbers, anti-roll bar, two trailing and two leading arms and Panhard rod.

Luggage compartment

9000 CS models: Completely collapsible back seat or 40 or 60% foldable. Removable parcel shelf. Length with back seat in position 1010 mm. Length with back seat folded down 1660 mm. Volume with back seat in position 487 dm³ VDA; 448 dm³ SAE. Volume with entire back seat folded down 1397 dm³ VDA; 1183 dm³ SAE.

Saab 9000 CD

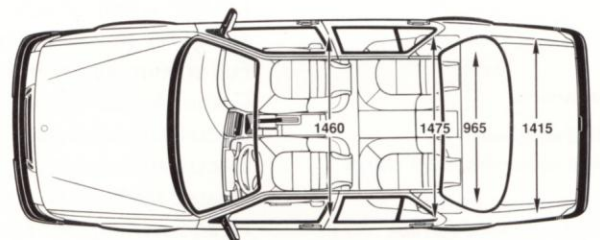
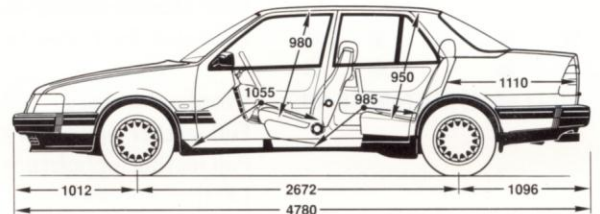
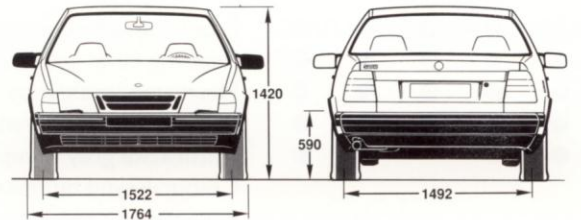

LIGHT PRESSURE TURBO (ECOPOWER) ENGINE 2.0-LITRE	INJECTION ENGINE 2.3-LITRE	INJECTION ENGINE 2.0-LITRE
1.985 dm ³	2.290 dm ³	1.985 dm ³
90/78 mm	90/90 mm	90/78 mm
150 hp (110 kW) at 5500 rpm	147 hp (108 kW) at 5600 rpm	130 hp (96 kW) at 5500 rpm
21.4 kpm (210 Nm) at 2500 rpm	20.9 kpm (205 Nm) at 3800 rpm	18.0 kpm (177 Nm) at 4300 rpm
0.59 bar		
8.8:1	10.5:1	10.1:1
95 RON (minimum 91)	95 RON (minimum 91)	95 RON (minimum 91)
210 km/h; aut. 210 km/h	210 km/h; aut. 205 km/h	200 km/h
10.0 sec.; aut. 11.0 sec	10.0 sec.; aut. 12.0 sec	11.5 sec.
60–100 km/h in fourth gear 9.0 sec.; 80–120 km/h in fifth gear 12.0 sec.	60–100 km/h in fourth gear 10.0 sec.; 80–120 km/h in fifth gear 15.0 sec.	60–100 km/h in fourth gear 12.5 sec.; 80–120 km/h in fifth gear 20.0 sec.

Equipment Saab 9000, 1994.

		Aero	CSE	CS	Griffin	CDE	CD
ENGINES	2.3 turbo, 225 hp	◆ ¹					
	2.3 turbo, 200 hp	◆ ²	◆	◆	◆	◆	◆
	2.0 turbo, 185 hp		◆ ¹	◆ ¹		◆ ¹	◆ ¹
	2.3 light pressure turbo (Ecopower), 170 hp		◆	◆		◆	◆
	2.0 light pressure turbo (Ecopower), 150 hp		◆	◆		◆	◆
	2.3 injection, 147 hp		◆	◆		◆	◆
	2.0 injection, 130 hp		◆ ¹	◆ ¹		◆ ¹	◆ ¹
FUNCTION AND SAFETY	Manual 5-speed gearbox	●	●	●	●	●	●
	Automatic 4-speed transmission (not 2.0i and 2.0 turbo)	○	○	○	○	○	○
	Traction Control System, TCS	○					
	Anti-lock braking system, ABS	●	●	●	●	●	●
	Power assisted rack and pinion steering	●	●	●	●	●	●
	Lowered sport chassis	●					
	Steel wheels with wheel covers, 6x15"			●			●
	Light alloy wheels, 6x15"		●	○	●	●	○
	Light alloy wheels, 6.5x16"	●					
	Side impact protection bars and structure	●	●	●	●	●	●
	Impact resistant bumpers (8 km/h)	●	●	●	●	●	●
	Driver's airbag	●	●	●	●	●	●
	Passenger's airbag	○	○	○	○	○	○
	Automatic front seatbelt tensioners	●	●	●	●	●	●
Child seat anchorage points, both front (not on cars with passenger side airbag) and rear	●	●	●	●	●	●	
EXTERIOR AND LIGHTING	Front fog lamps	●	●	○	●	●	○
	Rear fog lamp	●	●	●	●	●	●
	Headlamp wash/wipe	●	●	●	●	●	●
	Rear window wash/wipe	○	○	○			
	Anthracite grey bumpers			●	●	●	●
	Colour-keyed bumpers	●	●				
	Rear spoiler, black (turbo only)		●	●			
	Rear spoiler, colour-keyed	●					
	Provision for trailer hitch	●	●	●	●	●	●
INTERIOR AND SEATS	Wool upholstery	○	○	○	●	○	○
	Full leather upholstery, sports trim	●					
	Full leather upholstery				○		
	Leather upholstery		○	○		○	○
	Piqué upholstery		●	●		●	●
	Leather trimmed steering wheel and leather gear lever knob and gaiter (manual only)	●	●	○	●	●	○
	Full walnut veneer interior				●		
	Colour-keyed instrument panel	●	●	●	●	●	●
	Electrically adjustable front seats, memory on driver's side	●	○	○	●	○	○
	Electrically adjustable driver's seat with memory		○	○		○	○
	Heated front seats, adjustable heating	●	●	●	●	●	●
Head restraints for four seats, provision for a fifth	●	●	●	●	●	●	

◆ Engine variants

● Standard equipment

○ Optional equipment, extra charge

1) Only with manual gearbox

2) Only with automatic gearbox

		Aero	CSE	CS	Griffin	CDE	CD
COMFORT AND PRACTICAL FEATURES	Automatic Climate Control (ACC), CFC-free	●	●	○	●	●	○
	Air conditioning (AC), CFC-free			○			○
	Ventilation air filter	●	●	●	●	●	●
	Rear side window demister ducts (only cars with ACC)	●	●	●	●	●	●
	Electrically operated glass sunroof, tilt/sliding	○	○	○	○	○	○
	Electrically operated windows	●	●	●	●	●	●
	Electrically operated and heated exterior mirrors	●	●	●	●	●	●
	Central locking, operated at both front doors	●	●	●	●	●	●
	Tinted heat absorbing glass	●	●	●	●	●	●
	Height adjustable front seatbelts	●	●	●	●	●	●
	Driver and passenger vanity mirrors	●	●	●	●	●	●
	Illuminated vanity mirrors	●	●		●	●	
	Interior light with fade delay	●	●	●	●	●	●
	Front roof console with spotlight	●	●	●	●	●	●
	Rear seat reading lamps	●	●	●	●	●	●
	Storage compartments, front and rear doors	●	●	●	●	●	●
	Storage pockets at seat backs	●	●	●	●	●	●
	Grab handles, all outer seating positions	●	●	●	●	●	●
	Internal trunk release	●	●	●	●	●	●
	Folding down rear seat with split 60/40	●	●	●			
	Ski hatch (load through, middle rear armrest)				●	●	●
	Illuminated luggage compartment	●	●	●	●	●	●
	Closing handle inside trunk	●	●	●	●	●	●
INSTRUMENTATION AND DRIVER ENVIRONMENT	Saab Car Computer (SCC)	●	○	○	●	○	○
	EDU instrument (outside temp, fuel consumption etc)	●	●	●	●	●	●
	Pictogram (open door/failed light indicator etc)	●	●	●	●	●	●
	Tachometer	●	●	●	●	●	●
	Headlamp elevation control on facia	●	●	●	●	●	●
	Cruise control	●	●	○	●	●	○
AUDIO EQUIPMENT	Saab Audio System (incl speakers/power antenna)	○	○	○	○	○	○
	CD-autoplayer (only in combination with Saab Audio System)	○	○	○	○	○	○
	Power antenna	●	●	○	●	●	○
	Front speakers	●	●	○	●	●	○
	Rear speakers	●	●	○	●	●	○

Upholstery.

Wool



Rocky Black (K64)

Leather



Rocky Black (K33/K35)

Piqué



Rocky Black (K44)



Dover (H33/H35)



Angora (H44)



Pamir (J33)



Alpacka (J44)



Arizona (G33)

AVAILABLE TRIM COMBINATIONS.

	Arizona	Dover Angora	Pamir Alpacka	Rocky Black
Black	○	○	×	○
Embassy blue	○	×	○	○
Cirrus white	○	○	○	×
Imola red	○	○	○	×
Le Mans blue	○	×	○	○
Platana grey	–	×	○	○
Ruby red	○	○	○	×
Scarabee green	×	○	○	○
Citrine beige	–	○	×	○
Aubergine	–	○	×	○
Eucalyptus green	○	○	×	×

× = our recommended combinations

○ = available alternatives

Check with your Saab dealer for the available trim combination.

Following traditional motor-industry practice, the leather upholstery refers to seating surfaces only.

Colours.



Black (170)



Cirrus white (153)



Imola red (240)

Solids



Embassy blue (198)



Citrine beige (227)



Platana grey (228)



Ruby red (242)

Metallics



Scarabee green (230)



Eucalyptus green (235)



Aubergine (241)



Le Mans blue (229)

The colours shown here should be taken as a guide only. Due to printing processes they may not always be an exact match to the actual paint colour.



All particulars and illustrations in this brochure are based on the specifications of the cars valid at the date of the final editing of the publication (June 1993). The model range, technical specifications and equipment may vary from one market to the next and may be altered without prior notice. For further information, please consult your Saab dealer. Note that some of the pictures in the brochure may show cars fitted with optional extra equipment.



SAAB

Saab Automobile AB
Trollhättan, Sweden

Int Eng Art. No. 261123 Printed in Sweden on chlorine-free paper. © Copyright, Saab Automobile AB, 1993.

